

Proposal Basic Information	
Proposal File No.	MNP/IBP/0029/W06/2022
Owner Name	SMT. SAMPAL TALUKDAR
Khata No	97/3
Plot No	NA
Village Name	Patharchptti
Use	Residential
SubUse	Bungalow/ Dwelling / Non Apartment

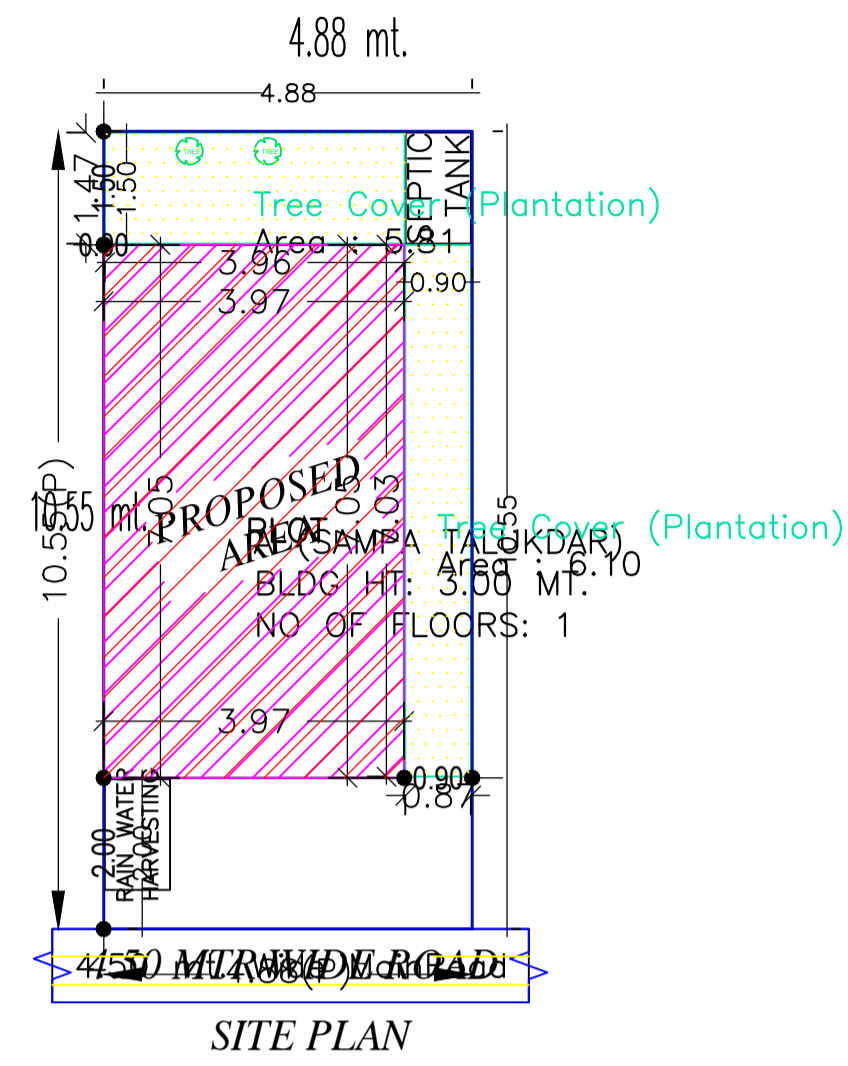

SITE PLAN

AREA STATEMENT	VERSION NO. : 1.0.62
MADHUPUR NAGAR	VERSION DATE: 16/10/2020
PARISHAD	
PROJECT DETAIL:	
Region: JHARKHAND URBAN LOCAL BODIES	Plot Use: Residential
District: DEOGHAR	Plot SubUse: Bungalow/ Dwelling / Non Apartment
Authority: MADHUPUR NAGAR PARISHAD	PlotNearby/ReligiousStructure: NA
Inward No: MNP/IBP/0029/W06/2022	Plot/SubPlot No: NA
Application Type: General Proposal	North: Plot No. - VENDORS LAND
Project Type: Building Permission	South: Plot No. - VENDORS LAND
Nature of Development: New	East: Plot No. - VENDORS LAND
Location of Development Area: Old Area	West: Road Width - 4.50
AREA DETAILS:	
AREA OF PLOT (Minimum)	(A) 51.43
NET AREA OF PLOT(Gross Plot Area - Deduction from Gross Plot area)	(A-Deductions) 51.43
Deduction for Balance Plot Area(from Gross Plot Area)	
Common Plot	11.92
Total	11.92
BALANCE AREA OF PLOT(Net Plot Area - Recreational/Amenity space)	(A-Deductions) 39.52
PLOT AREA FOR COVERAGE(Net Plot Area)	(A-Deductions) 51.43
Plot Area for FAR (Net Plot Area + RoadWidening Area)	(A-Deductions) 51.43
COVERAGE CHECK	
Permissible Coverage area ( 70.00 % )	36.00
Proposed Coverage Area ( 54.48 % )	28.02
Total Prop. Coverage Area ( 54.48 % )	28.02
Balance coverage area ( 15.52 % )	7.98
FAR CHECK	
Perm. FAR Area ( 1.50 )	77.15
Total Perm. FAR area	77.15
Residential FAR	28.02
Proposed FAR Area	28.02
Total Proposed FAR Area	28.02
Consumed FAR (Factor)	0.54
Balance FAR Area	49.13
BUILT UP AREA CHECK	
Total Proposed BuiltUp Area	28.02
ARCHITECT (Regd)	RAJKISHOR KUMAR
ENGINEER (Regd)	
SUPERVISOR (Regd)	
OWNER (Regd)	SMT. SAMPAL TALUKDAR
DEVELOPMENT AUTHORITY	LOCAL BODY

Buildingwise Floor FAR Details

Floor Name	Building Name A (SAMPAL TALUKDAR)		Total	
	Proposed Built Up Area (Sq.mt.)	Proposed FAR Area (Sq.mt.)	Total Proposed Built Up Area (Sq.mt.)	Total FAR Area (Sq.mt.)
Ground Floor	28.02	28.02	28.02	28.02
Terrace Floor	0.00	0.00	0.00	0.00
Total :	28.02	28.02	28.02	28.02

Building USE/SUBUSE Details

Building Name	Building Use	Building SubUse	Building Structure
A (SAMPAL TALUKDAR)	Residential	Bungalow/ Dwelling / Non Apartment	Non-Highrise

FAR & Tenement Details (Table 4c-1)

Building	No. of Same Bldg	Total Built Up Area (Sq.mt.)	Proposed FAR Area (Sq.mt.) Resi.	Total FAR Area (Sq.mt.)	Total Consumed Additional FAR Area (Sq.mt.)	Tnmt (No.)
A (SAMPAL TALUKDAR)	1	28.02	28.02	28.02	28.02	01
Grand Total :	1	28.02	28.02	28.02	28.02	01

COLOR INDEX	
PLOT BOUNDARY	
ABUTTING ROAD	
PROPOSED CONSTRUCTION	
COMMON PLOT	
ROAD WIDENING AREA	
EXISTING (To be retained)	
EXISTING (To be demolished)	

LTP NAME AND SIGNATURE	STRUCTURAL ENG'S NAME AND SIGNATURE	BUILDER NAME AND SIGNATURE	DIGITAL SIGNATURE
RAJKISHOR KUMAR MNP/ENG/0003/2018			

DATE	24-06-2022
SHEET NO.	2
Proposal Basic Information	
Proposal File No.	MNP/BI/0029/W06/2022
Owner Name	SMT. SAMPA TALUKDAR
Khata No	97/3
Plot No	NA
Village Name	Patharchptti
Use	Residential
SubUse	Bungalow/ Dwelling / Non Apartment

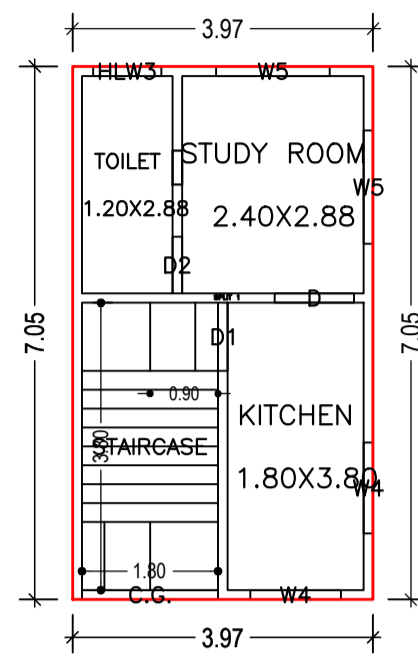

GROUND FLOOR PLAN  
(Proposed)  
(SCALE 1:100)

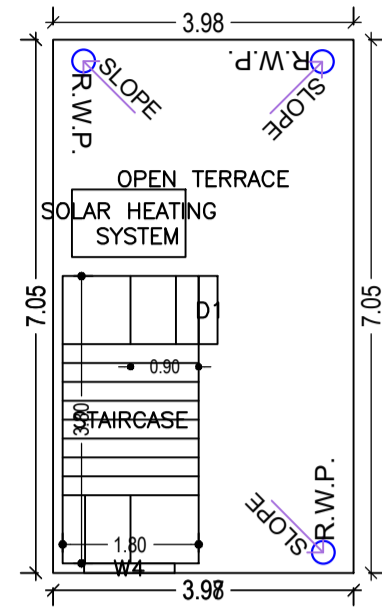

TERRACE FLOOR PLAN  
(SCALE 1:100)

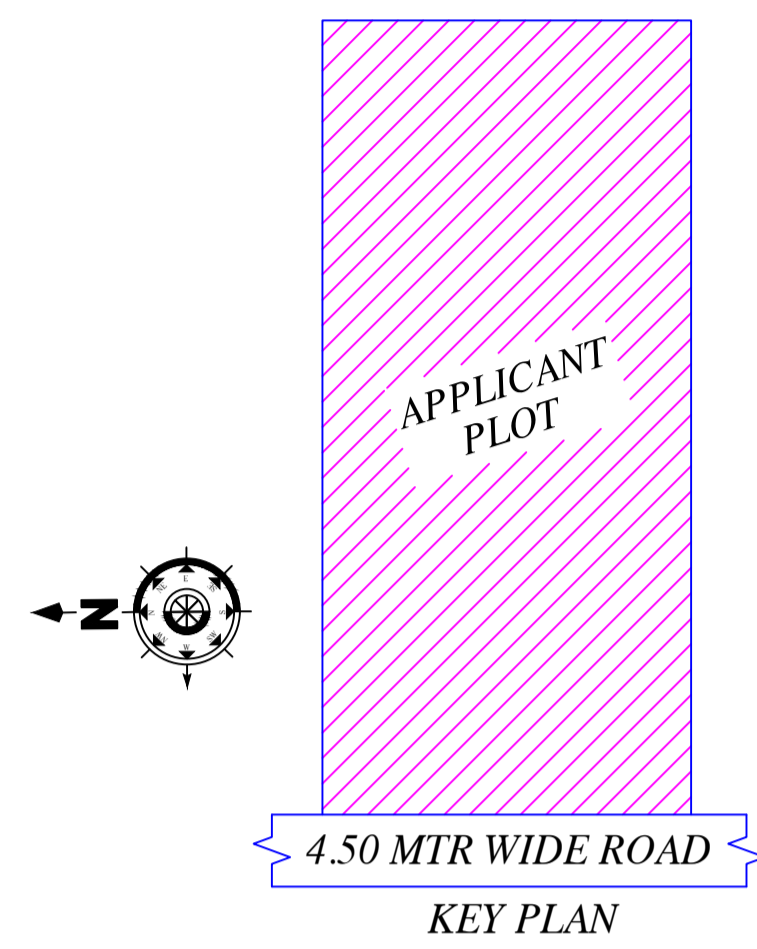

UnitBUA Table for Building :A (SAMPA TALUKDAR)

FLOOR	Name	UnitBUA Type	UnitBUA Area	Carpet Area	No. of Rooms	No. of Tenement
GROUND FLOOR PLAN	SPLIT 1	FLAT	18.49	18.43	3	1
Total:	-	-	18.49	18.43	3	1

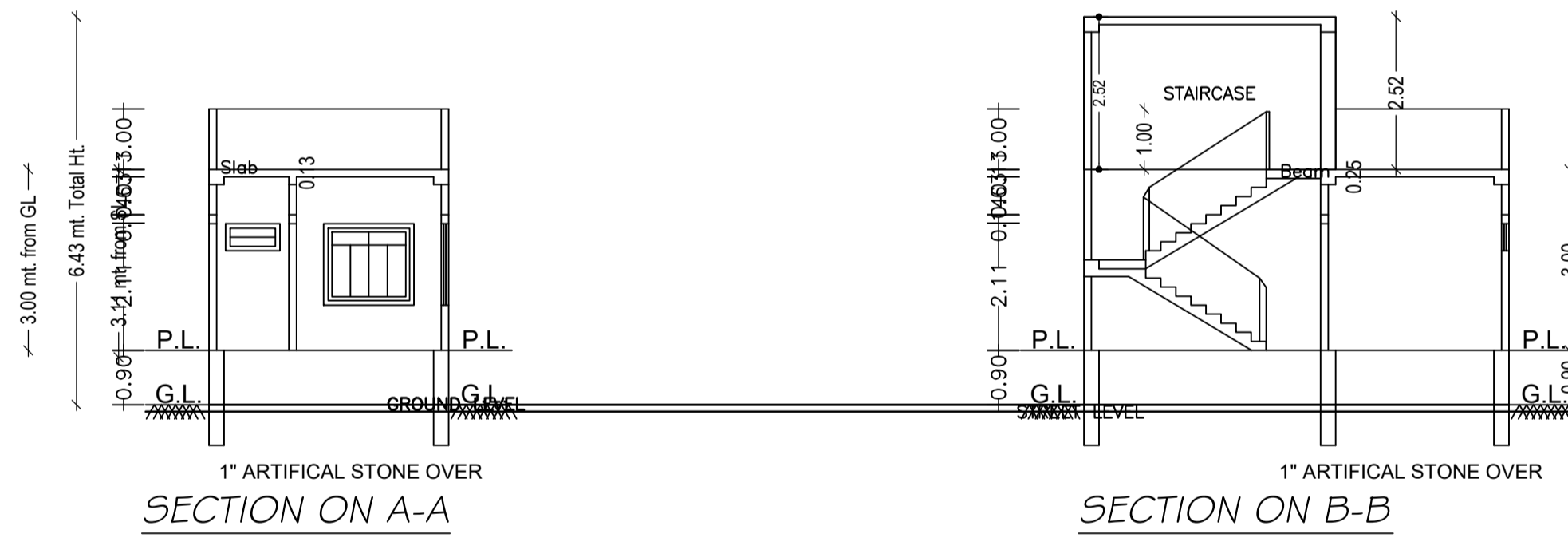

SCHEDULE OF DOOR:

BUILDING NAME	NAME	LENGTH	HEIGHT	NOS
A (SAMPA TALUKDAR)	D2	0.75	2.10	01
A (SAMPA TALUKDAR)	D1	0.90	2.10	01
A (SAMPA TALUKDAR)	D	1.05	2.10	01

SCHEDULE OF WINDOW/VENTILATION:

BUILDING NAME	NAME	LENGTH	HEIGHT	NOS
A (SAMPA TALUKDAR)	HLW3	0.90	0.60	01
A (SAMPA TALUKDAR)	W4	1.20	1.35	03
A (SAMPA TALUKDAR)	W5	1.50	1.35	02

Building :A (SAMPA TALUKDAR)

Floor Name	Total Built Up Area (Sq.mt.)	Proposed FAR Area (Sq.mt.) Resi:	Total FAR Area (Sq.mt.)	Total Consumed Additional FAR Area (Sq.mt.)	Tnmt (No.)
Ground Floor	28.02	28.02	28.02	28.02	01
Terrace Floor	0.00	0.00	0.00	0.00	00
Total	28.02	28.02	28.02	28.02	01
Total Number of Same Buildings	1				
Total :	28.02	28.02	28.02	28.02	01

LTP NAME AND SIGNATURE	STRUCTURAL ENG'S NAME AND SIGNATURE	BUILDER NAME AND SIGNATURE	DIGITAL SIGNATURE
RAJKISHOR KUMAR MNP/ENG/0003/2018			

Proposal Basic Information	
Proposal File No.	MNP/BI/0029/W06/2022
Owner Name	SMT. SAMPA TALUKDAR
Khata No	97/3
Plot No	NA
Village Name	Patharchptti
Use	Residential
SubUse	Bungalow/ Dwelling / Non Apartment

This is certify that the structure design is in accordance with the latest I-S code(I-S 875,I-S456-2002, I-S 1893-2000) for design & loading conditions (Sessmic/wind/dead/live) and other all parameters are taken in account for safetyof the structure.

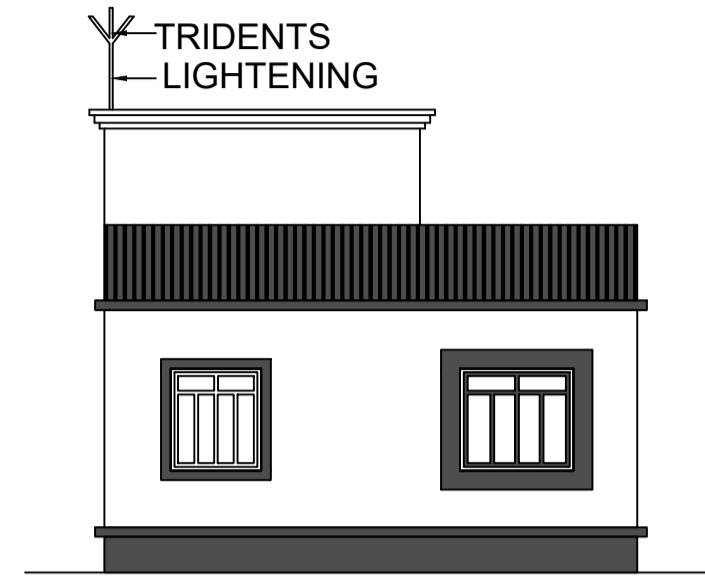

R.H.S. ELEVATION

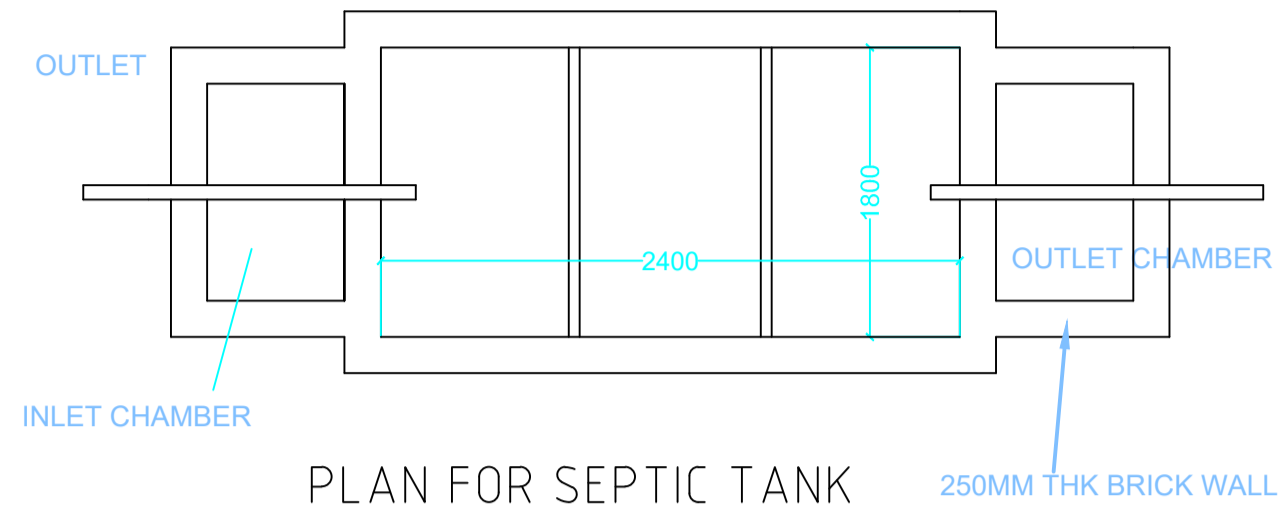

PLAN FOR SEPTIC TANK

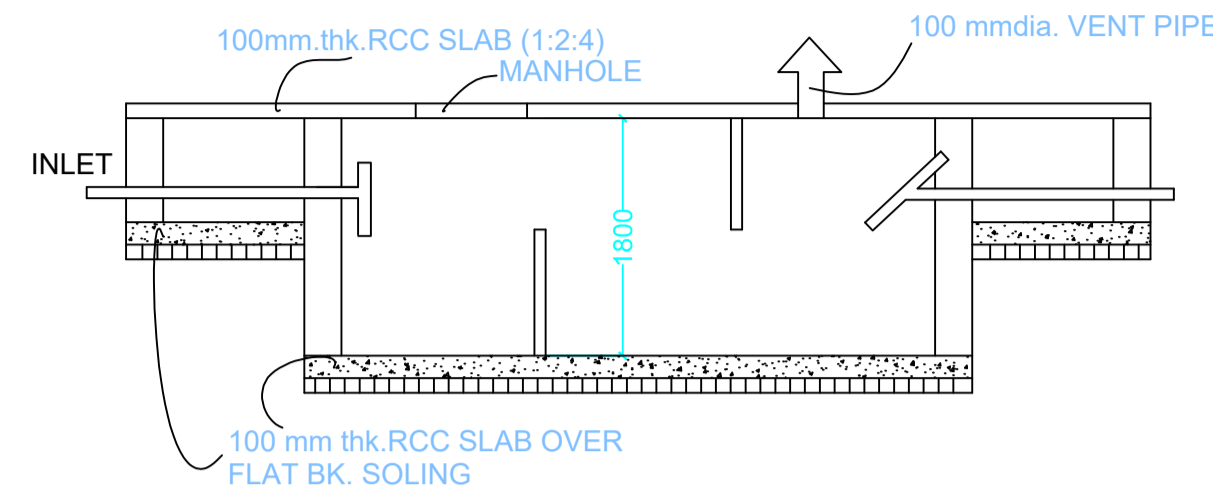

SECTION SCALE 1:50 SEPTIC TANK DETAILS

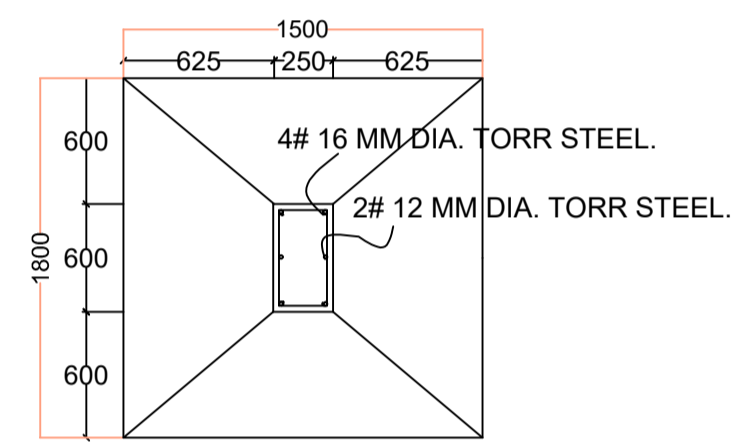

PLAN

FOUNDATION DETAILS (ISOLATED R.C.C FOOTING)

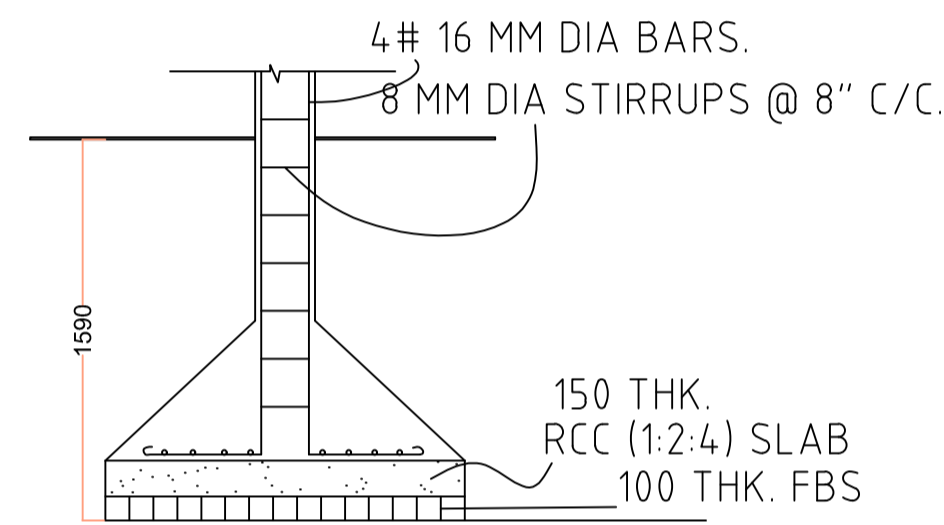

SECTION

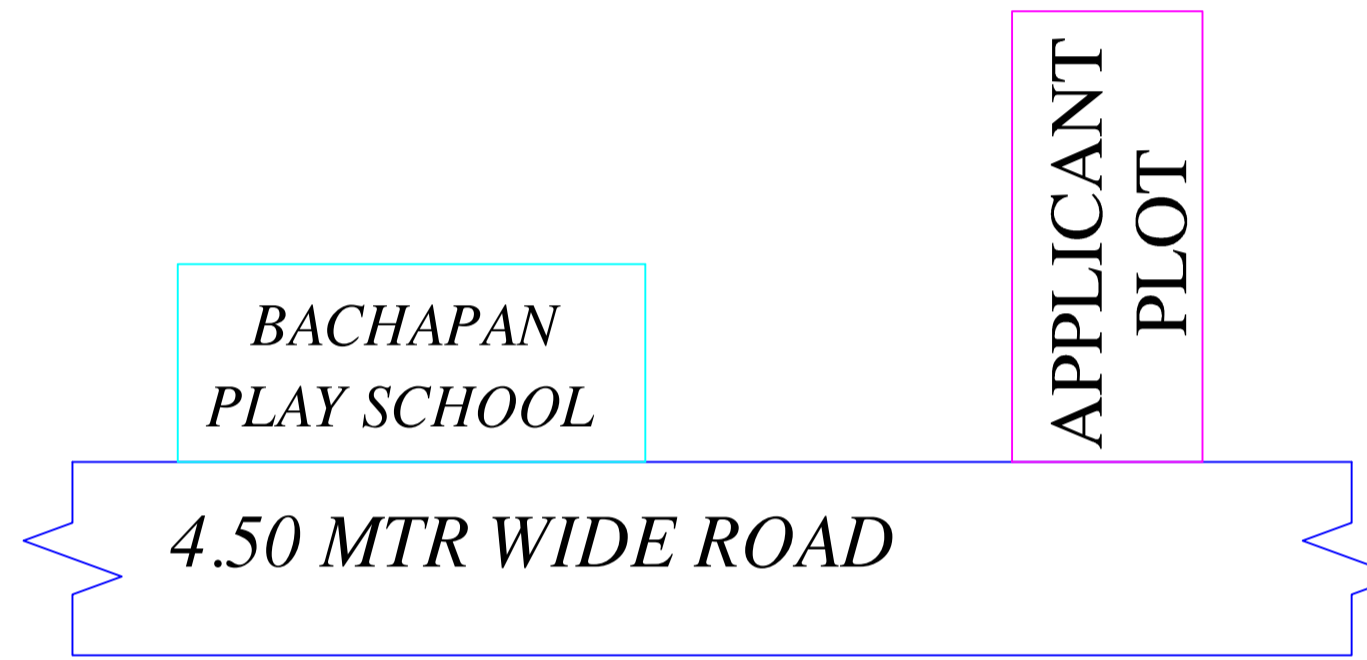

LOCATION MAP

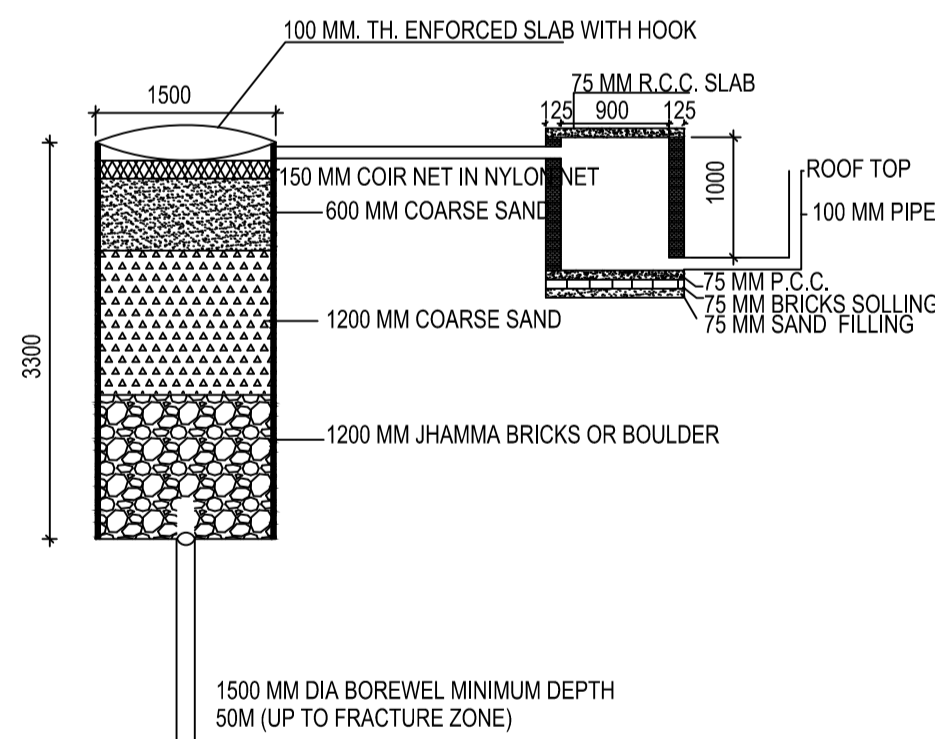

DETAIL OF GROUND WATER RECHARGING PIT WITH SILT TANK SCALE - N.T.S.

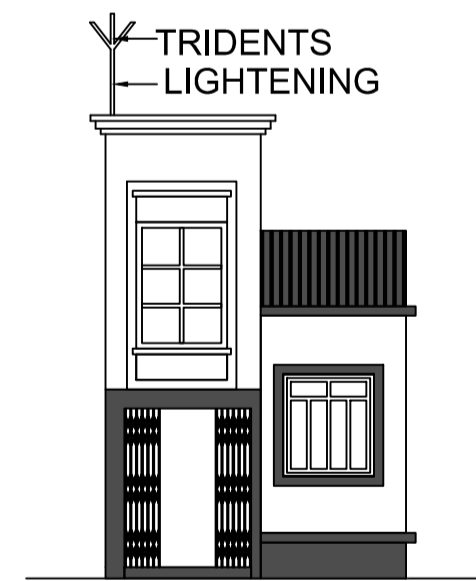

FRONT ELEVATION

LTP NAME AND SIGNATURE	STRUCTURAL ENG'S NAME AND SIGNATURE	BUILDER NAME AND SIGNATURE	DIGITAL SIGNATURE
RAJKISHOR KUMAR MNP/ENG/0003/2018			