

Proposal Basic Information	
Proposal File No.	MNP/BP/0037/W08/2022
Owner Name	PRAMILA DEVI
Khata No	169/1
Plot No	NA
Village Name	Madhupur Bazar
Use	Residential
SubUse	Bungalow/ Dwelling / Non Apartment

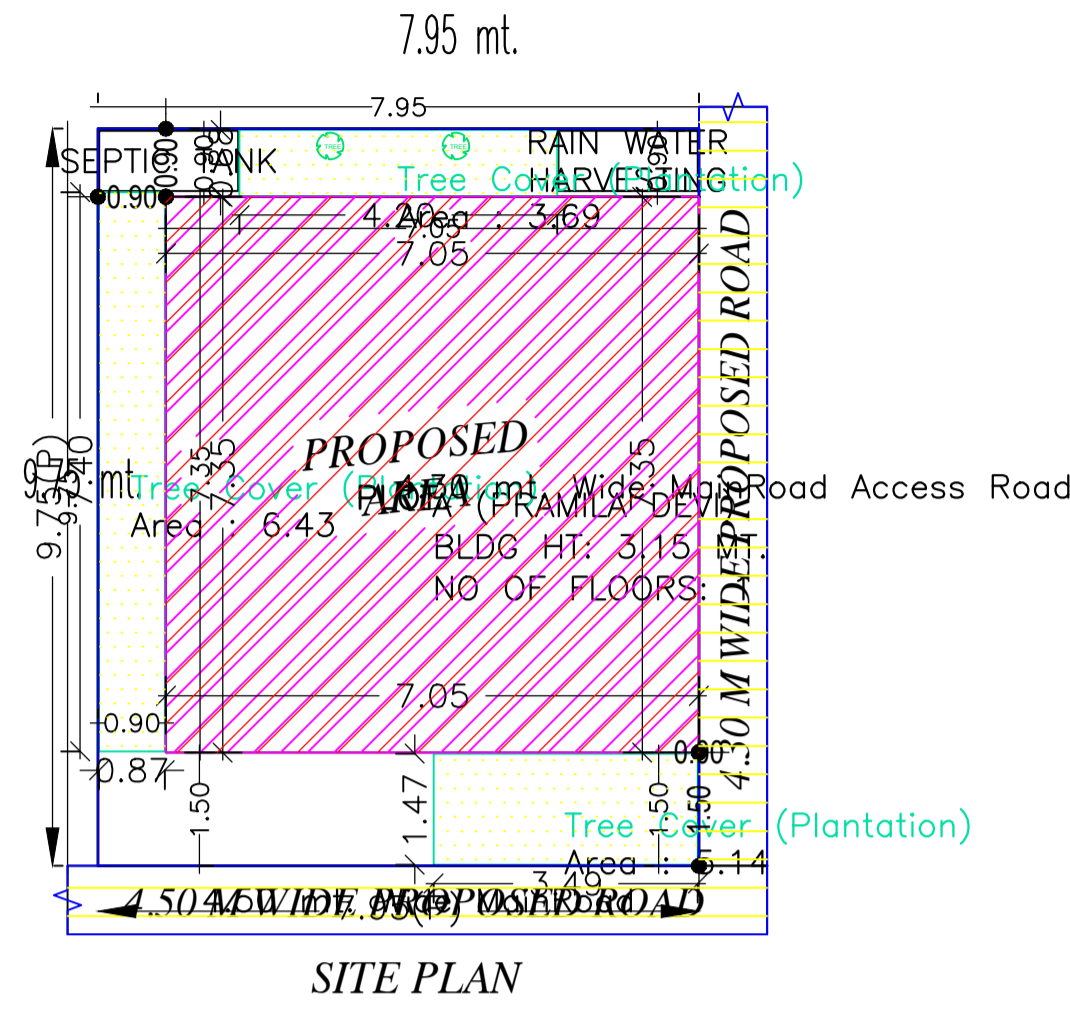

SITE PLAN

AREA STATEMENT		VERSION NO.: 1.0.62
MADHUPUR NAGAR PARISHAD		VERSION DATE: 16/10/2020
PROJECT DETAIL:		
Region: JHARKHAND URBAN LOCAL BODIES	Plot Use: Residential	
District: DEOGHAR	Plot SubUse: Bungalow/ Dwelling / Non Apartment	
Authority: MADHUPUR NAGAR PARISHAD	PlotNearby/ReligiousStructure: NA	
Inward No: MNP/BP/0037/W08/2022	Plot/SubPlot No: NA	
Application Type: General Proposal	North: Plot No. - LAND OF RAM LAKHAN SAH	
Project Type: Building Permission	South: Road Width - PRIVATE PASSAGE	
Nature of Development: New	East: Road Width - 4.5	
Location of Development Area: Old Area	West: Plot No. - VENDORS LAND	
AREA DETAILS:		
AREA OF PLOT (Minimum)	(A)	SQ.MT. 77.51
NET AREA OF PLOT(Gross Plot Area - Deduction from Gross Plot area)	(A-Deductions)	77.51
Deduction for Balance Plot Area(from Gross Plot Area)		
Common Plot		15.26
Total		15.26
BALANCE AREA OF PLOT(Net Plot Area - Recreational/Amenity space)	(A-Deductions)	62.26
PLOT AREA FOR COVERAGE(Net Plot Area)	(A-Deductions)	77.51
Plot Area for FAR (Net Plot Area + RoadWidening Area)	(A-Deductions)	77.51
COVERAGE CHECK		
Permissible Coverage area (70.00 %)		54.26
Proposed Coverage Area (66.85 %)		51.82
Total Prop. Coverage Area (66.85 %)		51.82
Balance coverage area (3.15 %)		2.44
FAR CHECK		
Perm. FAR Area (1.50)		116.26
Total Perm. FAR area		116.26
Residential FAR		103.64
Proposed FAR Area		103.64
Total Proposed FAR Area		103.64
Consumed FAR (Factor)		1.34
Balance FAR Area		12.62
BUILT UP AREA CHECK		
Total Proposed BuiltUp Area		103.64
ARCHITECT (Regd)	RAJKISHOR KUMAR	
ENGINEER (Regd)		
SUPERVISOR (Regd)		
OWNER (Regd)	PRAMILA DEVI	
DEVELOPMENT AUTHORITY		LOCAL BODY

FAR & Tenement Details (Table 4c-1)

Building	No. of Same Bldg	Total Built Up Area (Sq.mt.)	Proposed FAR Area (Sq.mt.) Resi.	Total FAR Area (Sq.mt.)	Total Consumed Additional FAR Area (Sq.mt.)	Tnmt (No.)
A (PRAMILA DEVI)	1	103.64	103.64	103.64	103.64	01
Grand Total :	1	103.64	103.64	103.64	103.64	01

Building USE/SUBUSE Details

Building Name	Building Use	Building SubUse	Building Structure
A (PRAMILA DEVI)	Residential	Bungalow/ Dwelling / Non Apartment	Non-Highrise

Buildingwise Floor FAR Details

Floor Name	Building Name		Total	
	Proposed Built Up Area (Sq.mt.)	Proposed FAR Area (Sq.mt.)	Total Proposed Built Up Area (Sq.mt.)	Total FAR Area (Sq.mt.)
Basement Floor	51.82	51.82	51.82	51.82
Ground Floor	51.82	51.82	51.82	51.82
Terrace Floor	0.00	0.00	0.00	0.00
Total :	103.64	103.64	103.64	103.64

COLOR INDEX	
PLOT BOUNDARY	Black
ABUTTING ROAD	Green
PROPOSED CONSTRUCTION	Red
COMMON PLOT	Yellow
ROAD WIDENING AREA	Blue
EXISTING (To be retained)	Orange
EXISTING (To be demolished)	Light Blue

LTP NAME AND SIGNATURE	STRUCTURAL ENG'S NAME AND SIGNATURE	BUILDER NAME AND SIGNATURE	DIGITAL SIGNATURE
RAJKISHOR KUMAR MNP/ENG/0003/2018			

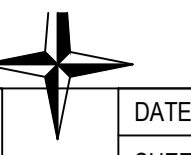

Proposal Basic Information	
Proposal File No.	MNP/EP/0037/W08/2022
Owner Name	PRAMILA DEVI
Khata No	169/1
Plot No	NA
Village Name	Madhupur Bazar
Use	Residential
SubUse	Bungalow/ Dwelling / Non Apartment

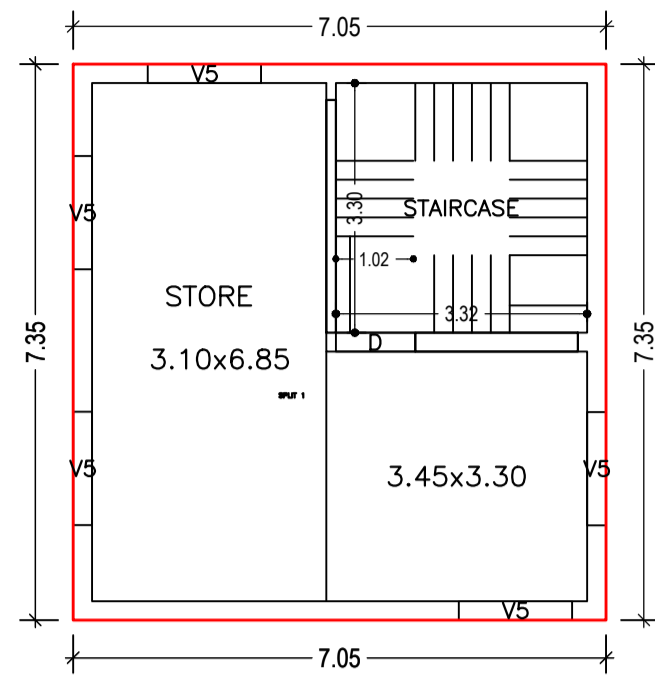

BASEMENT FLOOR PLAN
(Proposed)
(SCALE 1:100)

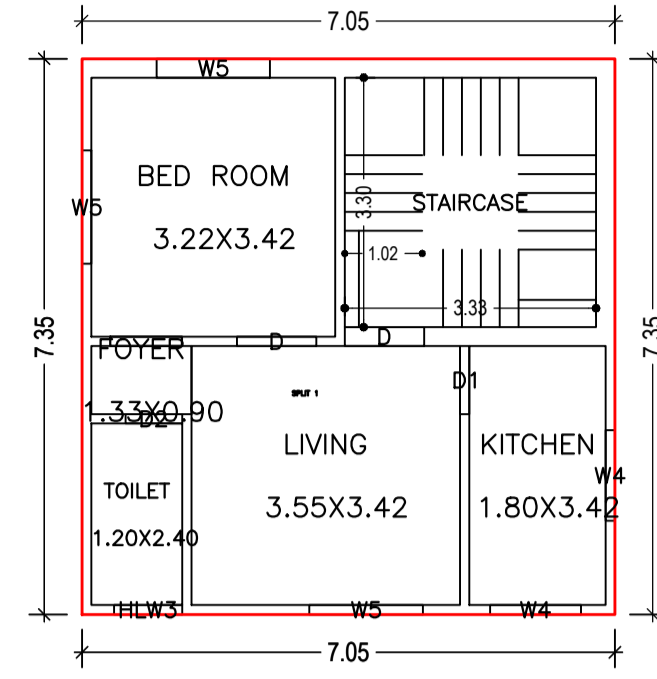

GROUND FLOOR PLAN
(Proposed)
(SCALE 1:100)

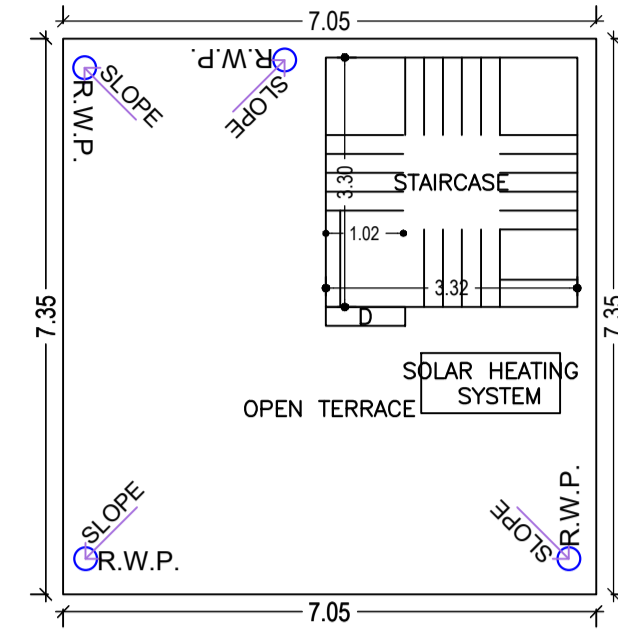

TERRACE FLOOR PLAN
(SCALE 1:100)

UnitBUA Table for Building :A (PRAMILA DEVI)

FLOOR	Name	UnitBUA Type	UnitBUA Area	Carpet Area	No. of Rooms	No. of Tenement
BASEMENT FLOOR PLAN	SPLIT 1	FLAT	69.94	68.90	1	1
GROUND FLOOR PLAN	SPLIT 1	FLAT	0.00	0.00	5	0
Total:	-	-	69.94	68.90	6	1

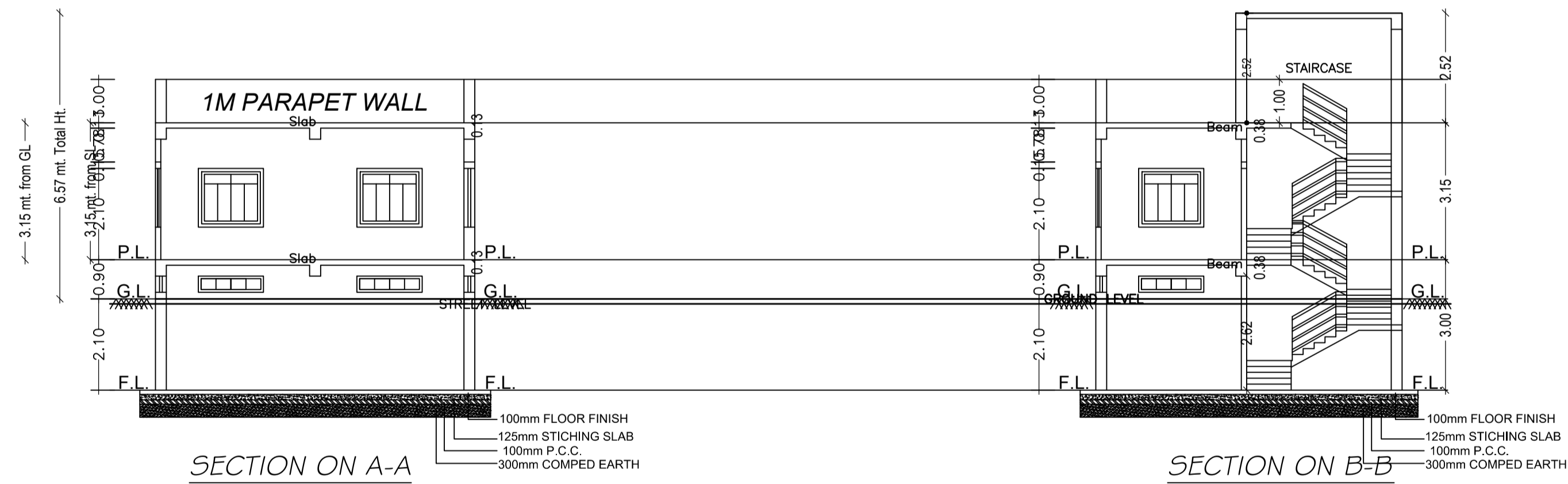

SCHEDULE OF DOOR:

BUILDING NAME	NAME	LENGTH	HEIGHT	NOS
A (PRAMILA DEVI)	D2	0.75	2.10	01
A (PRAMILA DEVI)	D1	0.90	2.10	01
A (PRAMILA DEVI)	D	1.05	2.10	03

SCHEDULE OF WINDOW/VENTILATION:

BUILDING NAME	NAME	LENGTH	HEIGHT	NOS
A (PRAMILA DEVI)	HLW3	0.90	0.60	01
A (PRAMILA DEVI)	W4	1.20	1.35	02
A (PRAMILA DEVI)	V5	1.50	0.45	05
A (PRAMILA DEVI)	W5	1.50	1.35	03

Building :A (PRAMILA DEVI)

Floor Name	Total Built Up Area (Sq.mt.)	Proposed FAR Area (Sq.mt.) Resi.	Total FAR Area (Sq.mt.)	Total Consumed Additional FAR Area (Sq.mt.)	Tnmt (No.)
Basement Floor	51.82	51.82	51.82	51.82	01
Ground Floor	51.82	51.82	51.82	51.82	00
Terrace Floor	0.00	0.00	0.00	0.00	00
Total:	103.64	103.64	103.64	103.64	01
Total Number of Same Buildings	1				
Total:	103.64	103.64	103.64	103.64	01

LTP NAME AND SIGNATURE	STRUCTURAL ENG'S NAME AND SIGNATURE	BUILDER NAME AND SIGNATURE	DIGITAL SIGNATURE
RAJKISHOR KUMAR MNP/ENG/0003/2018			

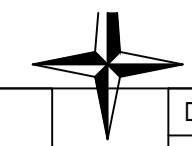

Proposal Basic Information	
Proposal File No.	MNP/IBP/0037/W08/2022
Owner Name	PRAMILA DEVI
Khata No	169/1
Plot No	NA
Village Name	Madhupur Bazar
Use	Residential
SubUse	Bungalow/ Dwelling / Non Apartment

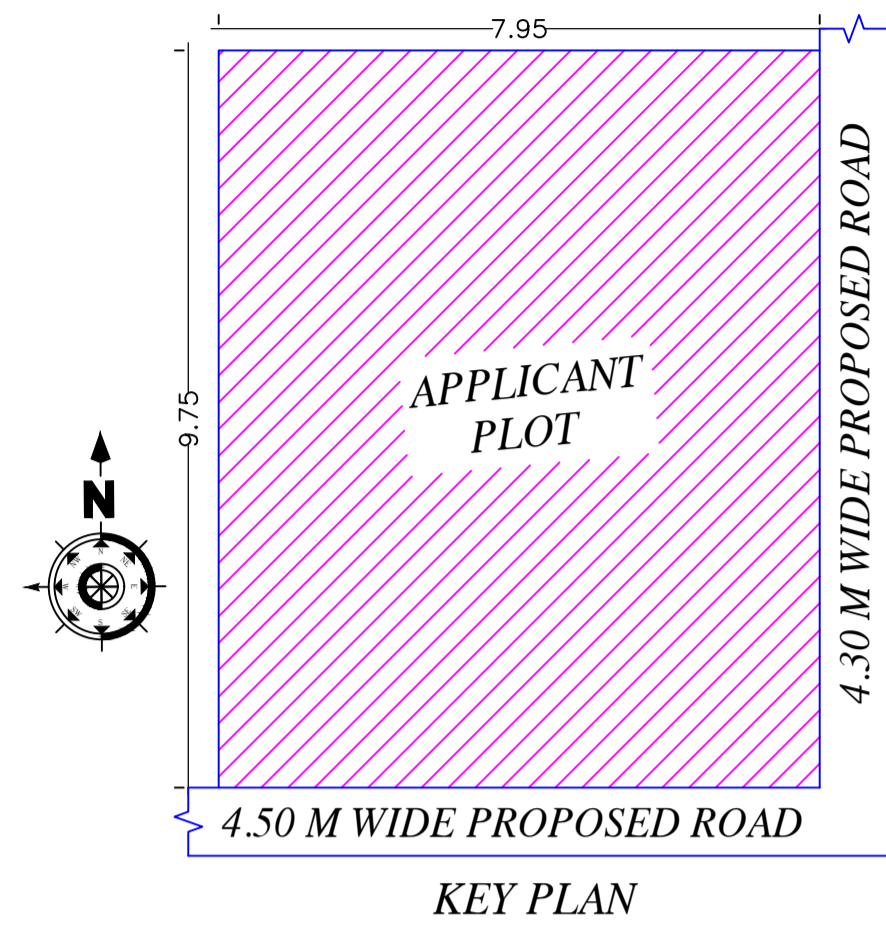

APPLICANT PLOT

4.50 M WIDE PROPOSED ROAD

SHANTI NIKETAN DURGA MANDIR

LOCATION MAP

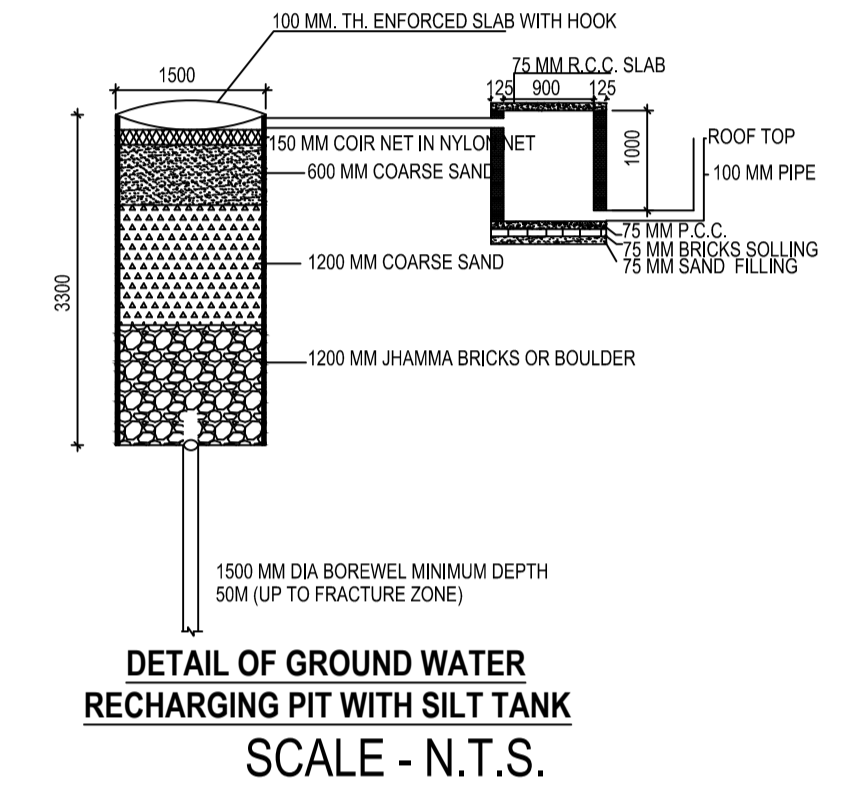
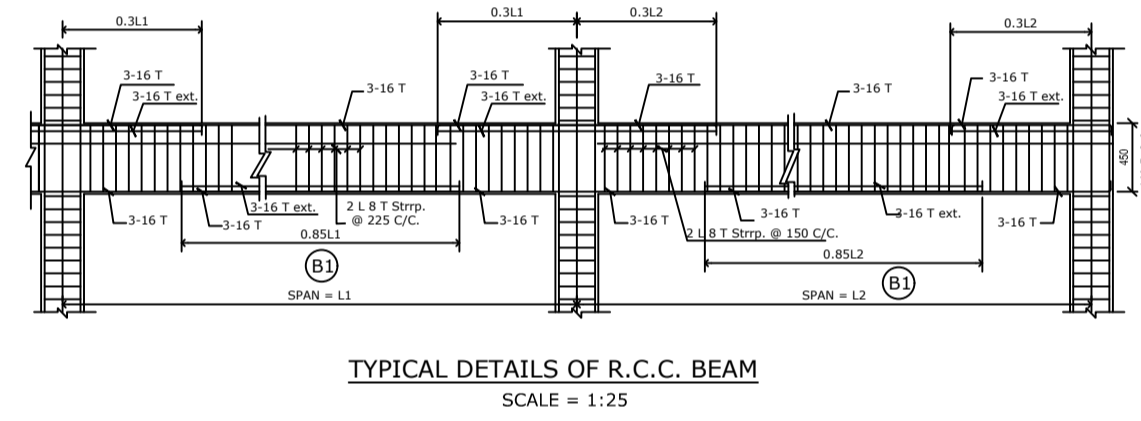
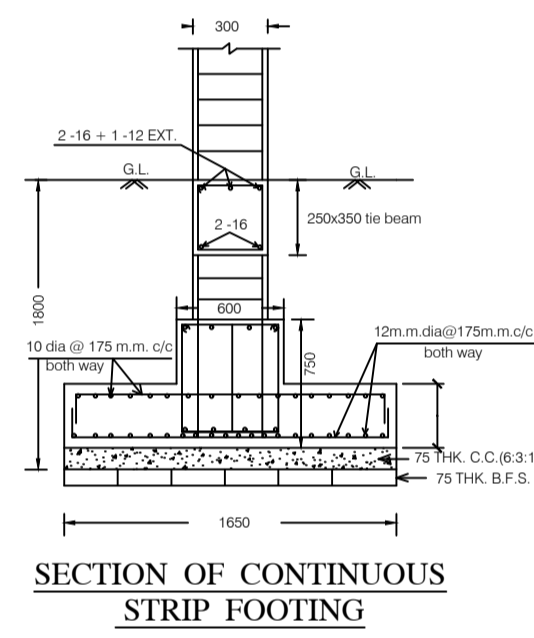
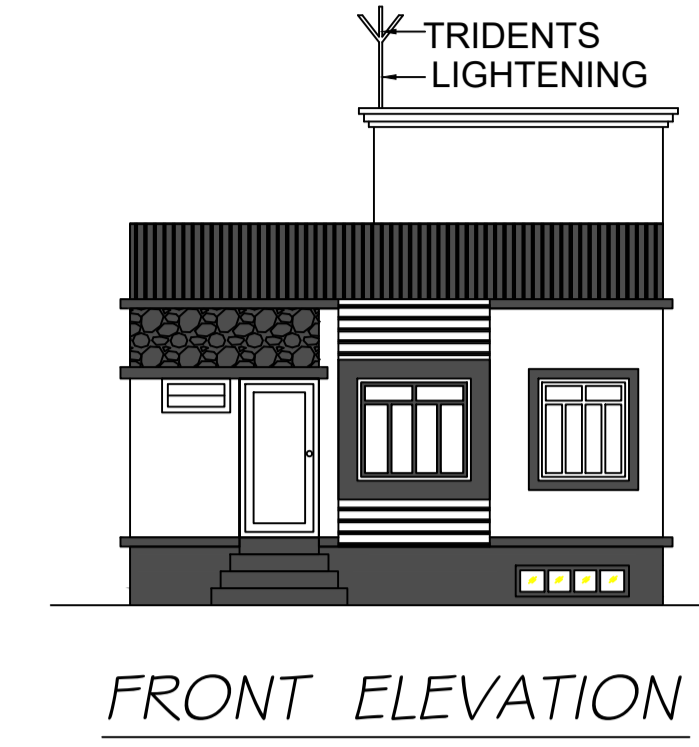
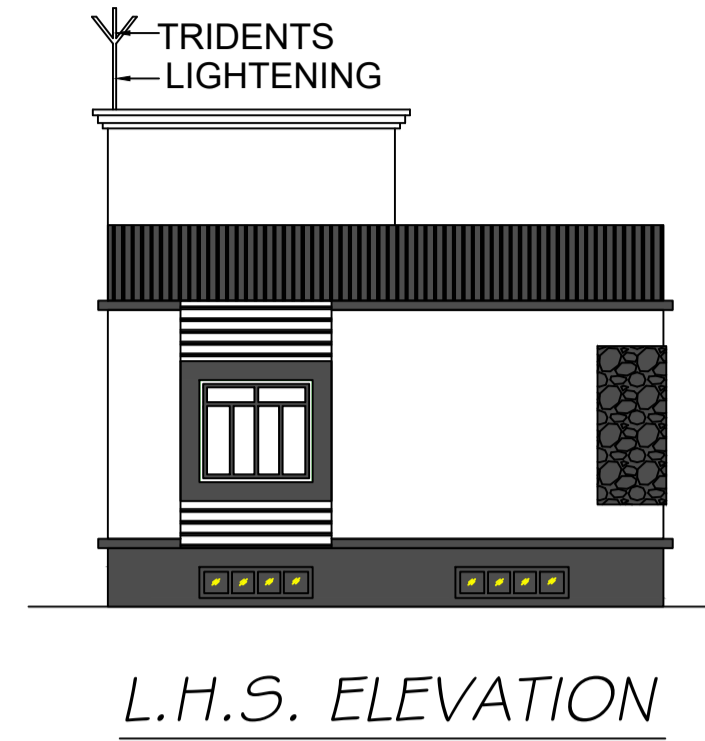

This is certify that the structure design is in accordance with the latest I-S code(I-S 875,I-S456-2002, I-S 1893-2000) for design & loading conditions (Sessmic/wind/dead/live) and other all parameters are taken in account for safetyof the structure.

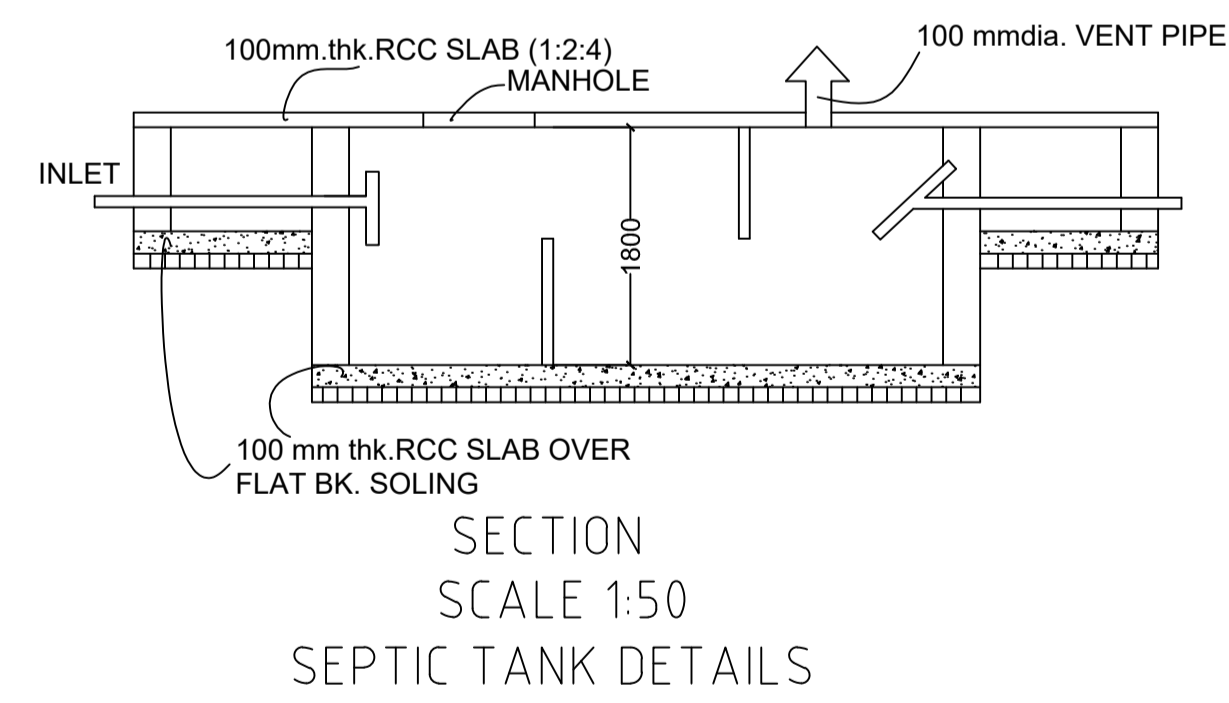
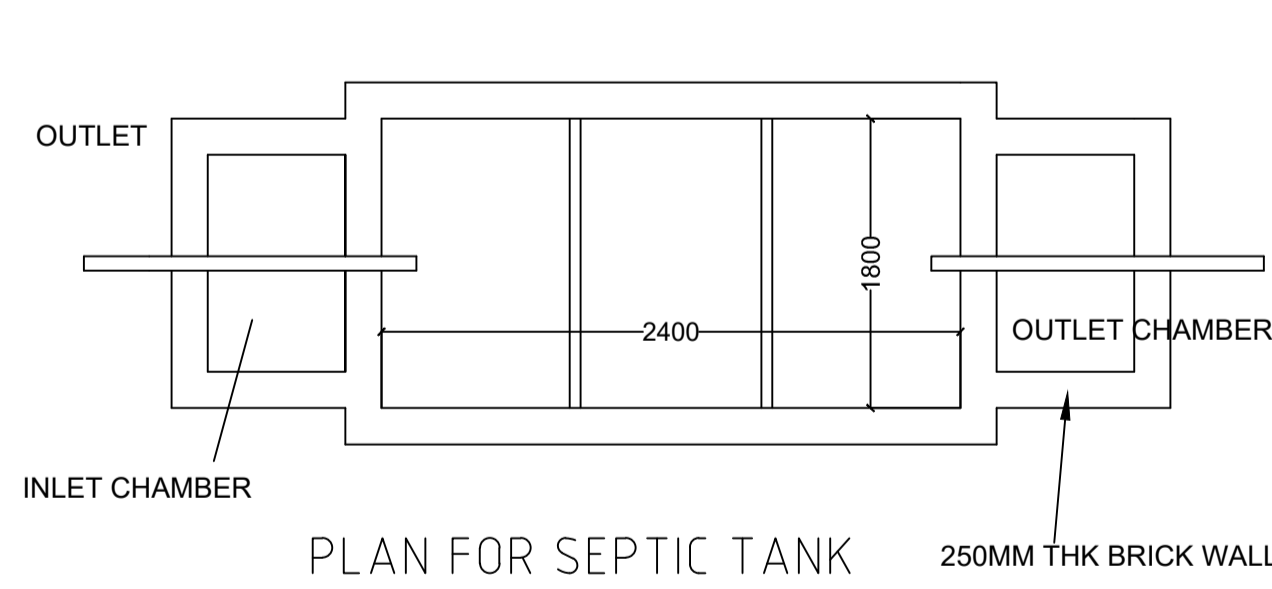

LTP NAME AND SIGNATURE	STRUCTURAL ENG'S NAME AND SIGNATURE	BUILDER NAME AND SIGNATURE	DIGITAL SIGNATURE
RAJKISHOR KUMAR MNP/ENG/0003/2018			