

Proposal Basic Information	
Proposal File No.	MNP/EP/0063/W21/2022
Owner Name	CHINTA DEVI
Khata No	220/1/GHA
Plot No	0/1
Village Name	Patharchptti
Use	Residential
SubUse	Bungalow/ Dwelling / Non Apartment

AREA STATEMENT		VERSION NO.: 1.0.64
MADHUPUR NAGAR PARISHAD		VERSION DATE: 16/10/2020
PROJECT DETAIL:		
Region: JHARKHAND URBAN LOCAL BODIES	Plot Use: Residential	
District: DEOGHAR	Plot SubUse: Bungalow/ Dwelling / Non Apartment	
Authority: MADHUPUR NAGAR PARISHAD	PlotNearby/ReligiousStructure: NA	
Inward No: MNP/EP/0063/W21/2022	Plot/SubPlot No: 0/1	
Application Type: General Proposal	North: Road Width - 1.8	
Project Type: Building Permission	South: Plot No. - LAND OF B.N TIWARI	
Nature of Development: New	East: Plot No. - SUB PLOT NO- A	
Location of Development Area: Old Area	West: Plot No. - SUB PLOT NO-C	
AREA DETAILS:		SQ.MT.
AREA OF PLOT (Minimum)	(A)	70.20
Deduction for NetPlot Area		
Road Widening Area		6.62
Total		6.62
NET AREA OF PLOT(Gross Plot Area - Deduction from Gross Plot area)	(A-Deductions)	63.58
Deduction for Balance Plot Area(from Gross Plot Area)		
Road Widening Area		6.62
Common Plot		11.51
Total		18.14
BALANCE AREA OF PLOT(Net Plot Area - Recreational/Amenity space)	(A-Deductions)	52.06
PLOT AREA FOR COVERAGE(Net Plot Area)	(A-Deductions)	63.58
Plot Area for FAR (Net Plot Area + RoadWidening Area)	(A-Deductions)	63.58
COVERAGE CHECK		
Permissible Coverage area ( 70.00 % )		44.51
Proposed Coverage Area ( 59.74 % )		37.98
Total Prop. Coverage Area ( 59.74 % )		37.98
Balance coverage area ( 10.27 % )		6.53
FAR CHECK		
Perm. FAR Area ( 1.200 )		76.30
Total Perm. FAR area		76.30
Residential FAR		75.95
Proposed FAR Area		75.95
Total Proposed FAR Area		75.95
Consumed FAR (Factor)		1.19
Balance FAR Area		0.35
BUILT UP AREA CHECK		
Total Proposed BuiltUp Area		75.96
ARCHITECT (Regd)	RAJKISHOR KUMAR	
ENGINEER (Regd)		
SUPERVISOR (Regd)		
OWNER (Regd)	CHINTA DEVI	
DEVELOPMENT AUTHORITY	LOCAL BODY	

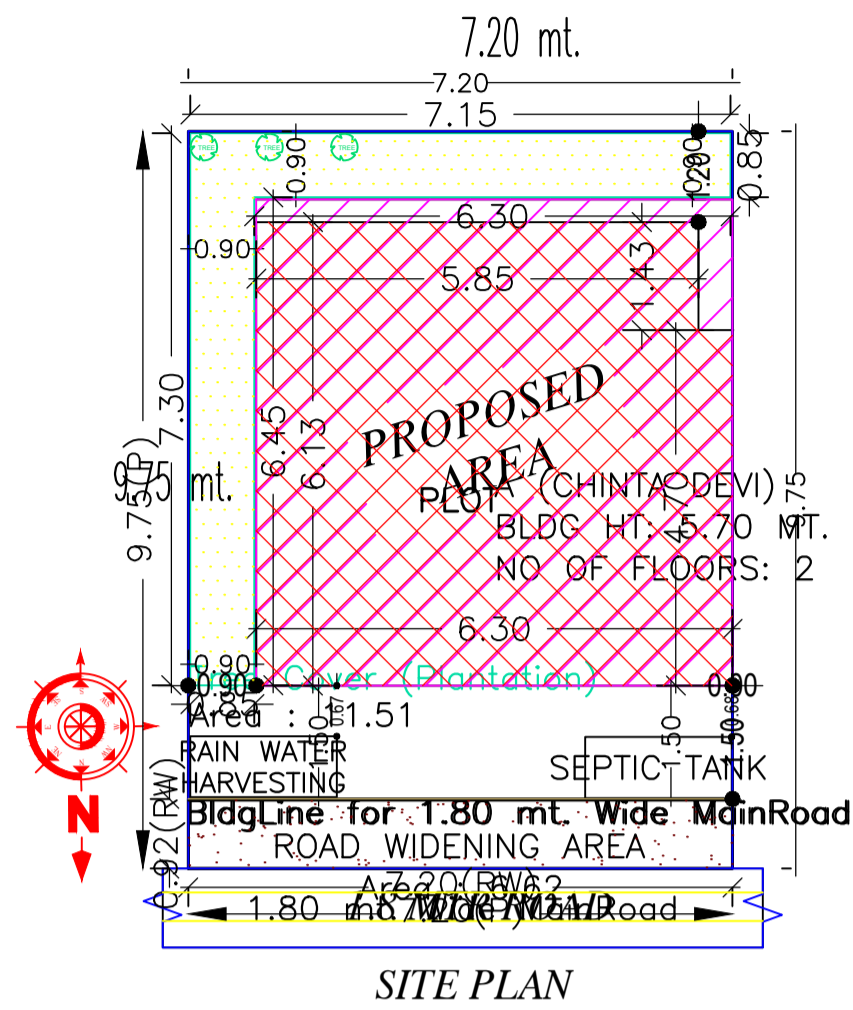

SITE PLAN

COLOR INDEX	
PLOT BOUNDARY	Black
ABUTTING ROAD	Green
PROPOSED CONSTRUCTION	Red
COMMON PLOT	Yellow
ROAD WIDENING AREA	Blue
EXISTING (To be retained)	Light Blue
EXISTING (To be demolished)	Orange

Buildingwise Floor FAR Details

Floor Name	Building Name A (CHINTA DEVI)		Total	
	Proposed Built Up Area (Sq.mt.)	Proposed FAR Area (Sq.mt.)	Total Proposed Built Up Area (Sq.mt.)	Total FAR Area (Sq.mt.)
Ground Floor	37.98	37.98	37.98	37.98
First Floor	37.98	37.98	37.98	37.98
Terrace Floor	0.00	0.00	0.00	0.00
Total :	75.96	75.96	75.96	75.96

Building USE/SUBUSE Details

Building Name	Building Use	Building SubUse	Building Structure
A (CHINTA DEVI)	Residential	Bungalow/ Dwelling / Non Apartment	Non-Highrise

FAR & Tenement Details (Table 4c-1)

Building	No. of Same Bldg	Total Built Up Area (Sq.mt.)	Proposed FAR Area (Sq.mt.) Resi.	Total FAR Area (Sq.mt.)	Total Consumed Additional FAR Area (Sq.mt.)	Trmt (No.)
A (CHINTA DEVI)	1	75.96	75.96	75.96	75.96	01
Grand Total :	1	75.96	75.96	75.96	75.96	01

LTP NAME AND SIGNATURE	STRUCTURAL ENG'S NAME AND SIGNATURE	BUILDER NAME AND SIGNATURE	DIGITAL SIGNATURE
RAJKISHOR KUMAR MNP/ENG/0003/2018			

Proposal Basic Information

Proposal File No.	MNP/ENG/0063/W21/2022
Owner Name	CHINTA DEVI
Khata No	220/1/GHA
Plot No	0/1
Village Name	Patharchptti
Use	Residential
SubUse	Bungalow/ Dwelling / Non Apartment

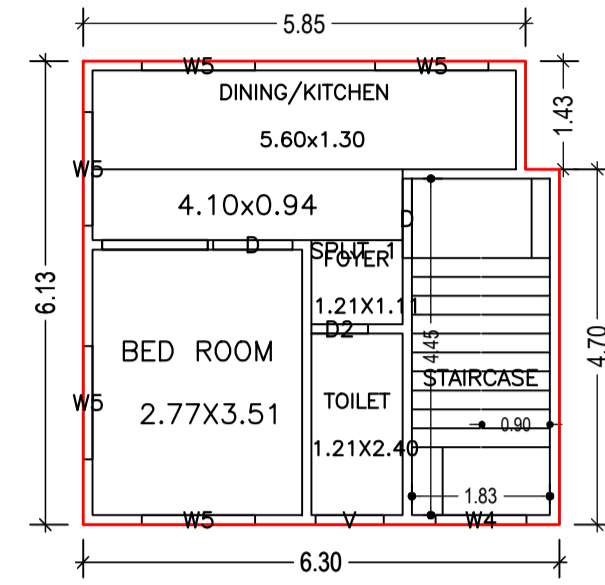

FIRST FLOOR PLAN  
(Proposed)  
(SCALE 1:100)

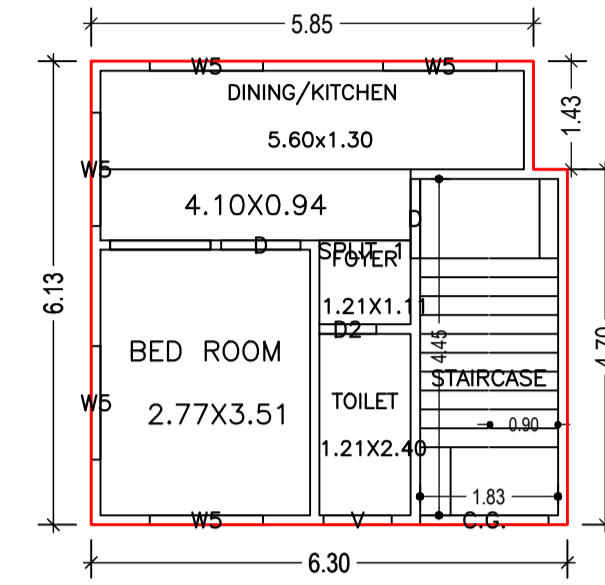

GROUND FLOOR PLAN  
(Proposed)  
(SCALE 1:100)

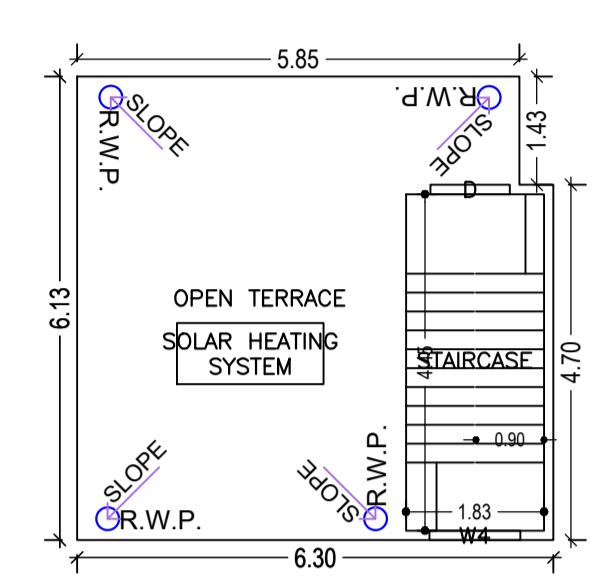

TERRACE FLOOR PLAN  
(SCALE 1:100)

Building :A (CHINTA DEVI)

Floor Name	Total Built Up Area (Sq.mt.)	Proposed FAR Area (Sq.mt.) Resi.	Total FAR Area (Sq.mt.)	Total Consumed Additional FAR Area (Sq.mt.)	Tnmt (No.)
Ground Floor	37.98	37.98	37.98	37.98	01
First Floor	37.98	37.98	37.98	37.98	00
Terrace Floor	0.00	0.00	0.00	0.00	00
Total :	75.96	75.96	75.96	75.96	01
Total Number of Same Buildings :	1				
Total :	75.96	75.96	75.96	75.96	01

SCHEDULE OF DOOR:

BUILDING NAME	NAME	LENGTH	HEIGHT	NOS
A (CHINTA DEVI)	D2	0.75	2.10	02
A (CHINTA DEVI)	D	1.05	2.10	04

SCHEDULE OF WINDOW/VENTILATION:

BUILDING NAME	NAME	LENGTH	HEIGHT	NOS
A (CHINTA DEVI)	V	0.90	0.60	02
A (CHINTA DEVI)	W4	1.20	1.35	02
A (CHINTA DEVI)	W5	1.50	1.35	10

UnitBUA Table for Building :A (CHINTA DEVI)

FLOOR	Name	UnitBUA Type	UnitBUA Area	Carpet Area	No. of Rooms	No. of Tenement
FIRST FLOOR PLAN	SPLIT 1	FLAT	0.00	0.00	4	0
GROUND FLOOR PLAN	SPLIT 1	FLAT	53.62	53.28	4	1
Total:	-	-	53.62	53.28	8	1

LTP NAME AND SIGNATURE	STRUCTURAL ENG'S NAME AND SIGNATURE	BUILDER NAME AND SIGNATURE	DIGITAL SIGNATURE
RAJKISHOR KUMAR MNP/ENG/0003/2018			

Proposal Basic Information	
Proposal File No.	MNP/EP/0063/W21/2022
Owner Name	CHINTA DEVI
Khata No	220/1/GHA
Plot No	0/1
Village Name	Patharchptti
Use	Residential
SubUse	Bungalow/ Dwelling / Non Apartment

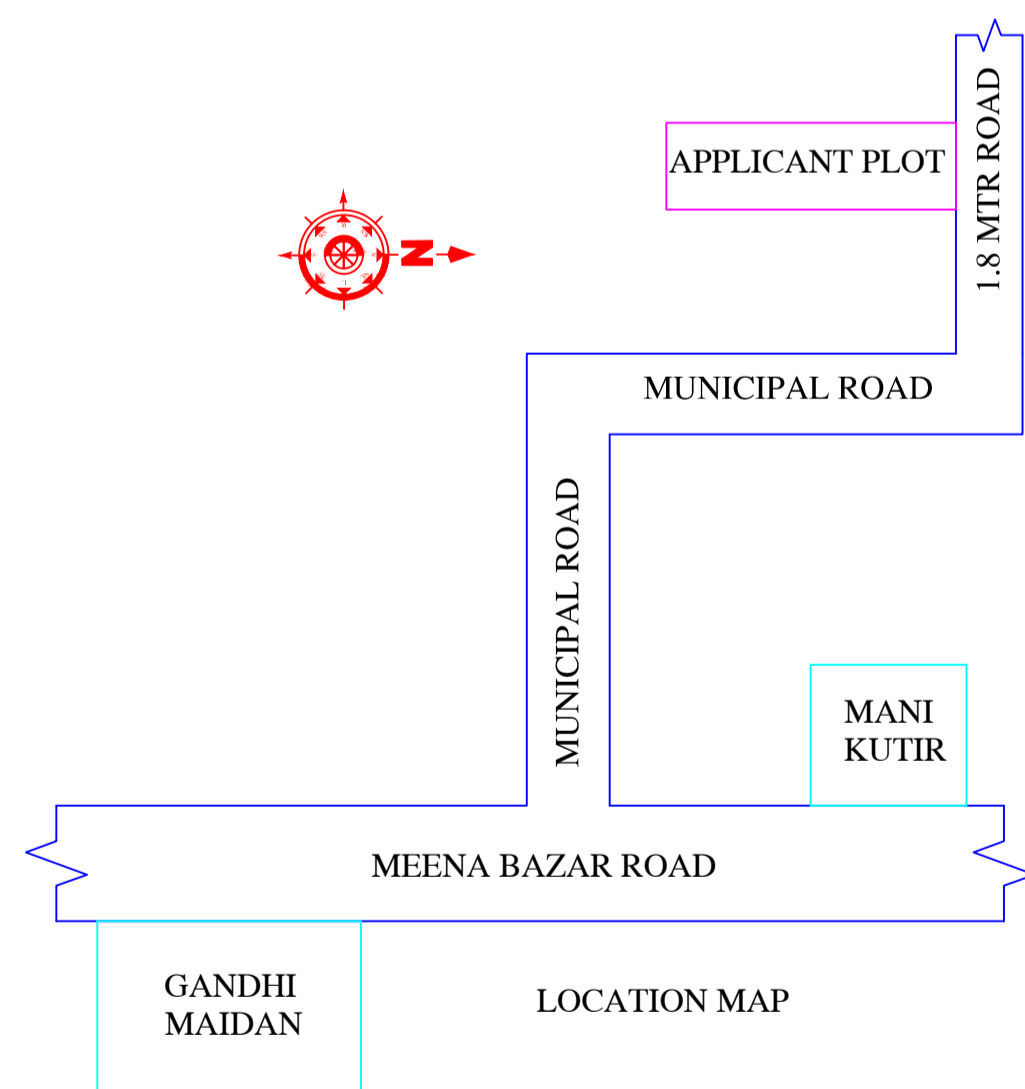
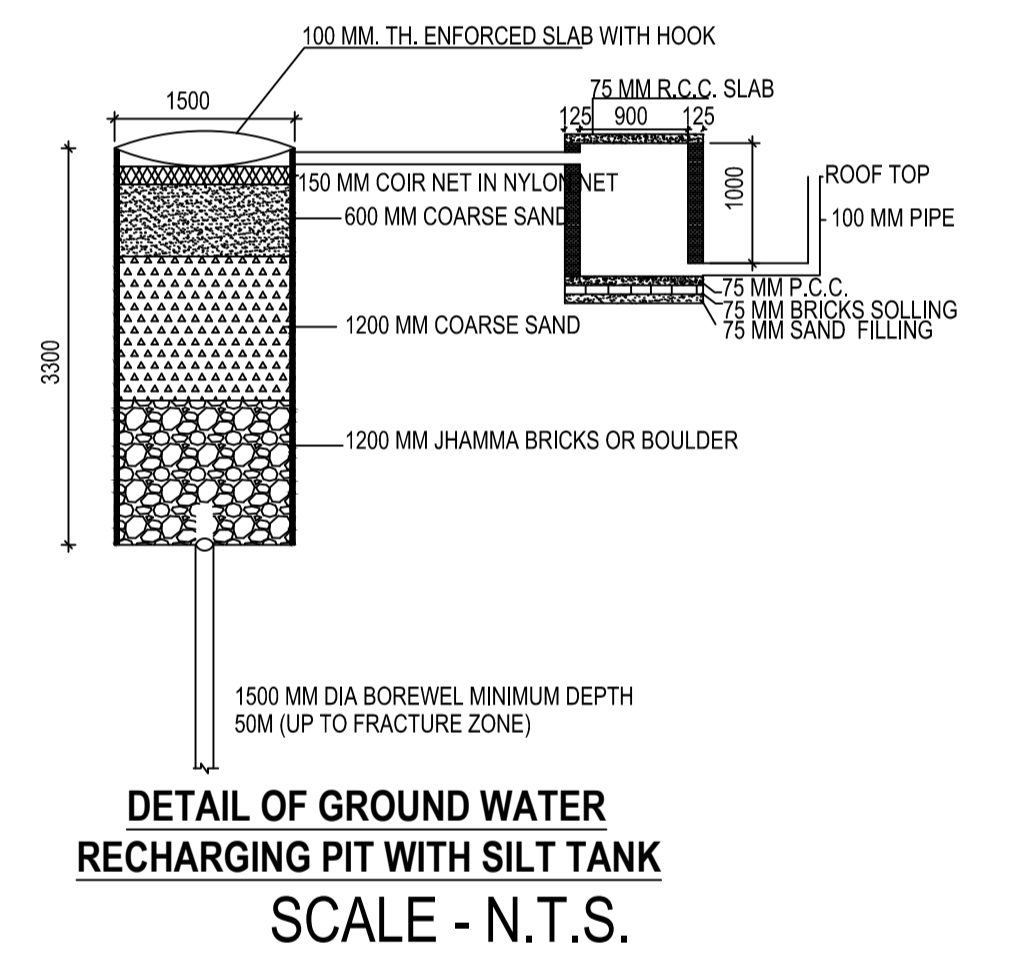
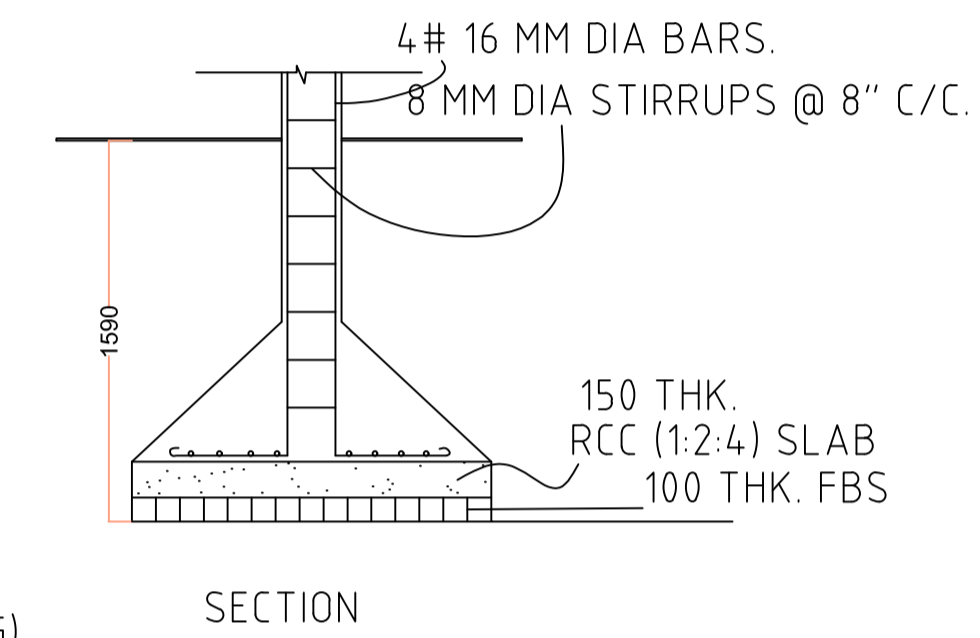
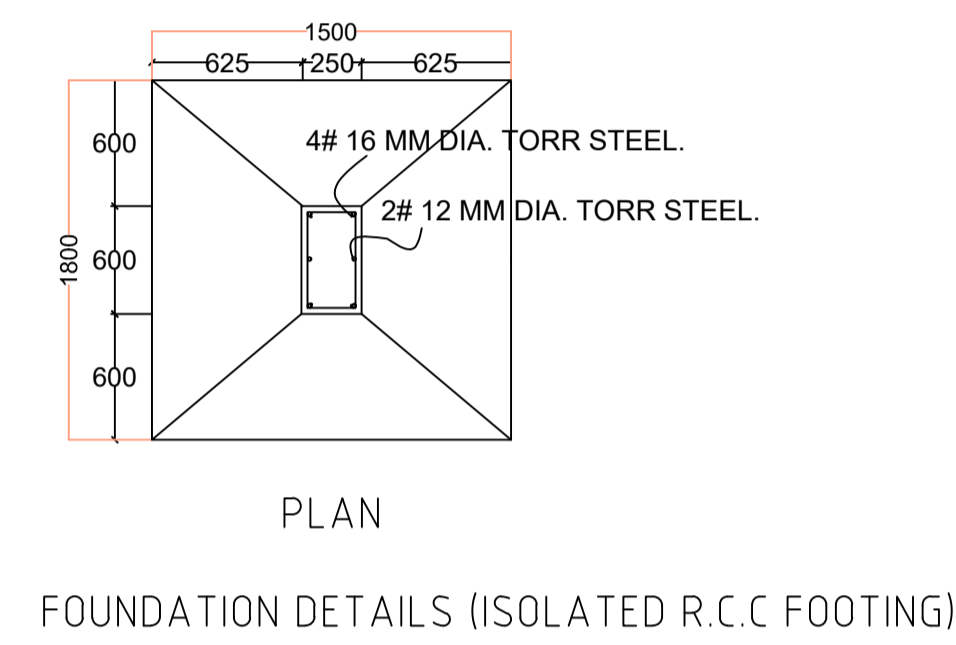
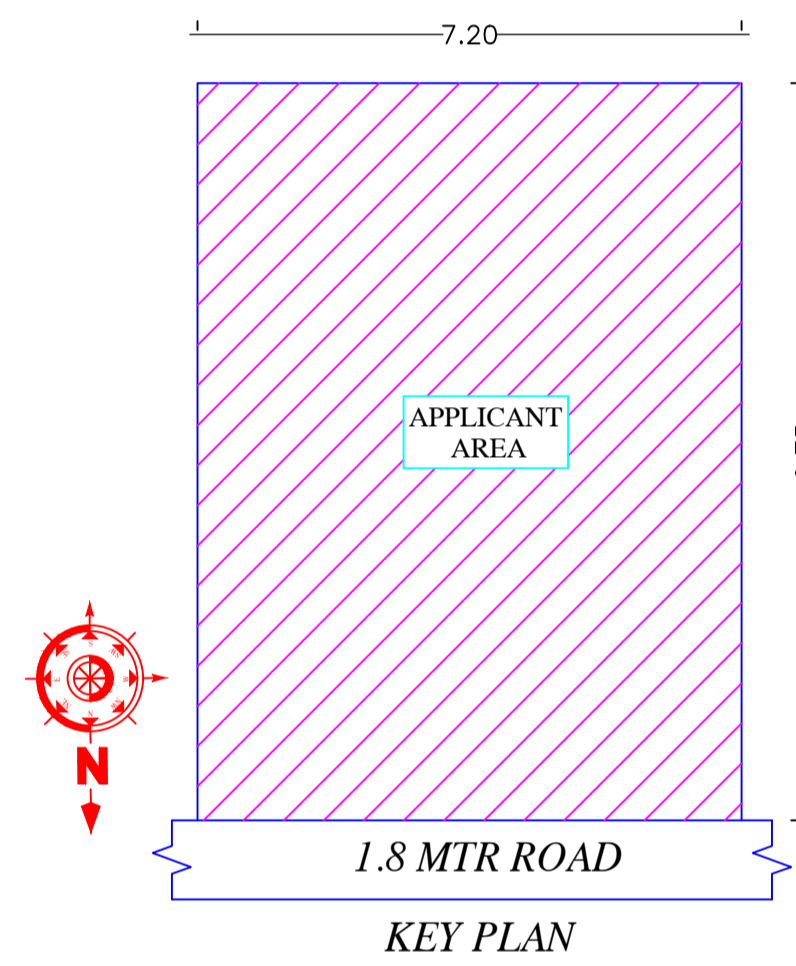
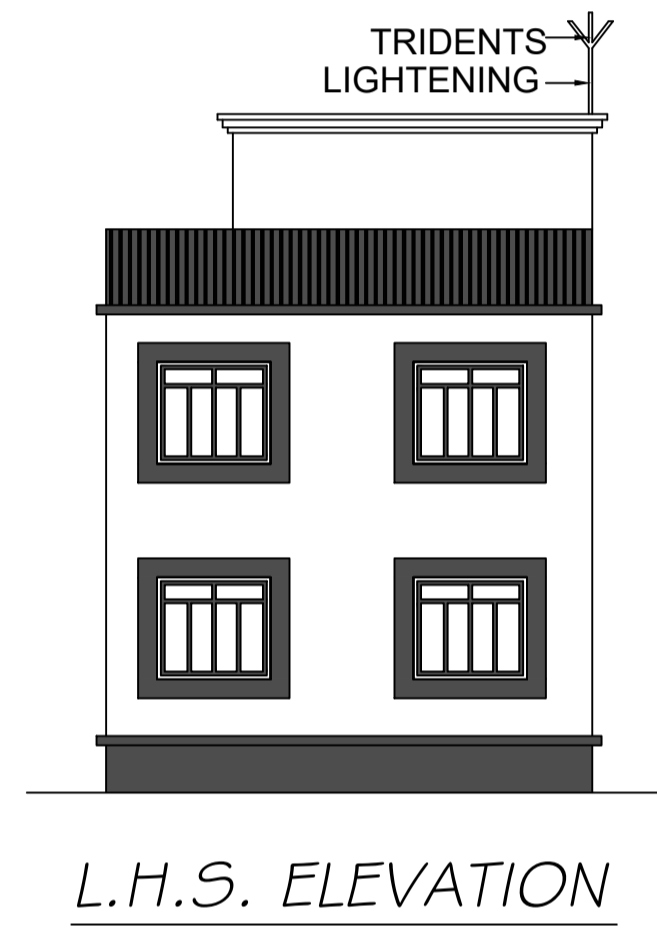
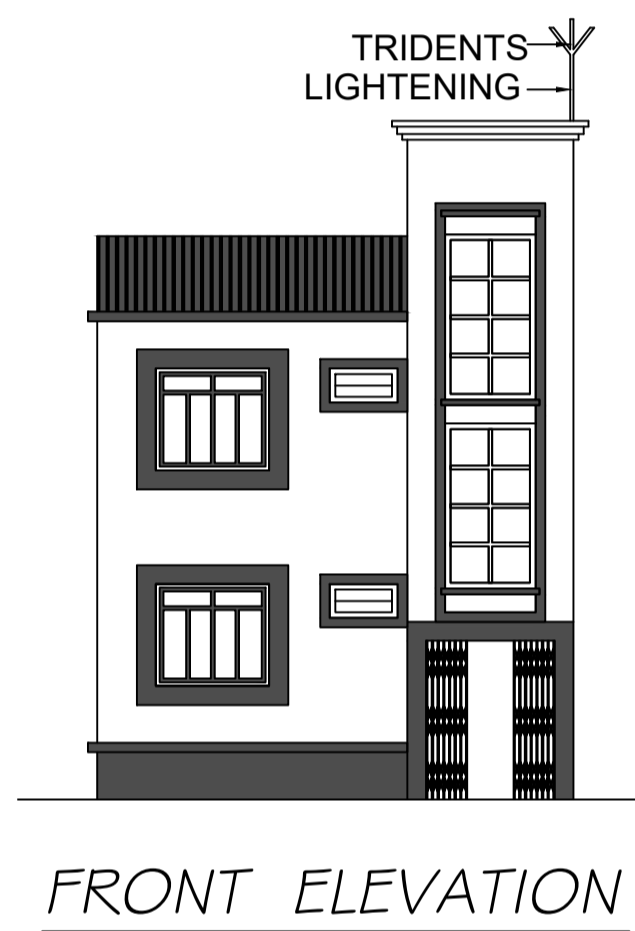
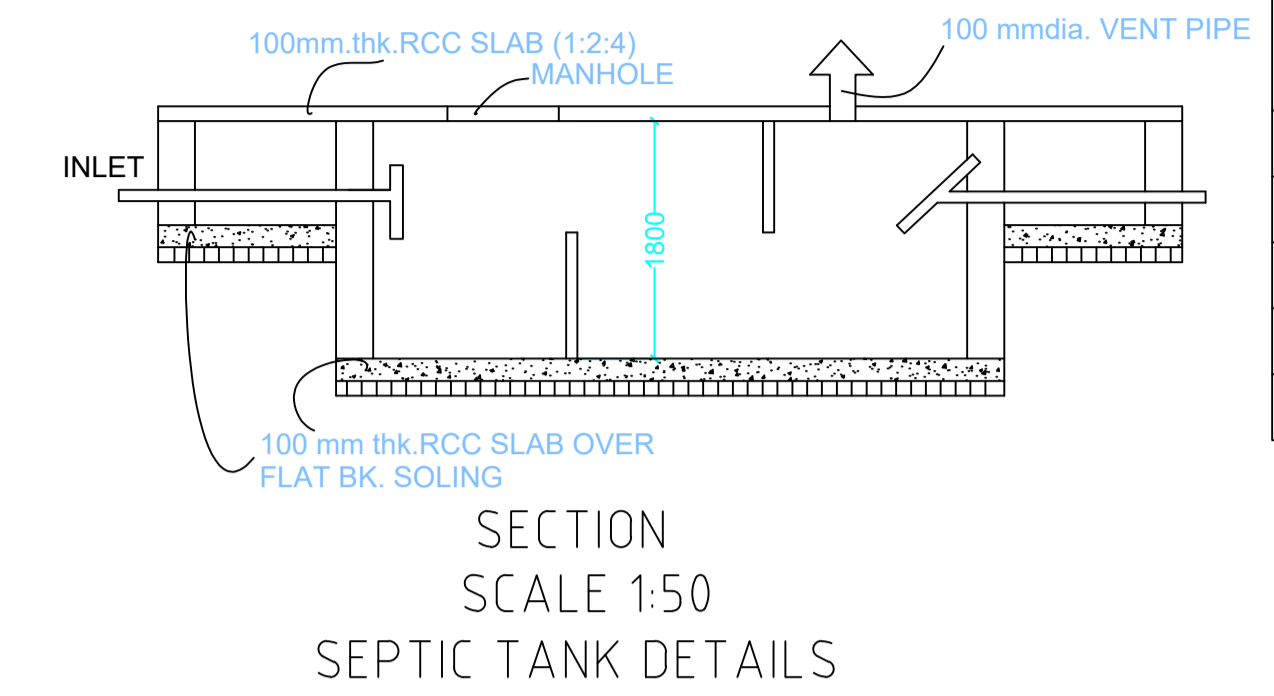
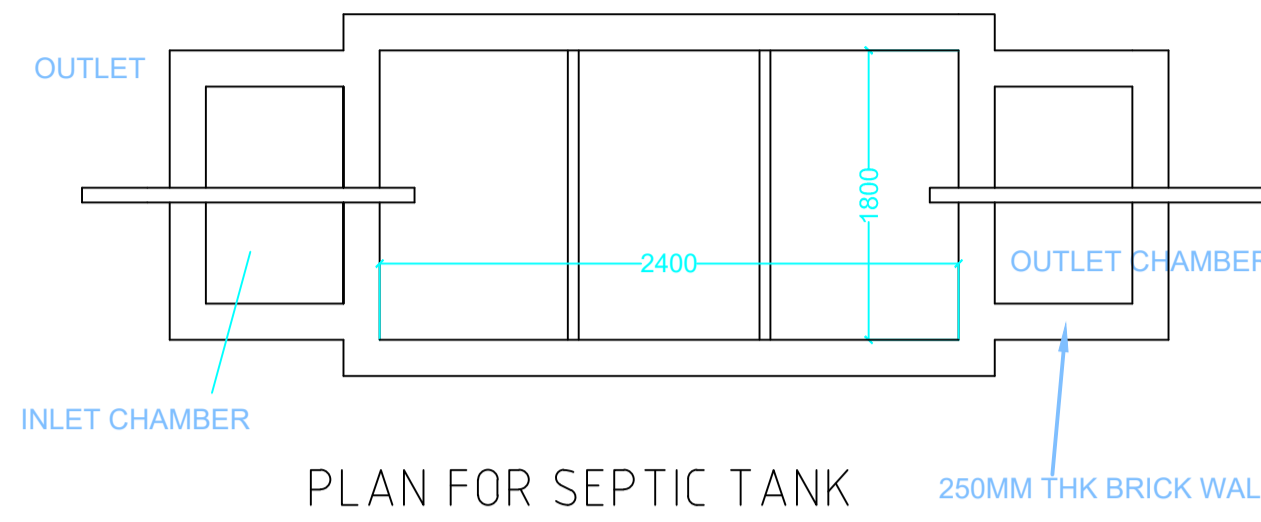
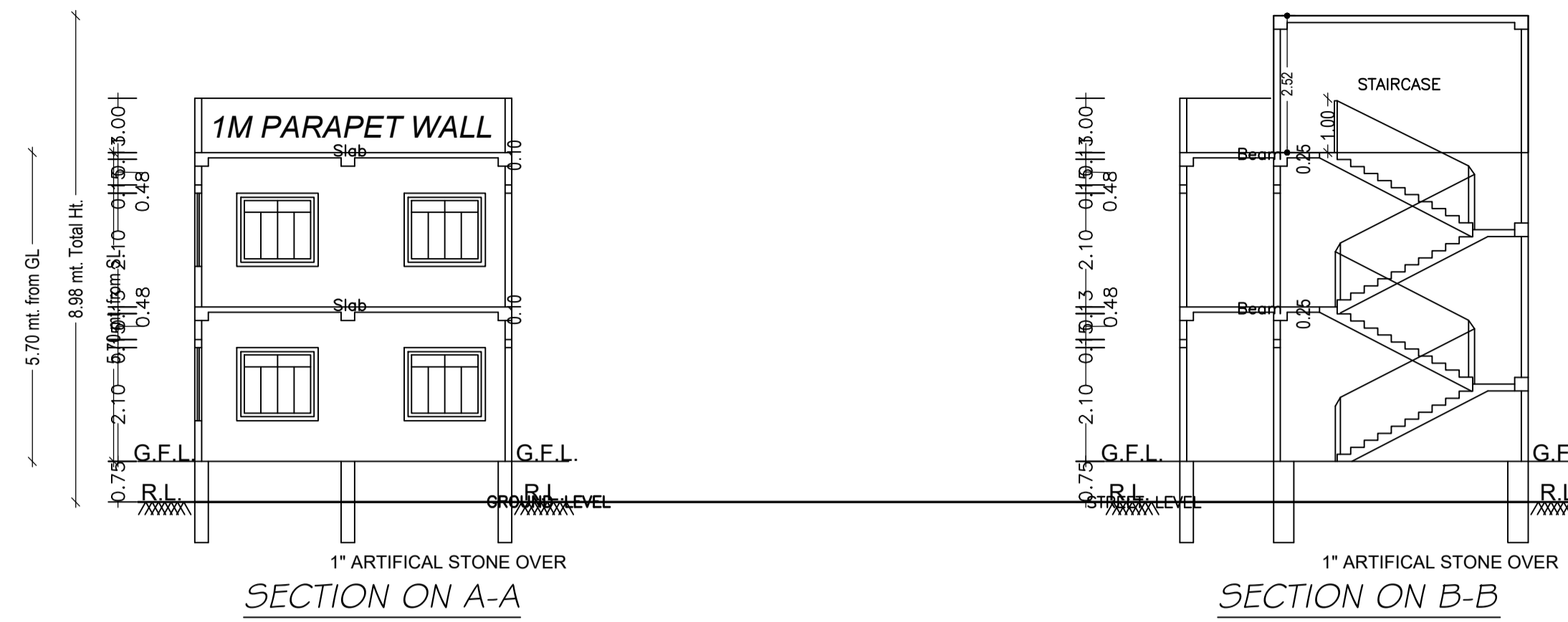

This is certify that the structure design is in accordance with the latest I-S code(I-S 875,I-S456-2002, I-S 1893-2000) for design & loading conditions (Sessmic/wind/dead/live) and other all parameters are taken in account for safetyof the structure.

LTP NAME AND SIGNATURE	STRUCTURAL ENG'S NAME AND SIGNATURE	BUILDER NAME AND SIGNATURE	DIGITAL SIGNATURE
RAJKISHOR KUMAR MNP/ENG/0003/2018			