

Proposal Basic Information	
Proposal File No.	MNP/BP/0064/W02/2022
Owner Name	SMT. JYOTI KUMARI
Khata No	1/33A & 1/33
Plot No	1/33A & 1/33
Village Name	Sapha
Use	Residential
SubUse	Bungalow/ Dwelling / Non Apartment

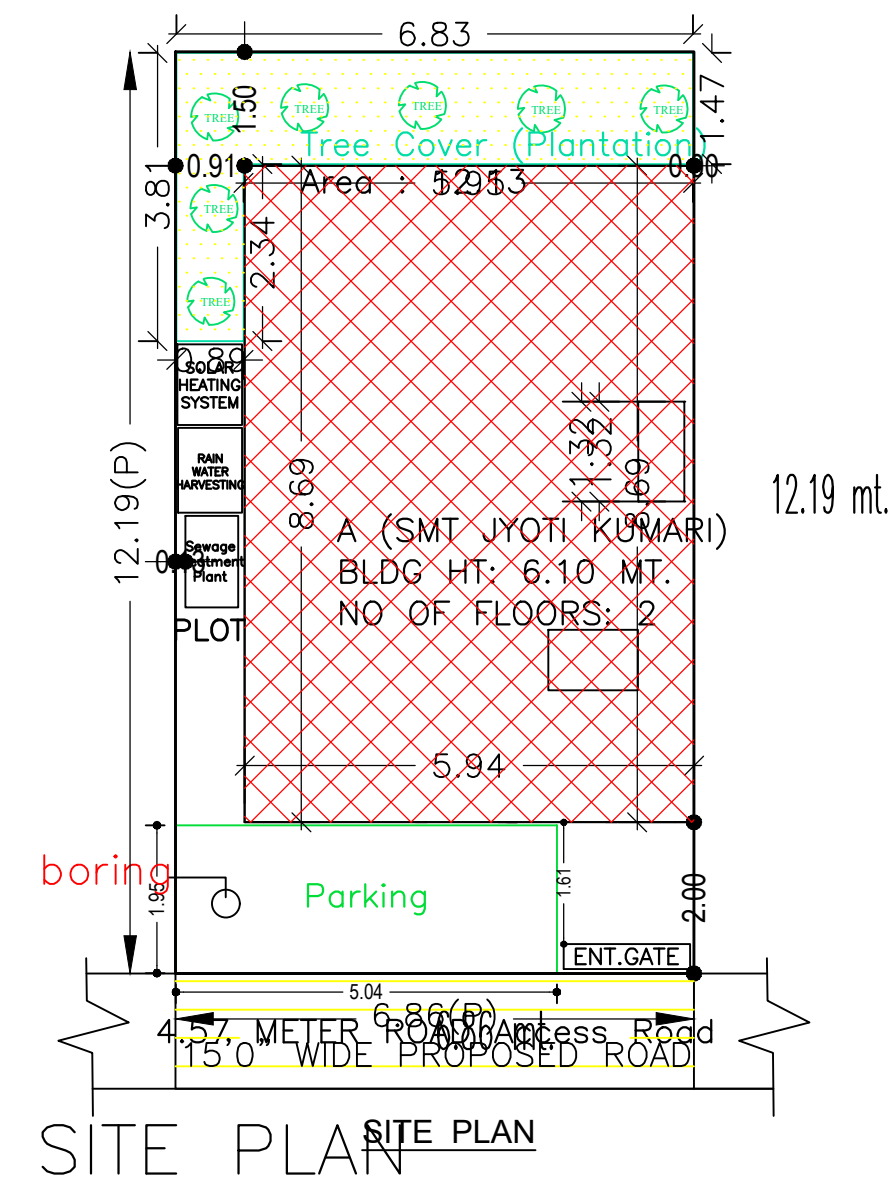

AREA STATEMENT	VERSION NO.: 1.0.64
MADHUPUR NAGAR PARISHAD	VERSION DATE: 16/10/2020
PROJECT DETAIL:	
Region: JHARKHAND URBAN LOCAL BODIES	Plot Use: Residential
District: DEOGHAR	Plot SubUse: Bungalow/ Dwelling / Non Apartment
Authority: MADHUPUR NAGAR PARISHAD	PlotNearbyReligiousStructure: NA
Inward No: MNP/BP/0064/W02/2022	Plot/SubPlot No: 1/33A & 1/33
Application Type: General Proposal	North: Road Width - 4.57 WIDE PROPOSED ROAD
Project Type: Building Permission	South: Plot No. - LAND OF KAMAKHYA PRASAD HOR
Nature of Development: New	East: Plot No. - HOUSE OF SATYENDRA DUTT
Location of Development Area: Old Area	West: Plot No. - VENDORS LAND
AREA DETAILS:	
AREA OF PLOT (Minimum)	(A) 83.60
NET AREA OF PLOT(Gross Plot Area - Deduction from Gross Plot area)	(A-Deductions) 83.60
Deduction for Balance Plot Area(from Gross Plot Area)	
Common Plot	12.13
Total	12.13
BALANCE AREA OF PLOT(Net Plot Area - Recreational/Amenity space)	(A-Deductions) 71.47
PLOT AREA FOR COVERAGE(Net Plot Area)	(A-Deductions) 83.60
Plot Area for FAR (Net Plot Area + Road Widening Area)	(A-Deductions) 83.60
COVERAGE CHECK	
Permissible Coverage area (70.00 %)	58.52
Proposed Coverage Area (60.80 %)	50.83
Total Prop. Coverage Area (60.8 %)	50.83
Balance coverage area (9.20 %)	7.69
FAR CHECK	
Perm. FAR Area (1.500)	125.40
Total Perm. FAR area	125.40
Residential FAR	101.65
Proposed FAR Area	101.65
Total Proposed FAR Area	101.65
Consumed FAR (Factor)	1.22
Balance FAR Area	23.75
BUILT UP AREA CHECK	
Total Proposed BuiltUp Area	101.66
ARCHITECT (Regd)	SHANKAR PRASAD SINGH
ENGINEER (Regd)	
SUPERVISOR (Regd)	
OWNER (Regd)	SMT. JYOTI KUMARI
DEVELOPMENT AUTHORITY	
	LOCAL BODY

FAR & Tenement Details (Table 4c-1)

Building	No. of Same Bldg	Gross Built Up Area (Sq.mt.)	Deductions From Gross BUA(Area in Sq.mt.) Cutout	Total Built Up Area (Sq.mt.)	Proposed FAR Area (Sq.mt.)		Total Consumed FAR Area (Sq.mt.)	Trmt (No.)
					Resi.	Total FAR Area (Sq.mt.)		
A (SMT JYOTI KUMARI)	1	103.28	1.62	101.66	101.66	101.66	101.66	01
Grand Total :	1	103.28	1.62	101.66	101.66	101.66	101.66	01

Building USE/SUBUSE Details

Building Name	Building Use	Building SubUse	Building Structure
A (SMT JYOTI KUMARI)	Residential	Bungalow/ Dwelling / Non Apartment	Non-Highrise

Buildingwise Floor FAR Details

Floor Name	Building Name		Total	
	Proposed Built Up Area (Sq.mt.)	Proposed FAR Area (Sq.mt.)	Total Proposed Built Up Area (Sq.mt.)	Total FAR Area (Sq.mt.)
Ground Floor	50.83	50.83	50.83	50.83
First Floor	50.83	50.83	50.83	50.83
Terrace Floor	0.00	0.00	0.00	0.00
Total :	101.66	101.66	101.66	101.66

COLOR INDEX	
PLOT BOUNDARY	Black
ABUTTING ROAD	Green
PROPOSED CONSTRUCTION	Red
COMMON PLOT	Yellow
ROAD WIDENING AREA	Blue
EXISTING (To be retained)	Blue
EXISTING (To be demolished)	Yellow

LTP NAME AND SIGNATURE	STRUCTURAL ENG'S NAME AND SIGNATURE	BUILDER NAME AND SIGNATURE	DIGITAL SIGNATURE
SHANKAR PRASAD SINGH MNP/ENG/0005/2018			

Proposal Basic Information

Proposal File No.	MNP/IBP/0064/W02/2022
Owner Name	SMT. JYOTI KUMARI
Khata No	1/33A & 1/33
Plot No	1/33A & 1/33
Village Name	Sapha
Use	Residential
SubUse	Bungalow/ Dwelling / Non Apartment

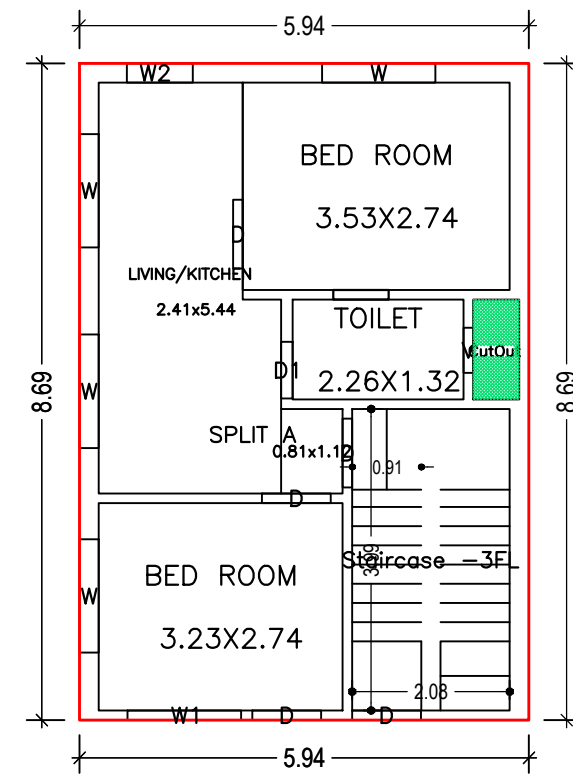

GROUND FLOOR PLAN (Proposed)
(SCALE 1:100)

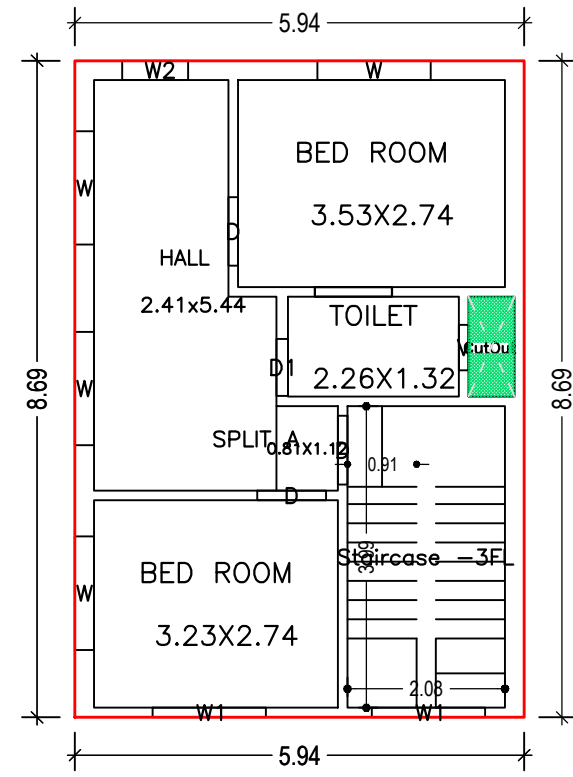

FIRST FLOOR PLAN (Proposed)
(SCALE 1:100)

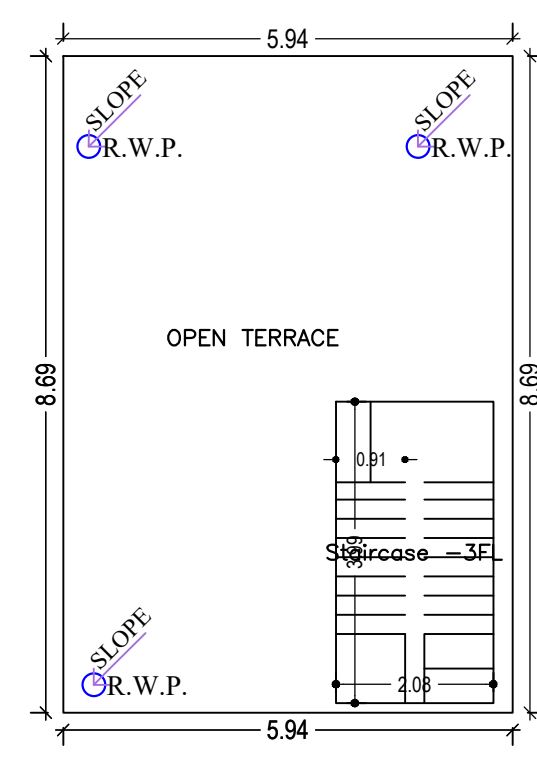

TERRACE FLOOR PLAN (SCALE 1:100)

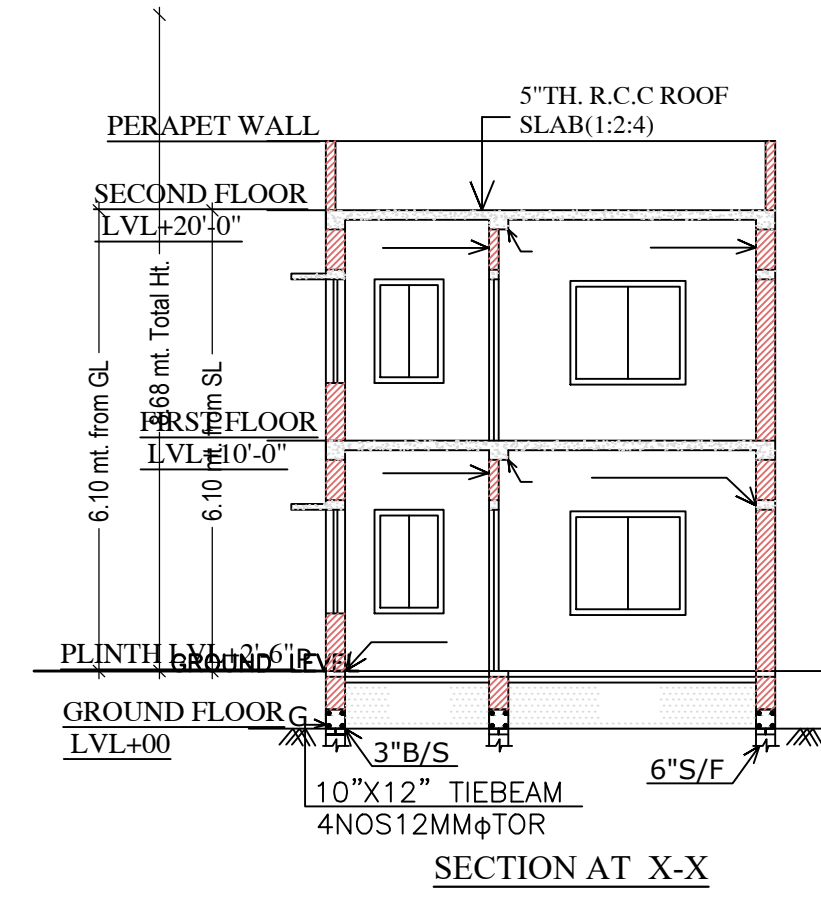

SECTION AT X-X

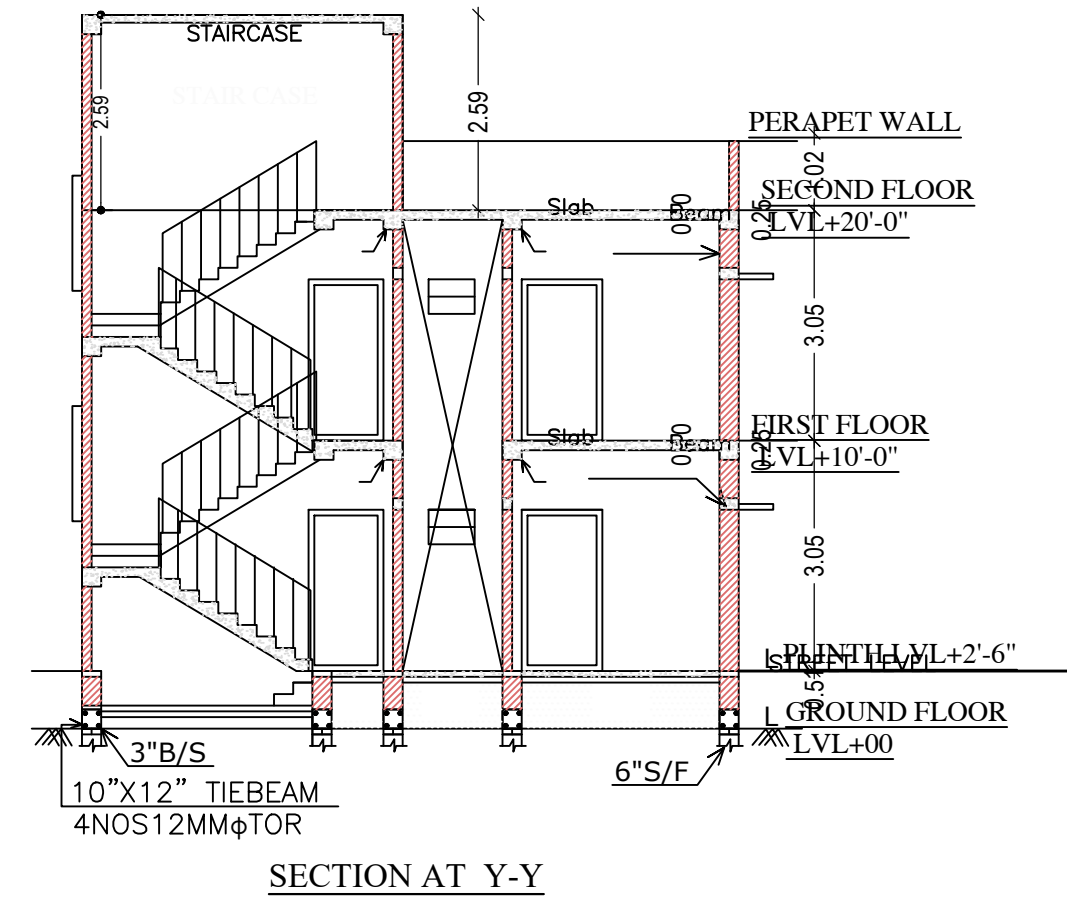

SECTION AT Y-Y

UnitBUA Table for Building :A (SMT JYOTI KUMARI)

FLOOR	Name	UnitBUA Type	UnitBUA Area	Carpet Area	No. of Rooms	No. of Tenement
GROUND FLOOR PLAN	SPLIT A	FLAT	70.34	70.12	4	1
FIRST FLOOR PLAN	SPLIT A	FLAT	0.00	0.00	4	0
Total:	-	-	70.34	70.12	8	1

SCHEDULE OF DOOR:

BUILDING NAME	NAME	LENGTH	HEIGHT	NOS
A (SMT JYOTI KUMARI)	D1	0.75	2.13	02
A (SMT JYOTI KUMARI)	D	0.91	2.13	07

SCHEDULE OF WINDOW/VENTILATION:

BUILDING NAME	NAME	LENGTH	HEIGHT	NOS
A (SMT JYOTI KUMARI)	V	0.60	2.70	02
A (SMT JYOTI KUMARI)	W2	0.87	2.70	02
A (SMT JYOTI KUMARI)	W	1.50	2.70	08
A (SMT JYOTI KUMARI)	W1	1.50	2.70	03

Building :A (SMT JYOTI KUMARI)

Floor Name	Gross Builtup Area	Deductions From Gross BUA(Area in Sq.mt.)	Total Built Up Area (Sq.mt.)	Proposed FAR Area (Sq.mt.)	Total FAR Area (Sq.mt.)	Total Consumed Additional FAR Area (Sq.mt.)	Trmt (No.)
Ground Floor	51.64	0.81	50.83	50.83	50.83	50.83	01
First Floor	51.64	0.81	50.83	50.83	50.83	50.83	00
Terrace Floor	0.00	0.00	0.00	0.00	0.00	0.00	00
Total:	103.28	1.62	101.66	101.66	101.66	101.66	01
Total Number of Same Buildings :	1						
Total :	103.28	1.62	101.66	101.66	101.66	101.66	01

LTP NAME AND SIGNATURE	STRUCTURAL ENG'S NAME AND SIGNATURE	BUILDER NAME AND SIGNATURE	DIGITAL SIGNATURE
SHANKAR PRASAD SINGH MNP/ENG/0005/2018			

Proposal Basic Information

Proposal File No.	MNP/EP/0064/W02/2022
Owner Name	SMT. JYOTI KUMARI
Khata No	1/33A & 1/33
Plot No	1/33A & 1/33
Village Name	Sapha
Use	Residential
SubUse	Bungalow/ Dwelling / Non Apartment

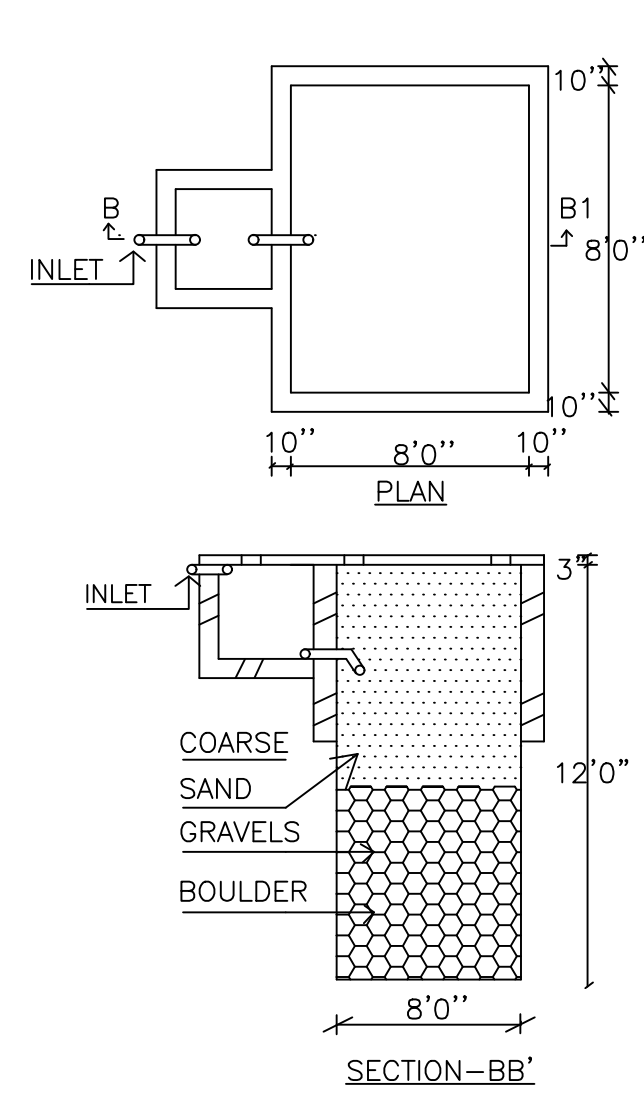

RAIN WATER HARVESTING SCHEME

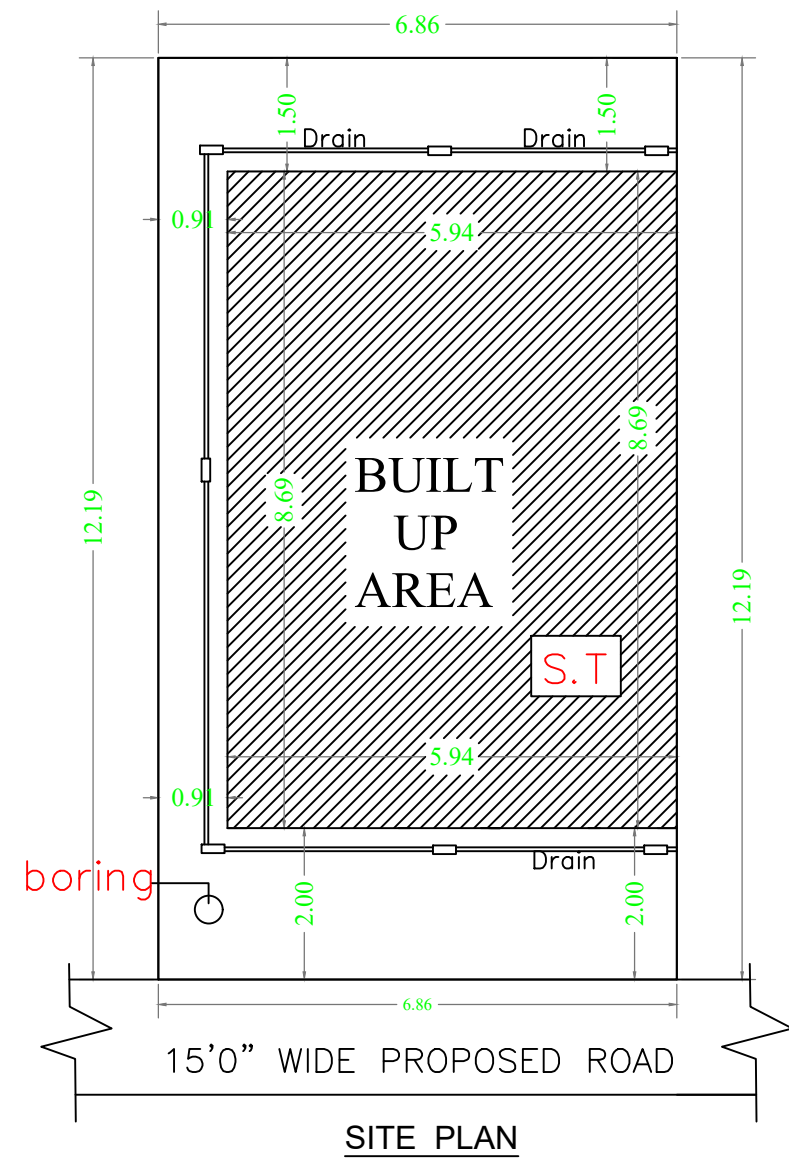
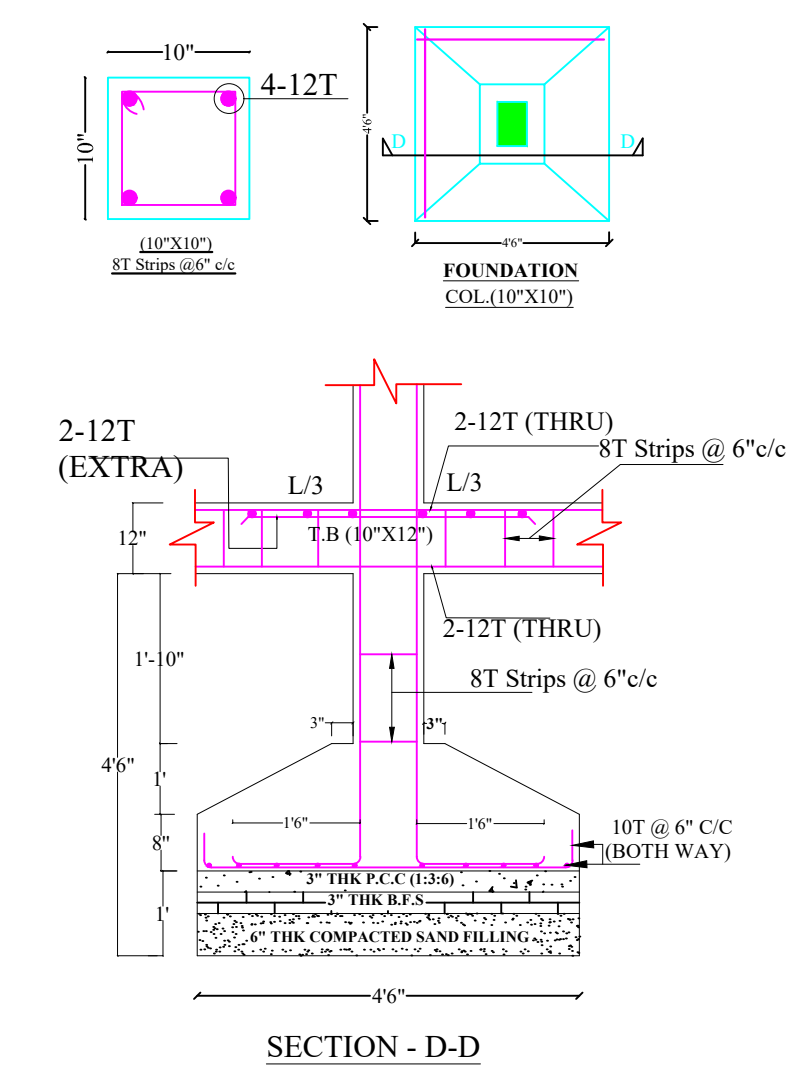
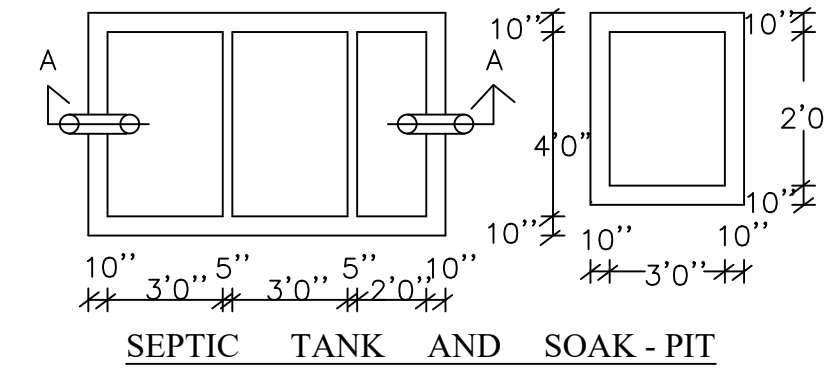
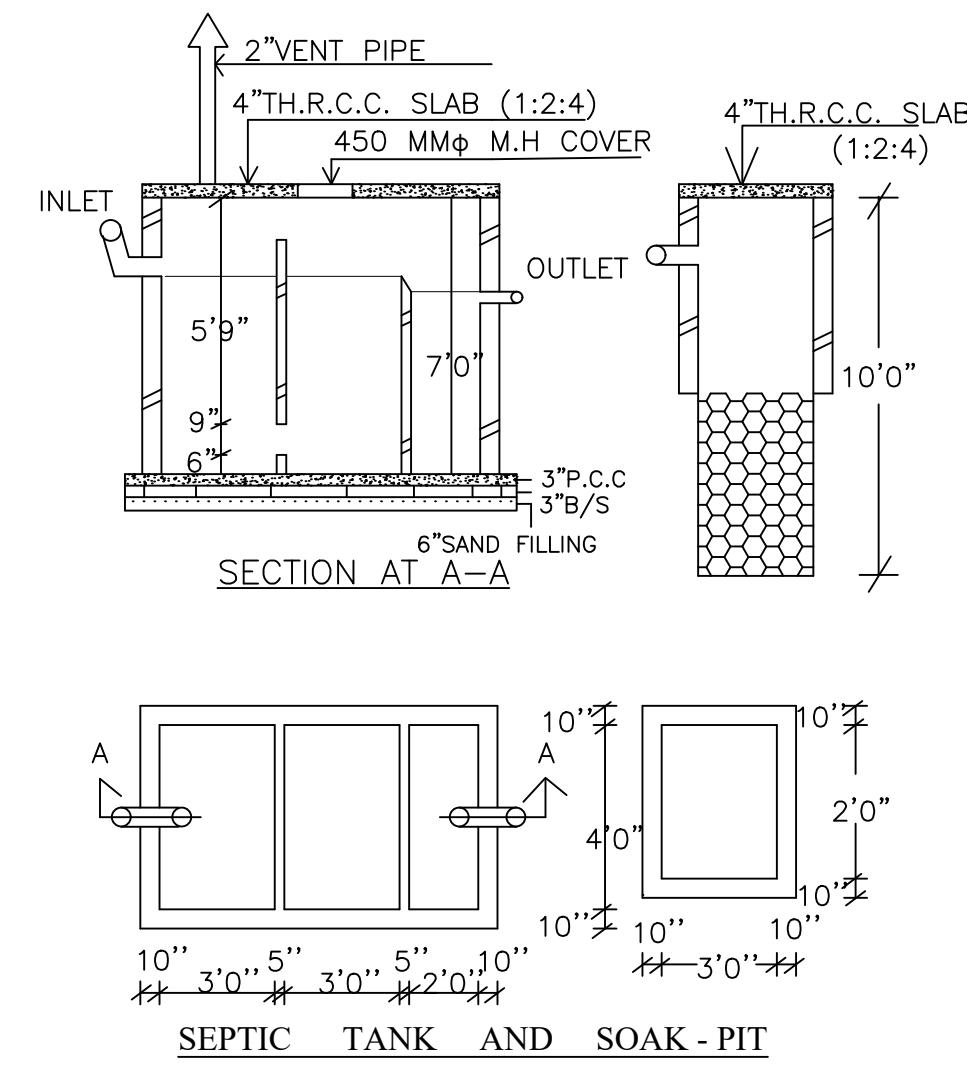
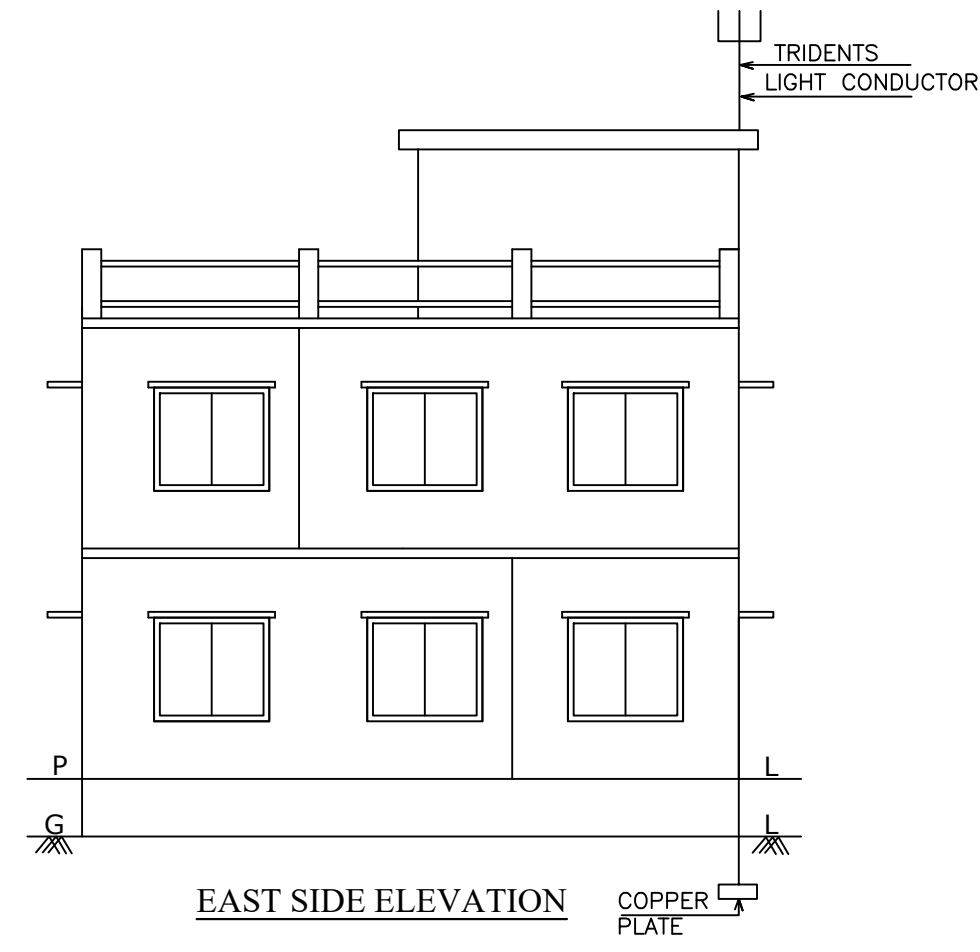
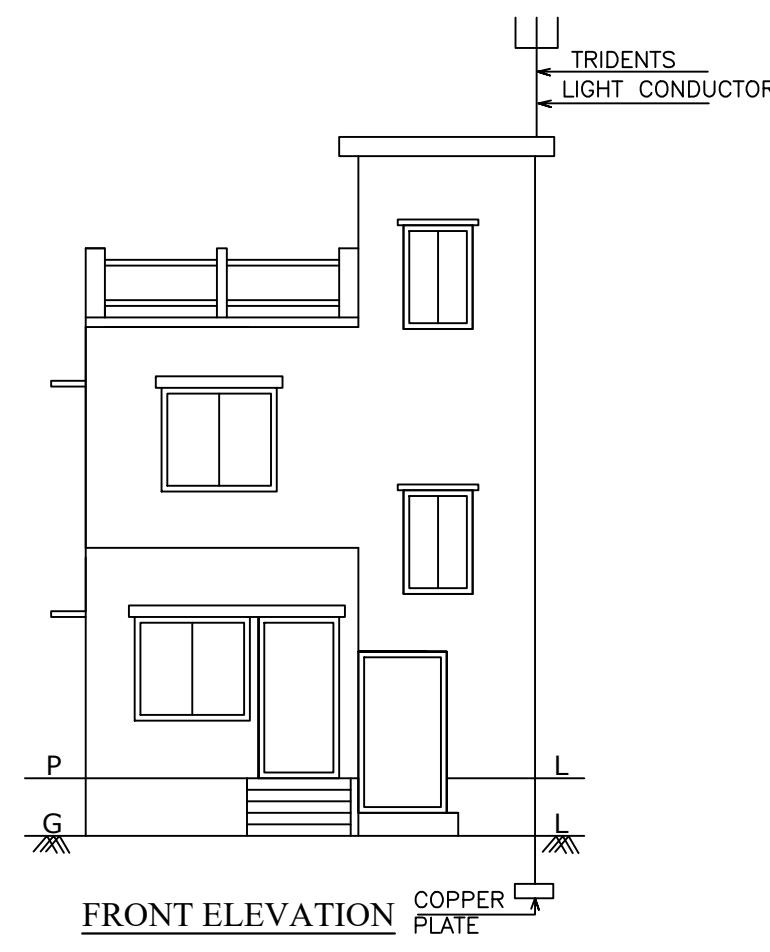

LTP NAME AND SIGNATURE	STRUCTURAL ENG'S NAME AND SIGNATURE	BUILDER NAME AND SIGNATURE	DIGITAL SIGNATURE
SHANKAR PRASAD SINGH MNP/ENG/0005/2018			