

Proposal Basic Information	
Proposal File No.	MNP/EP/0005/W21/2023
Owner Name	DHARMENDRA KUMAR GUPTA AND RINKU DEVI
Khata No	220/1/SHA
Plot No	0/1
Village Name	Patharchptti
Use	Residential
SubUse	Bungalow/ Dwelling / Non Apartment

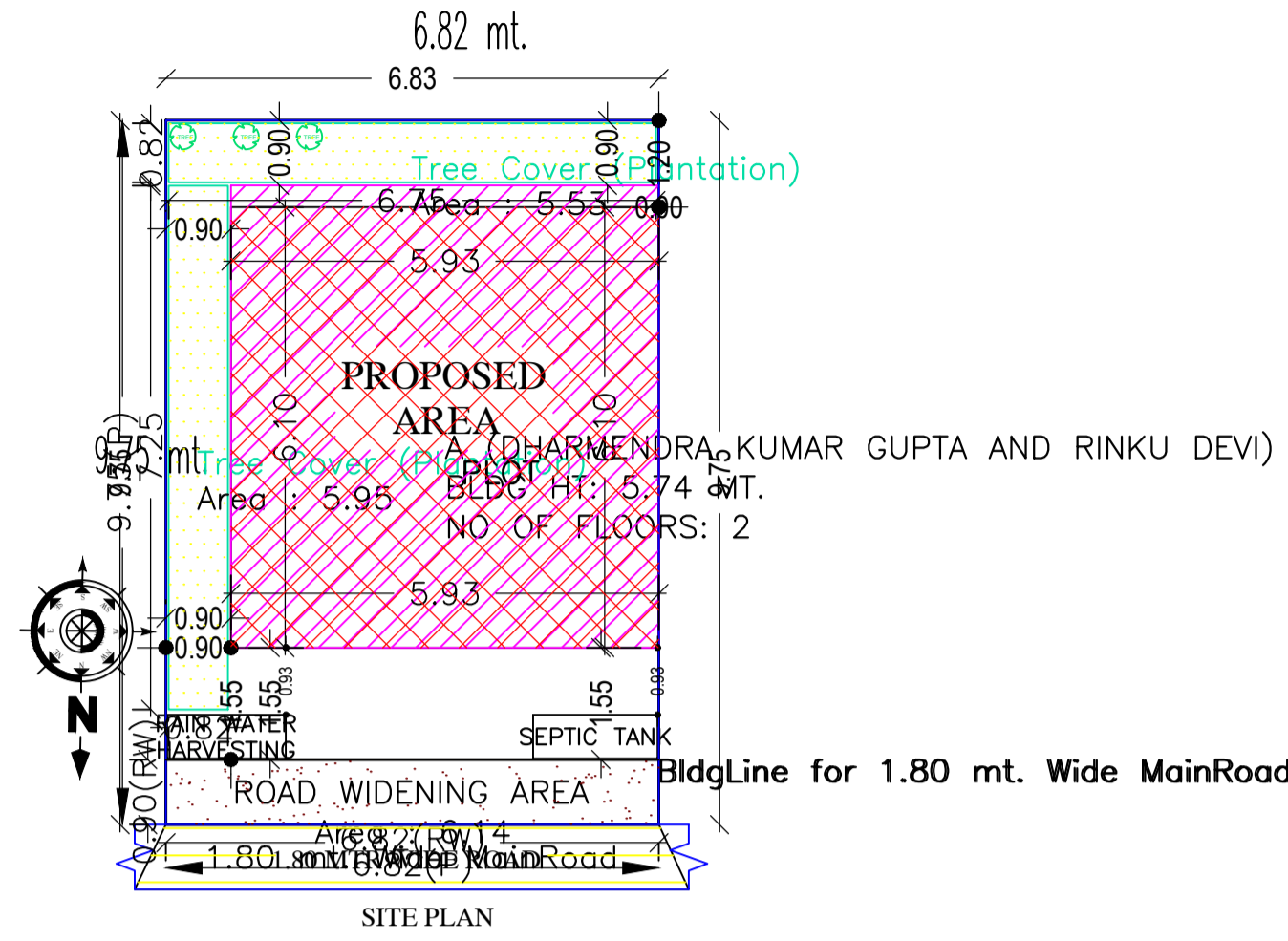

SITE PLAN

AREA STATEMENT MADHUPUR NAGAR PARISHAD	VERSION NO.: 1.0.66 VERSION DATE: 16/10/2020
PROJECT DETAIL:	
Region: JHARKHAND URBAN LOCAL BODIES	Plot Use: Residential
District: DEOGHAR	Plot SubUse: Bungalow/ Dwelling / Non Apartment
Authority: MADHUPUR NAGAR PARISHAD	PlotNearbyReligiousStructure: NA
Inward_No: MNP/EP/0005/W21/2023	PlotSubPlot No: 0/1
Application Type: General Proposal	North: Road Width - 1.8
Project Type: Building Permission	South: Plot No. - LAND OF B.N TIWARI
Nature of Development: New	East: Plot No. - SUB PLOT N0- B
Location of Development Area: Old Area	West: Plot No. - VENDORS LAND
AREA DETAILS: SQ.MT.	
AREA OF PLOT (Minimum)	(A) 66.54
Deduction for NetPlot Area	
Road Widening Area	6.14
Total	6.14
NET AREA OF PLOT(Gross Plot Area - Deduction from Gross Plot area)	(A-Deductions) 60.40
Deduction for Balance Plot Area(from Gross Plot Area)	
Road Widening Area	6.14
Common Plot	11.48
Total	17.62
BALANCE AREA OF PLOT(Net Plot Area - Recreational/Amenity space)	(A-Deductions) 48.92
PLOT AREA FOR COVERAGE(Net Plot Area)	(A-Deductions) 60.40
Plot Area for FAR (Net Plot Area + RoadWidening Area)	(A-Deductions) 60.40
COVERAGE CHECK	
Permissible Coverage area (70.00 %)	42.28
Proposed Coverage Area (59.83 %)	36.14
Total Prop. Coverage Area (59.83 %)	36.14
Balance coverage area (10.17 %)	6.14
FAR CHECK	
Perm. FAR Area (1,200)	72.48
Total Perm. FAR area	72.48
Residential FAR	72.29
Proposed FAR Area	72.29
Total Proposed FAR Area	72.29
Consumed FAR (Factor)	1.20
Balance FAR Area	0.19
BUILT UP AREA CHECK	
Total Proposed BuiltUp Area	72.28
ARCHITECT (Regd)	PRAWEEEN KUMAR MAHTO
ENGINEER (Regd)	
SUPERVISOR (Regd)	
OWNER (Regd)	DHARMENDRA KUMAR GUPTA AND RINKU DEVI
DEVELOPMENT AUTHORITY	LOCAL BODY

Building USE/SUBUSE Details

Building Name	Building Use	Building SubUse	Building Structure
A (DHARMENDRA KUMAR GUPTA AND RINKU DEVI)	Residential	Bungalow/ Dwelling / Non Apartment	Non-Highrise

FAR & Tenement Details (Table 4c-1)

Building	No. of Same Bldg	Total Built Up Area (Sq.mt.)	Proposed FAR Area (Sq.mt.) Resi.	Total FAR Area (Sq.mt.)	Total Consumed Additional FAR Area (Sq.mt.)	Tnmt (No.)
A (DHARMENDRA KUMAR GUPTA AND RINKU DEVI)	1	72.28	72.28	72.28	72.28	01
Grand Total :	1	72.28	72.28	72.28	72.28	01

Buildingwise Floor FAR Details

Floor Name	Building Name A (DHARMENDRA KUMAR GUPTA AND RINKU DEVI)		Total	
	Proposed Built Up Area (Sq.mt.)	Proposed FAR Area (Sq.mt.)	Total Proposed Built Up Area (Sq.mt.)	Total FAR Area (Sq.mt.)
Ground Floor	36.14	36.14	36.14	36.14
First Floor	36.14	36.14	36.14	36.14
Terrace Floor	0.00	0.00	0.00	0.00
Total :	72.28	72.28	72.28	72.28

COLOR INDEX	
PLOT BOUNDARY	Black
ABUTTING ROAD	Green
PROPOSED CONSTRUCTION	Red
COMMON PLOT	Yellow
ROAD WIDENING AREA	Yellow
EXISTING (To be retained)	Blue
EXISTING (To be demolished)	Yellow

LTP NAME AND SIGNATURE	STRUCTURAL ENG'S NAME AND SIGNATURE	BUILDER NAME AND SIGNATURE	DIGITAL SIGNATURE
PRAWEEEN KUMAR MAHTO MNP/ENG/0005/2020			

Proposal Basic Information	
Proposal File No.	MNP/ENG/0005/W21/2023
Owner Name	DHARMENDRA KUMAR GUPTA AND RINKU DEVI
Khata No	220/1/SHA
Plot No	0/1
Village Name	Patharchptti
Use	Residential
SubUse	Bungalow/ Dwelling / Non Apartment

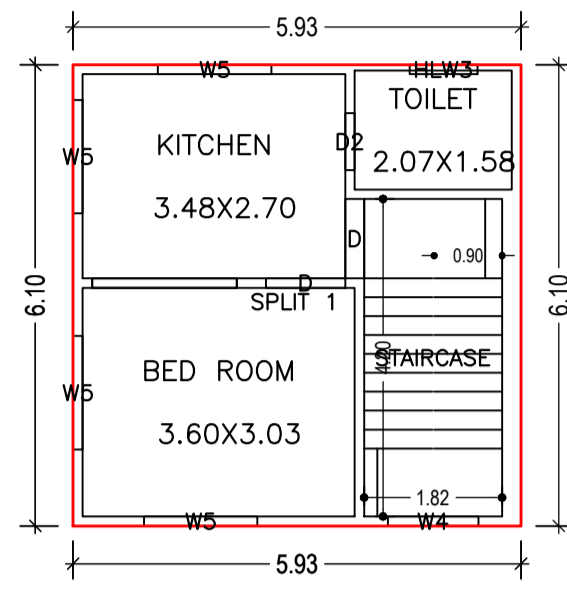

FIRST FLOOR PLAN
(Proposed)
(SCALE 1:100)

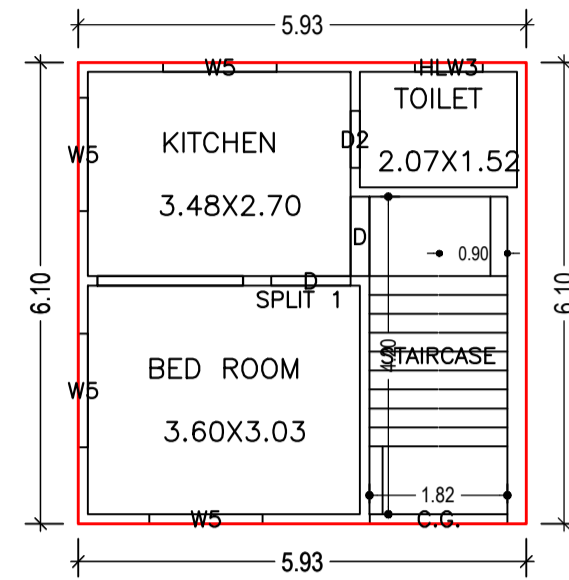

GROUND FLOOR PLAN
(Proposed)
(SCALE 1:100)

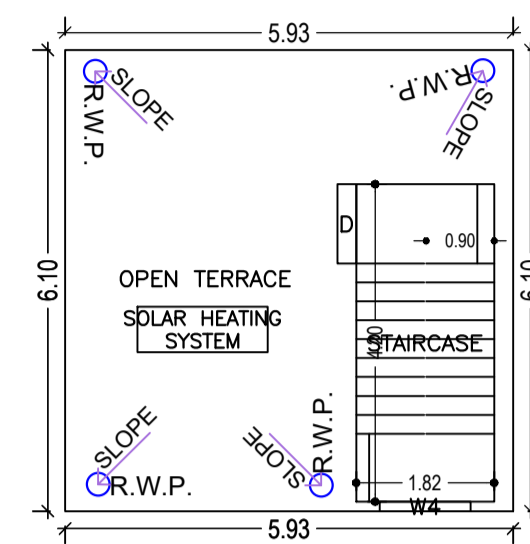

TERRACE FLOOR PLAN
(SCALE 1:100)

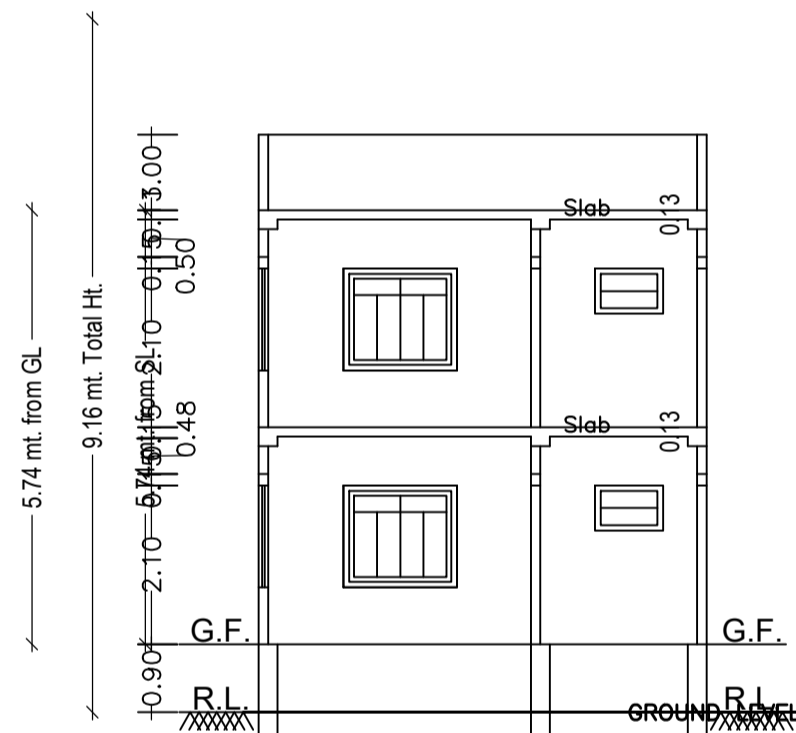

SECTION ON A-A

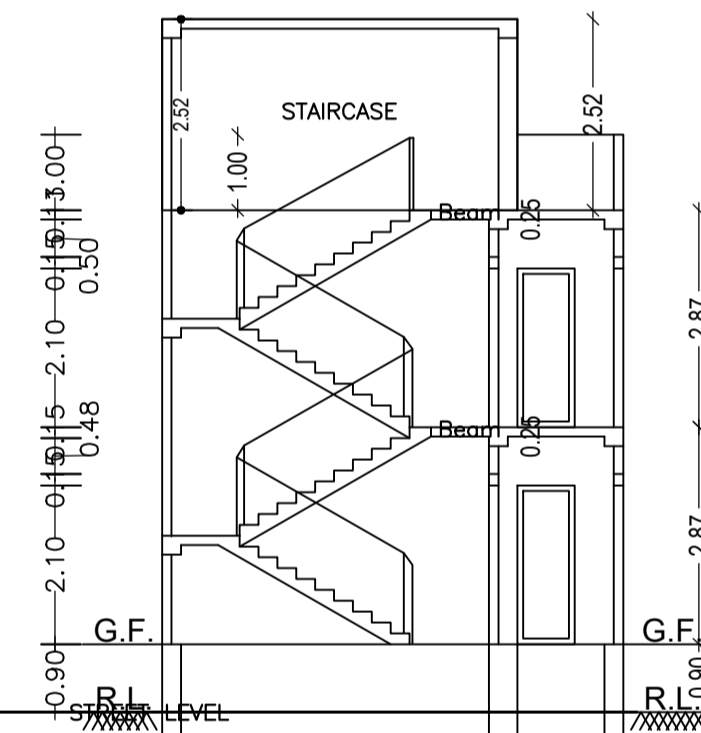

SECTION ON B-B

SCHEDULE OF DOOR:

BUILDING NAME	NAME	LENGTH	HEIGHT	NOS
A (DHARMENDRA KUMAR GUPTA AND RINKU DEVI)	D2	0.75	2.10	02
A (DHARMENDRA KUMAR GUPTA AND RINKU DEVI)	D	1.05	2.10	04

SCHEDULE OF WINDOW/VENTILATION:

BUILDING NAME	NAME	LENGTH	HEIGHT	NOS
A (DHARMENDRA KUMAR GUPTA AND RINKU DEVI)	HLW3	0.90	0.60	02
A (DHARMENDRA KUMAR GUPTA AND RINKU DEVI)	W4	1.20	1.35	02
A (DHARMENDRA KUMAR GUPTA AND RINKU DEVI)	W5	1.50	1.35	08

UnitBUA Table for Building :A (DHARMENDRA KUMAR GUPTA AND RINKU DEVI)

FLOOR	Name	UnitBUA Type	UnitBUA Area	Carpet Area	No. of Rooms	No. of Tenement
FIRST FLOOR PLAN	SPLIT 1	FLAT	0.00	0.00	3	0
GROUND FLOOR PLAN	SPLIT 1	FLAT	54.34	53.86	3	1
Total:	-	-	54.34	53.86	6	1

Building :A (DHARMENDRA KUMAR GUPTA AND RINKU DEVI)

Floor Name	Total Built Up Area (Sq.mt.)	Proposed FAR Area (Sq.mt.) Resi.	Total FAR Area (Sq.mt.)	Total Consumed Additional FAR Area (Sq.mt.)	Tnmt (No.)
Ground Floor	36.14	36.14	36.14	36.14	01
First Floor	36.14	36.14	36.14	36.14	00
Terrace Floor	0.00	0.00	0.00	0.00	00
Total:	72.28	72.28	72.28	72.28	01
Total Number of Same Buildings :	1				
Total :	72.28	72.28	72.28	72.28	01

LTP NAME AND SIGNATURE	STRUCTURAL ENG'S NAME AND SIGNATURE	BUILDER NAME AND SIGNATURE	DIGITAL SIGNATURE
PRAWEEEN KUMAR MAHTO MNP/ENG/0005/2020			

Proposal Basic Information	
Proposal File No.	MNP/ENG/0005/W21/2023
Owner Name	DHARMENDRA KUMAR GUPTA AND RINKU DEVI
Khata No	220/1/SHA
Plot No	0/1
Village Name	Patharchptti
Use	Residential
SubUse	Bungalow/ Dwelling / Non Apartment

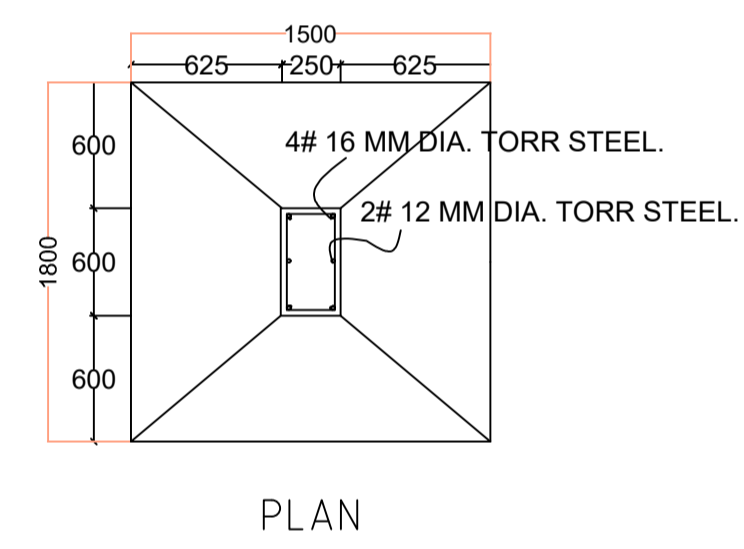
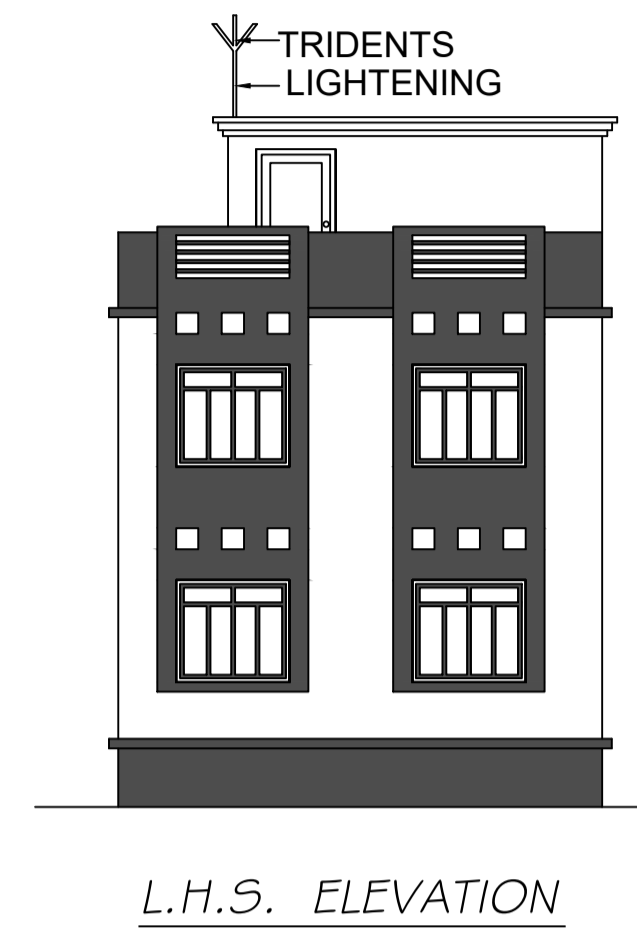
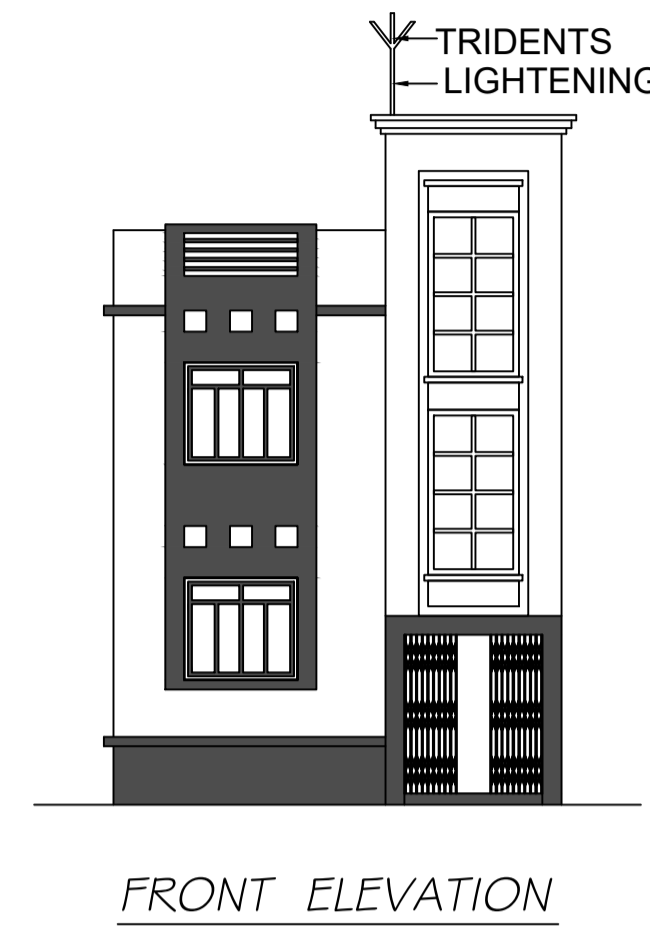
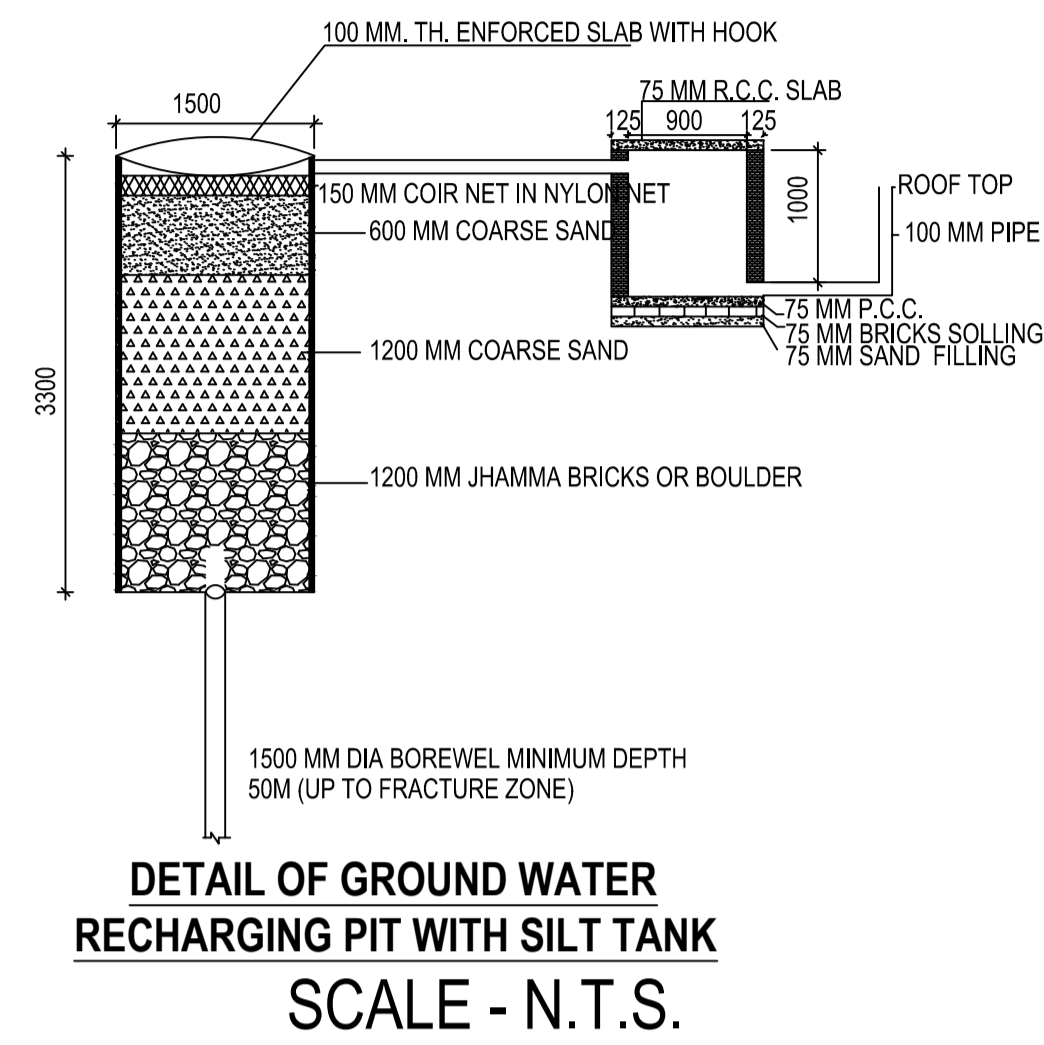
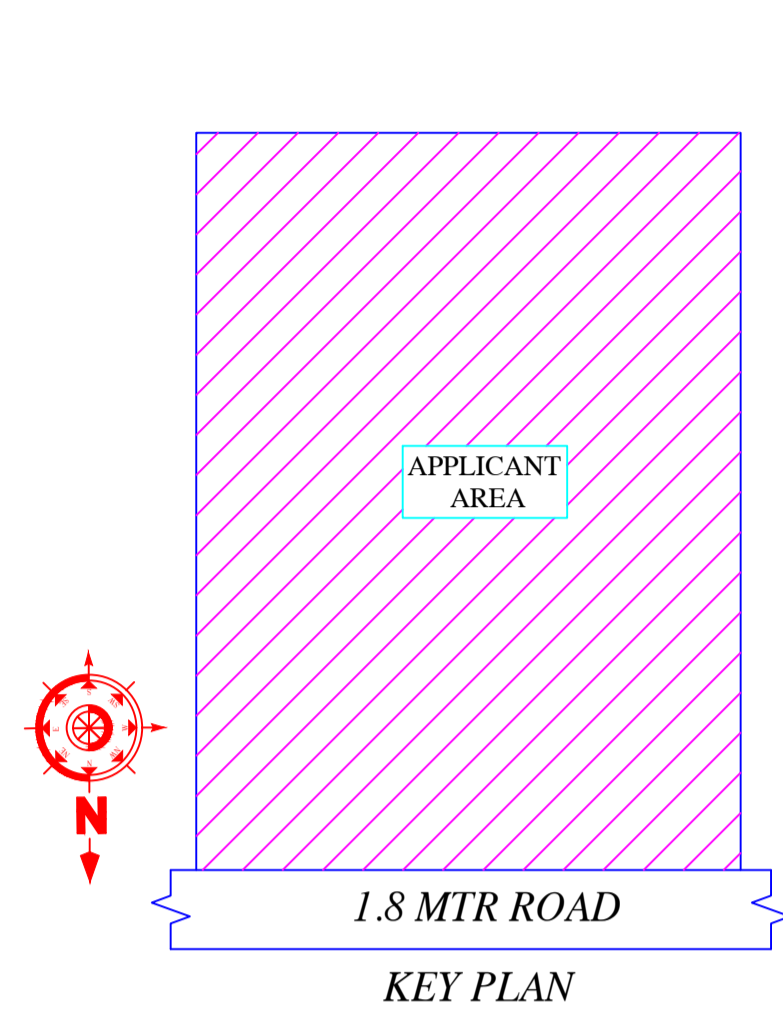

FOUNDATION DETAILS (ISOLATED R.C.C FOOTING)

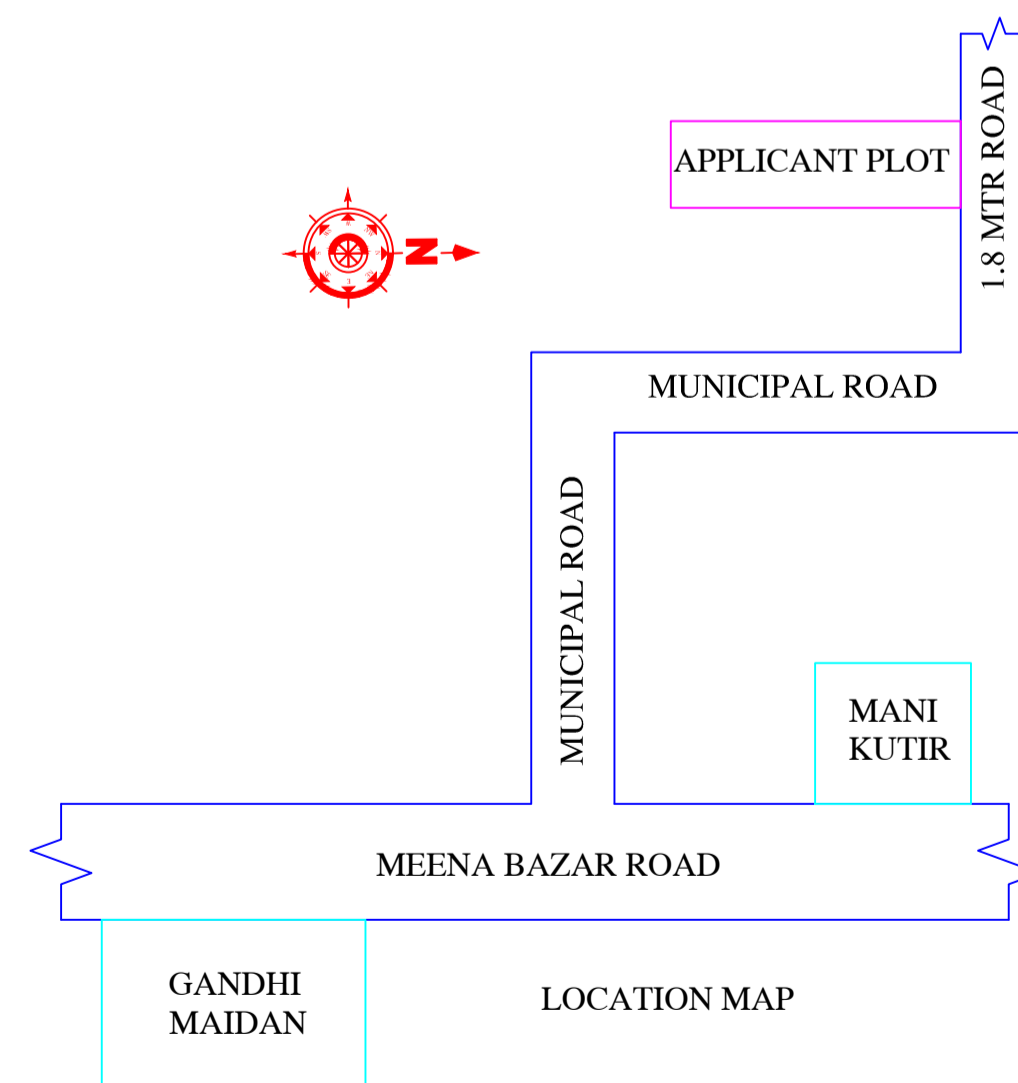
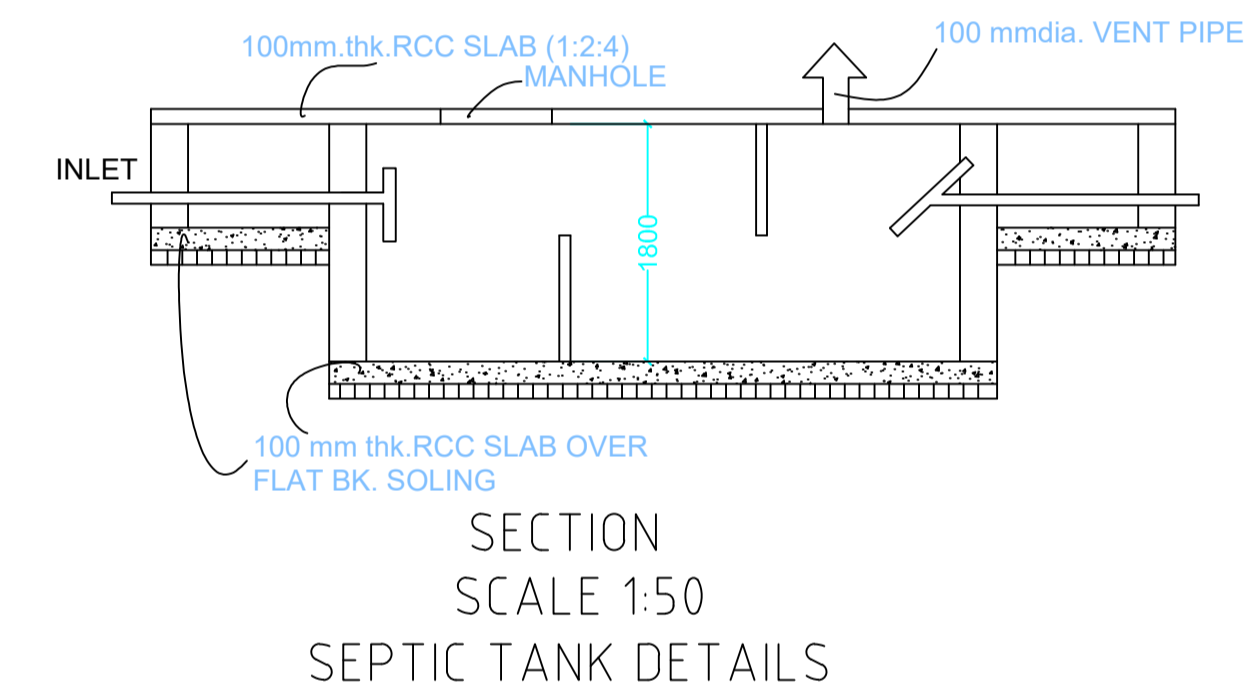
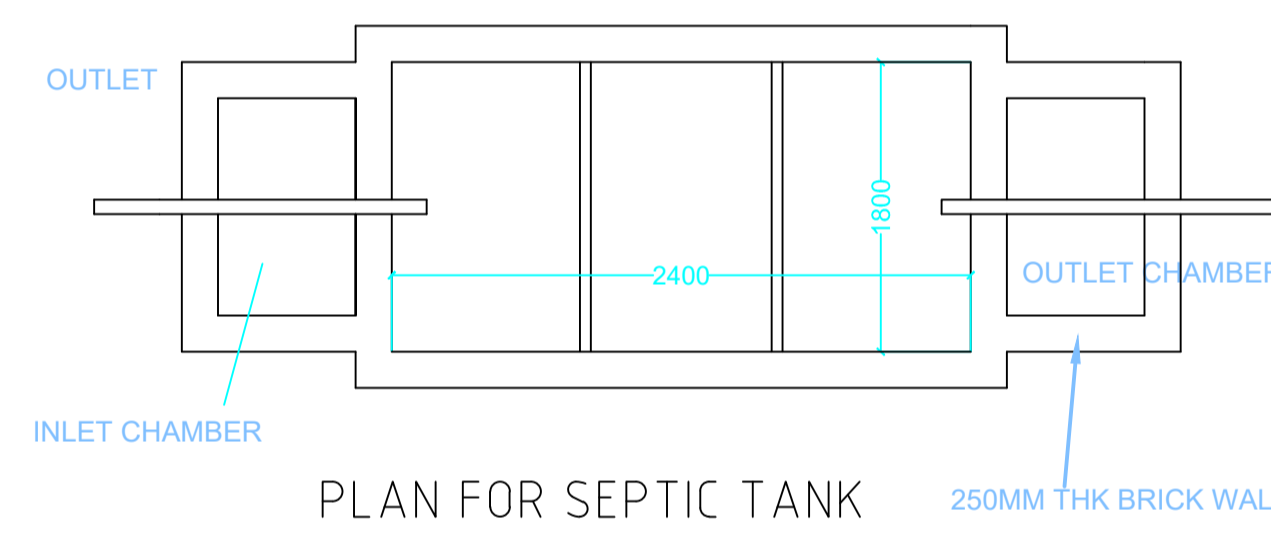
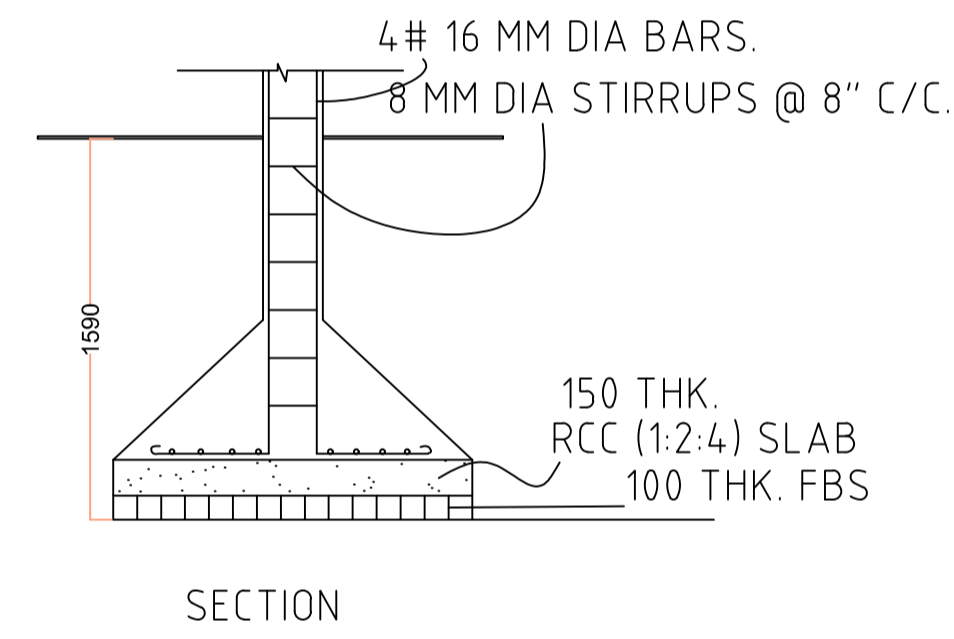

This is certify that the structure design is in accordance with the latest I-S code(I-S 875,I-S456-2002, I-S 1893-2000) for design & loading conditions (Sessmic/wind/dead/live) and other all parameters are taken in account for safetyof the structure.

LTP NAME AND SIGNATURE	STRUCTURAL ENG'S NAME AND SIGNATURE	BUILDER NAME AND SIGNATURE	DIGITAL SIGNATURE
PRAWEEEN KUMAR MAHTO MNP/ENG/0005/2020			