

Project Title :PROPOSED G+2 STORIED R.C.C. RESIDENTIAL BUILDING FOR SURENDRA KUMAR GUTGUTIA, SHUBHOM GUTGUTIA AND SANCHET GUTGUTIA

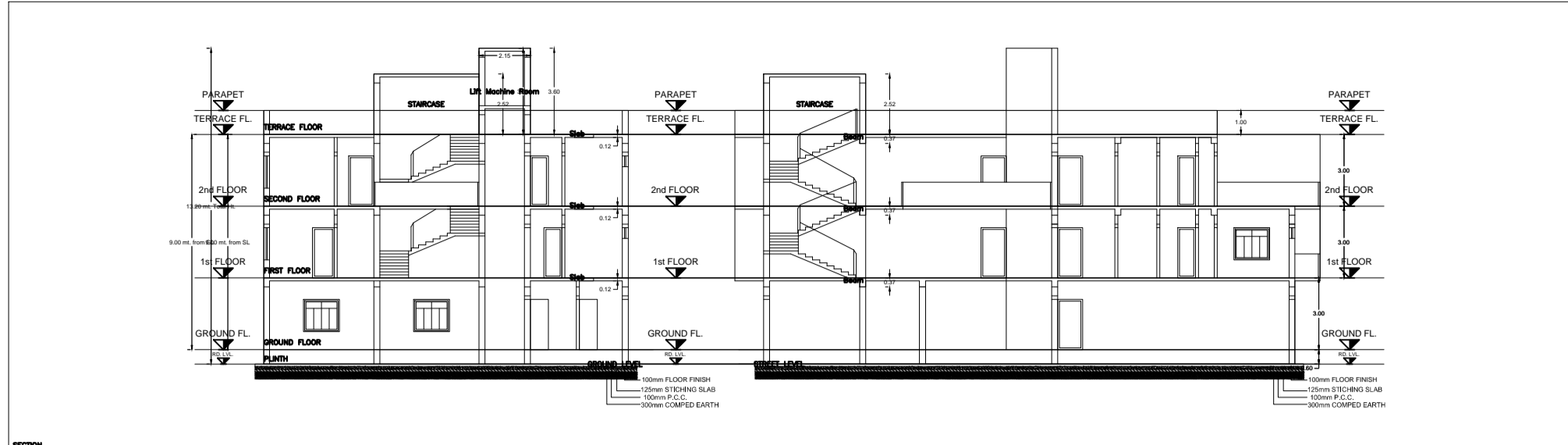

This is certify that the structure design is in accordance with the latest I-S code(I-S 8751-5456-2002, I-S 1893-2000) for design & loading conditions (Seismic/Wind/Load/Live) and other all parameters are taken in account for safety of the structure.

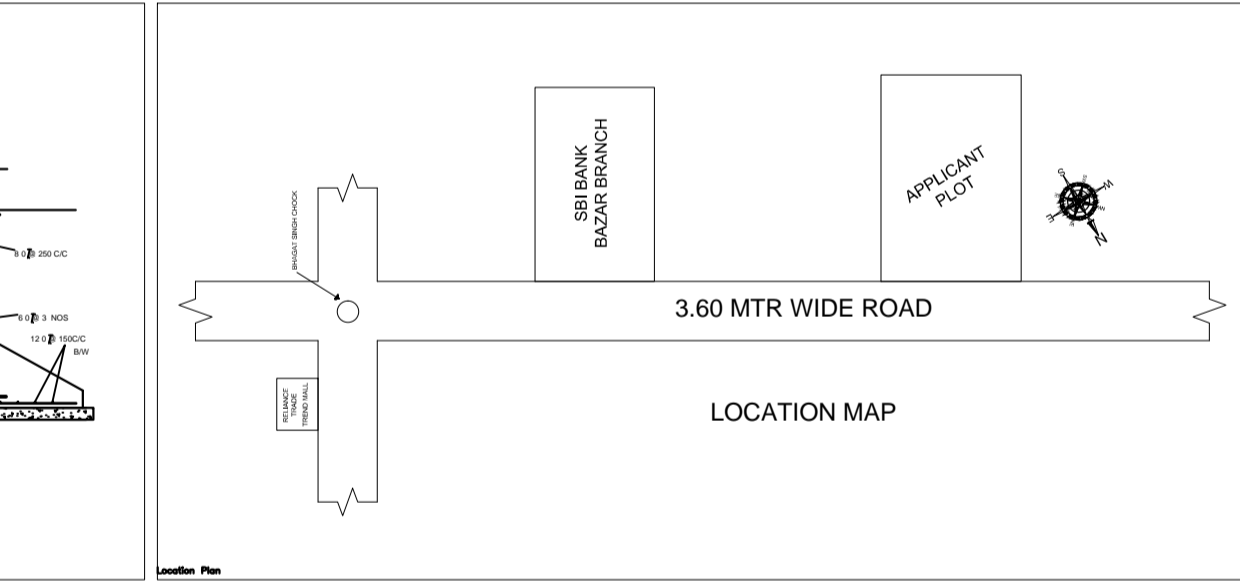
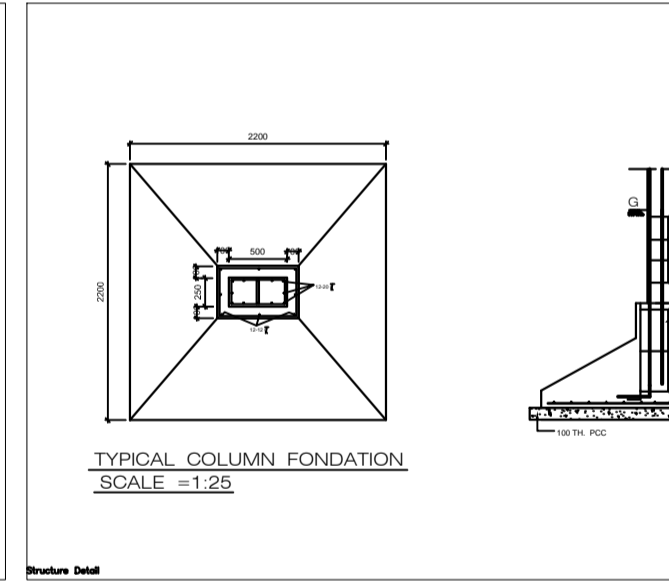
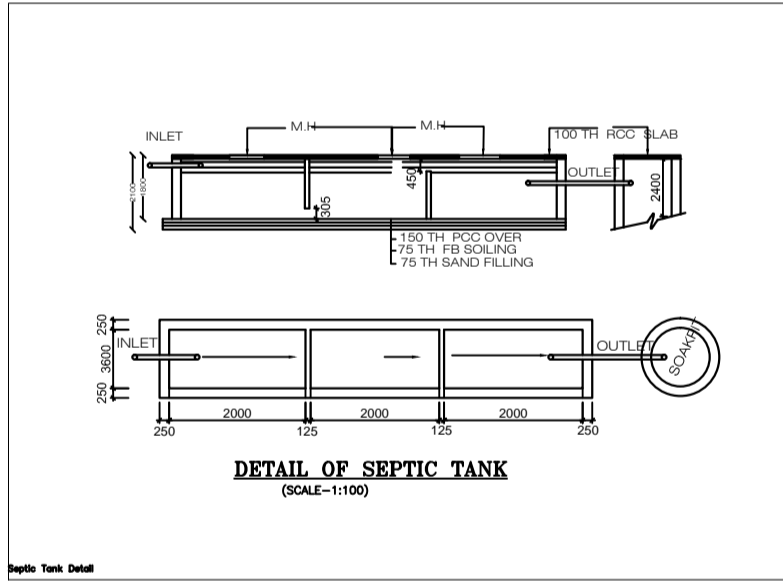
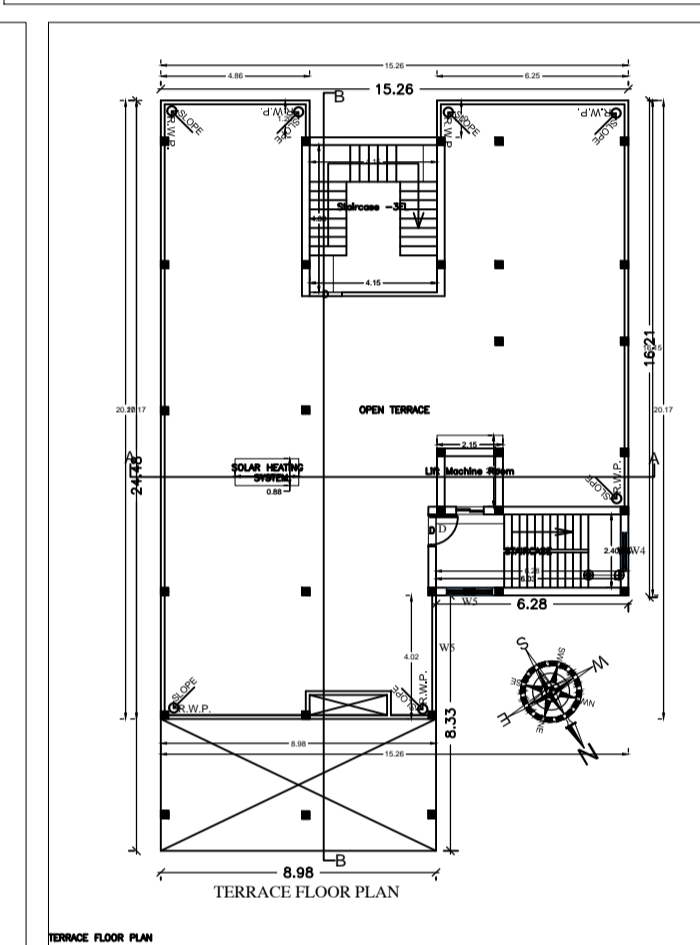
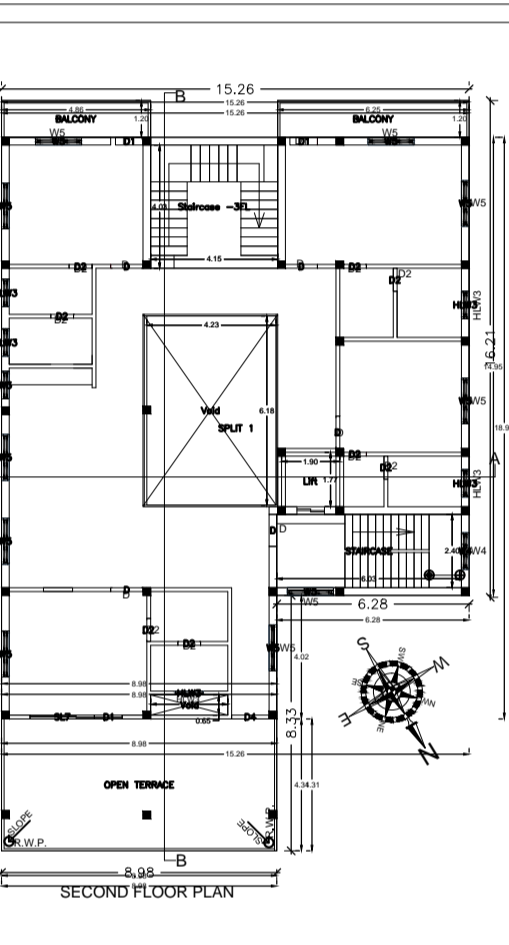
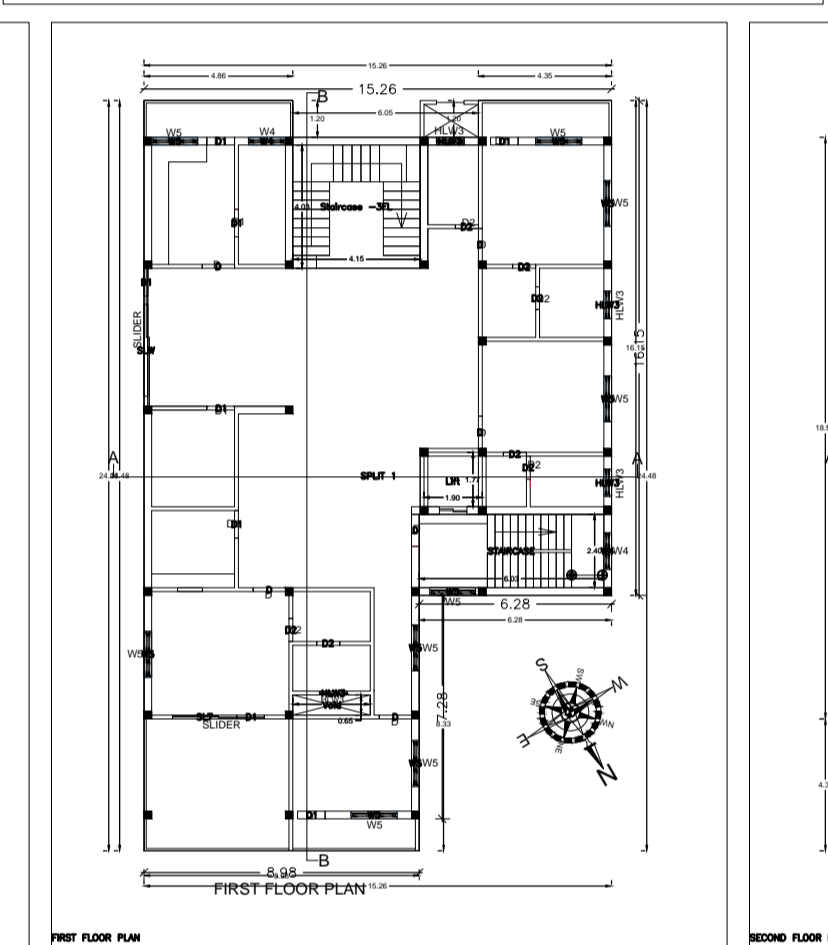
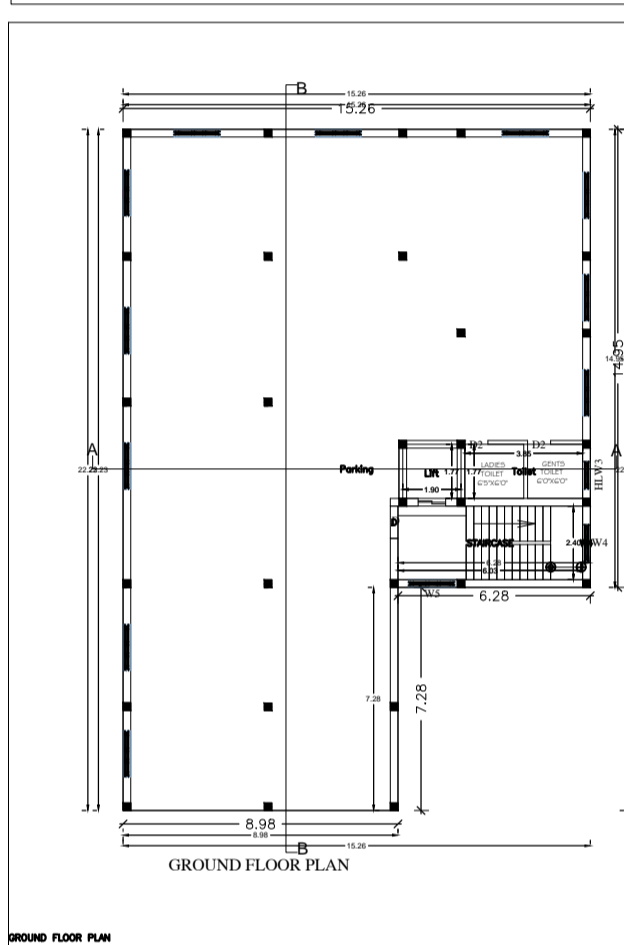
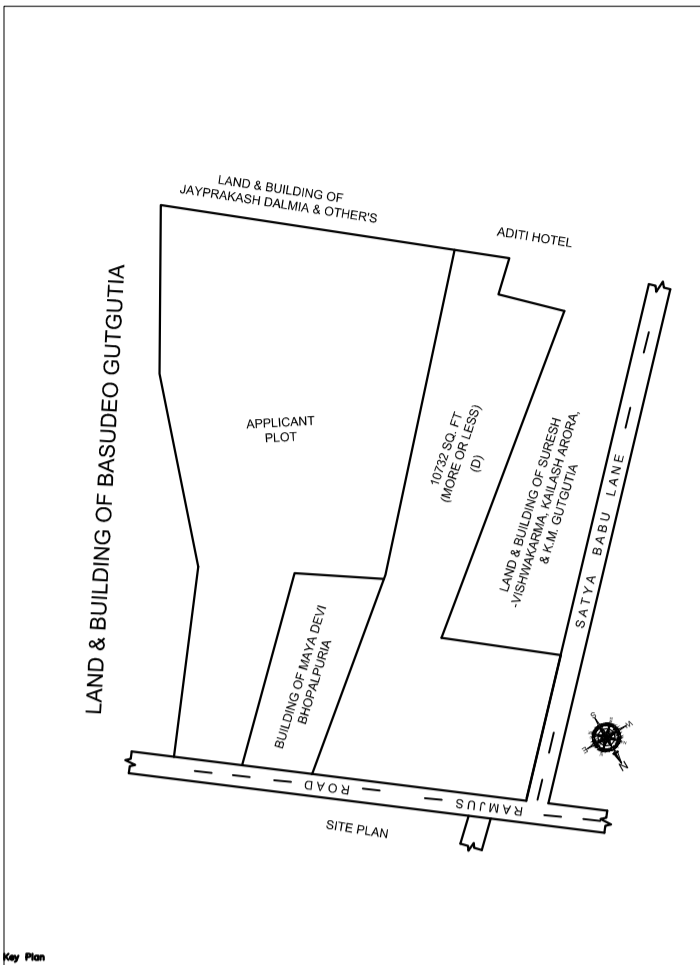
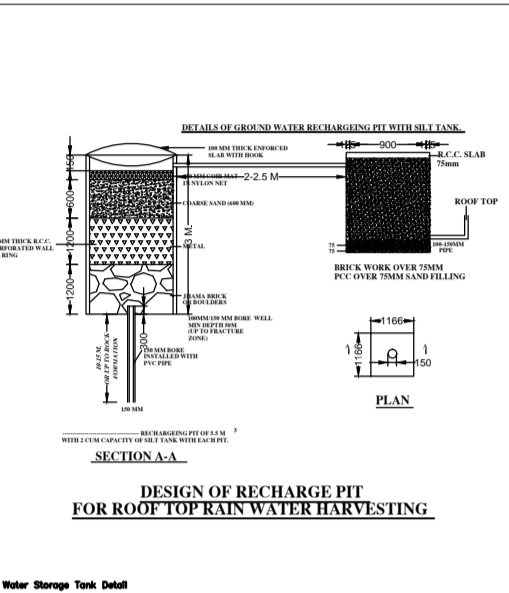
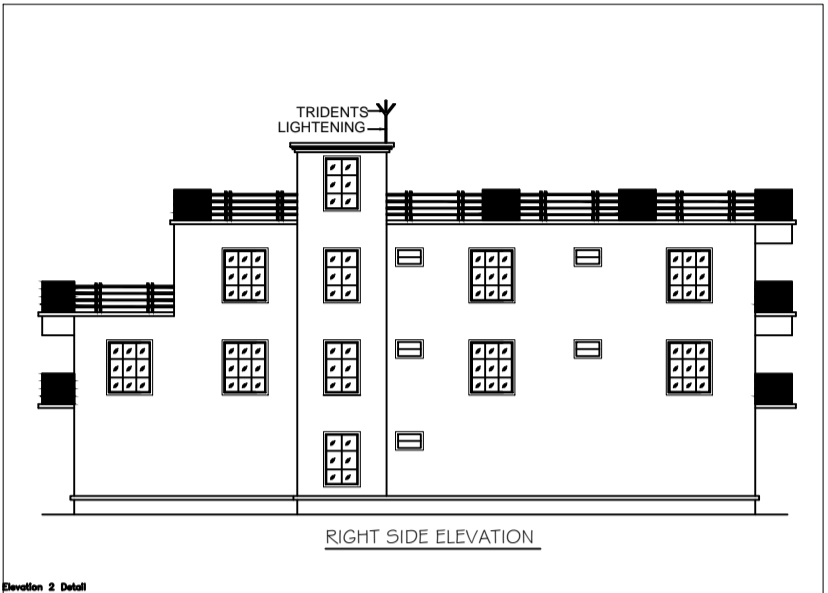
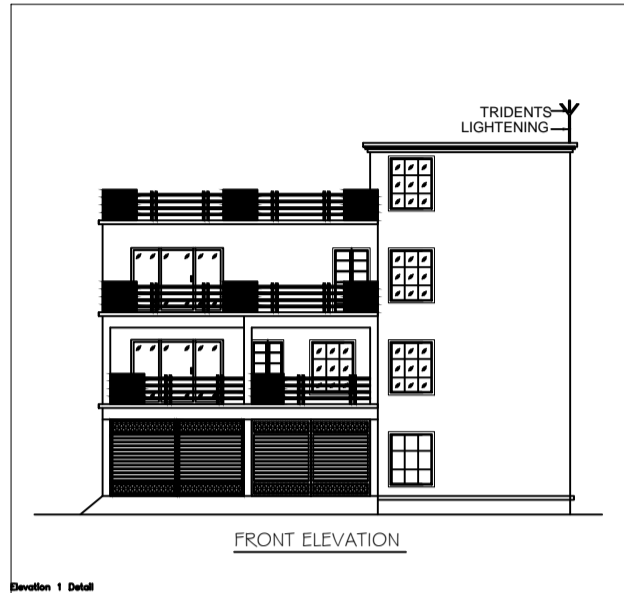
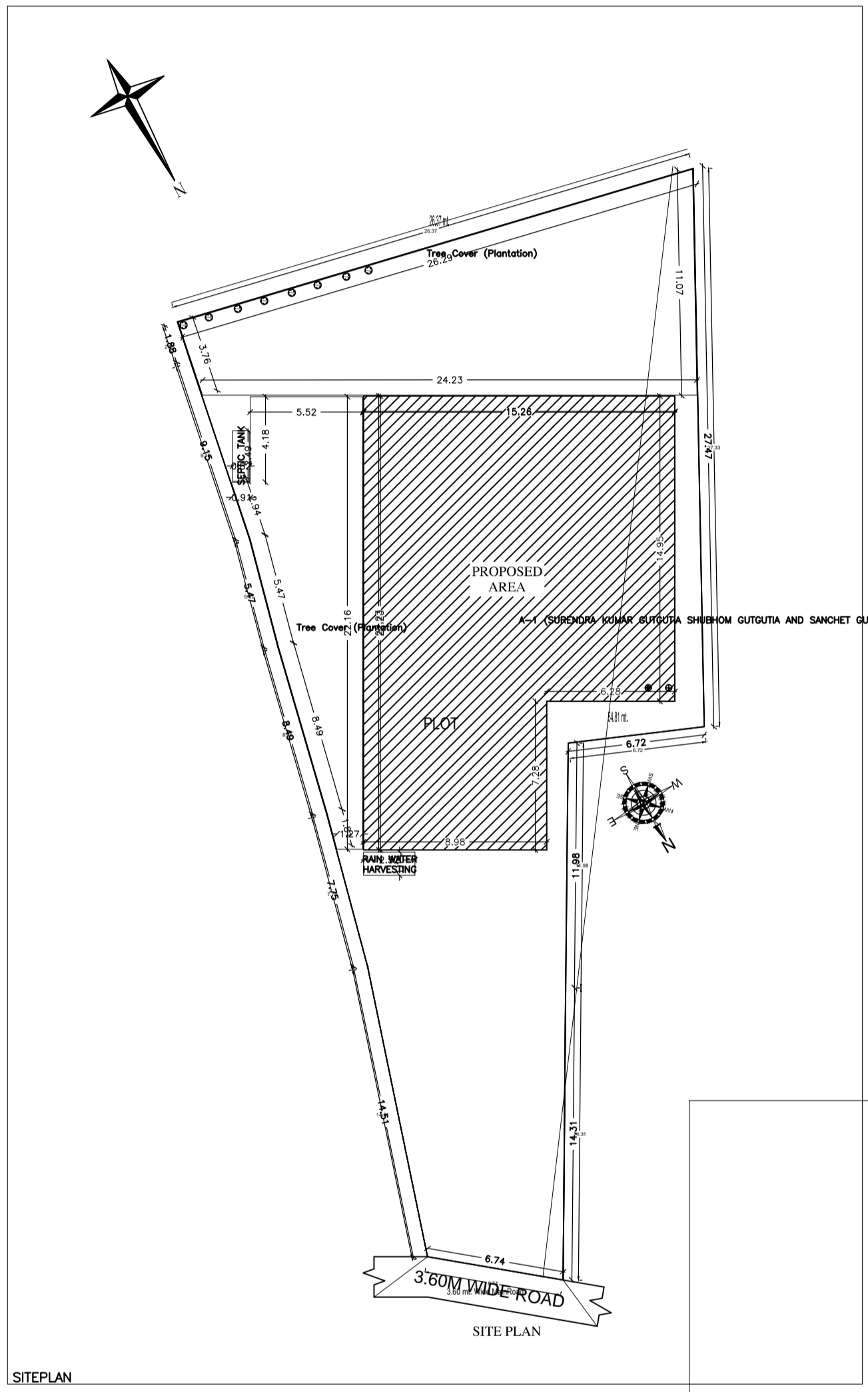

Table with columns for Material, Quantity, and Unit. Lists various construction materials like cement, sand, and bricks.

Table for Color Index, showing color codes for different parts of the building.

Table for Parking Calculation, detailing the number of parking spaces for different categories.

Table for PVI & Treatment Details, showing various parameters and their values.

Table with columns for Item, Quantity, and Unit. Lists items related to the project's schedule of work.

Table with columns for Item, Quantity, and Unit. Lists items related to the project's schedule of work.

Table with columns for Item, Quantity, and Unit. Lists items related to the project's schedule of work.

Table with columns for Item, Quantity, and Unit. Lists items related to the project's schedule of work.