

Proposal Basic Information	
Proposal File No.	MNP/IBP/0011/W08/2023
Owner Name	VISHNU RAJAK
Khata No	19K
Plot No	KA
Village Name	Madhupur Bazar
Use	Residential
SubUse	Bungalow/ Dwelling / Non Apartment

AREA STATEMENT MADHUPUR NAGAR PARISHAD	VERSION NO.: 1.0.66 VERSION DATE: 16/10/2020
PROJECT DETAIL:	
Region: JHARKHAND URBAN LOCAL BODIES	Plot Use: Residential
District: DEOGHAR	Plot SubUse: Bungalow/ Dwelling / Non Apartment
Authority: MADHUPUR NAGAR PARISHAD	Plot/Nearby/Religious/Structure: NA
Inward No: MNP/IBP/0011/W08/2023	Plot/SubPlot No: KA
Application Type: General Proposal	North: Plot No. - RAILWAY B CLASS LAND
Project Type: Building Permission	South: Road Width - 3.6
Nature of Development: New	East: Plot No. - VENDORS LAND
Location of Development Area: Old Area	West: Plot No. - LAND OF ASHOK RAJAK
AREA DETAILS:	
AREA OF PLOT (Minimum)	(A) 37.85 SQ.MT.
NET AREA OF PLOT (Gross Plot Area - Deduction from Gross Plot area)	(A-Deductions) 37.85
Deduction for Balance Plot Area (from Gross Plot Area)	
Common Plot	9.13
Total	9.13
BALANCE AREA OF PLOT (Net Plot Area - Recreational/Amenity space)	(A-Deductions) 28.72
PLOT AREA FOR COVERAGE (Net Plot Area)	(A-Deductions) 37.85
Plot Area for FAR (Net Plot Area + Road Widening Area)	(A-Deductions) 37.85
COVERAGE CHECK	
Permissible Coverage area (70.00 %)	26.49
Proposed Coverage Area (50.04 %)	18.94
Total Prop. Coverage Area (50.04 %)	18.94
Balance coverage area (19.95 %)	7.55
FAR CHECK	
Perm. FAR Area (1.500)	56.77
Total Perm. FAR area	56.77
Residential FAR	37.87
Proposed FAR Area	37.87
Total Proposed FAR Area	37.87
Consumed FAR (Factor)	1.00
Balance FAR Area	18.90
BUILT UP AREA CHECK	
Total Proposed BuiltUp Area	37.88
ARCHITECT (Regd)	PRAWEEEN KUMAR MAHTO
ENGINEER (Regd)	
SUPERVISOR (Regd)	
OWNER (Regd)	VISHNU RAJAK
DEVELOPMENT AUTHORITY	LOCAL BODY

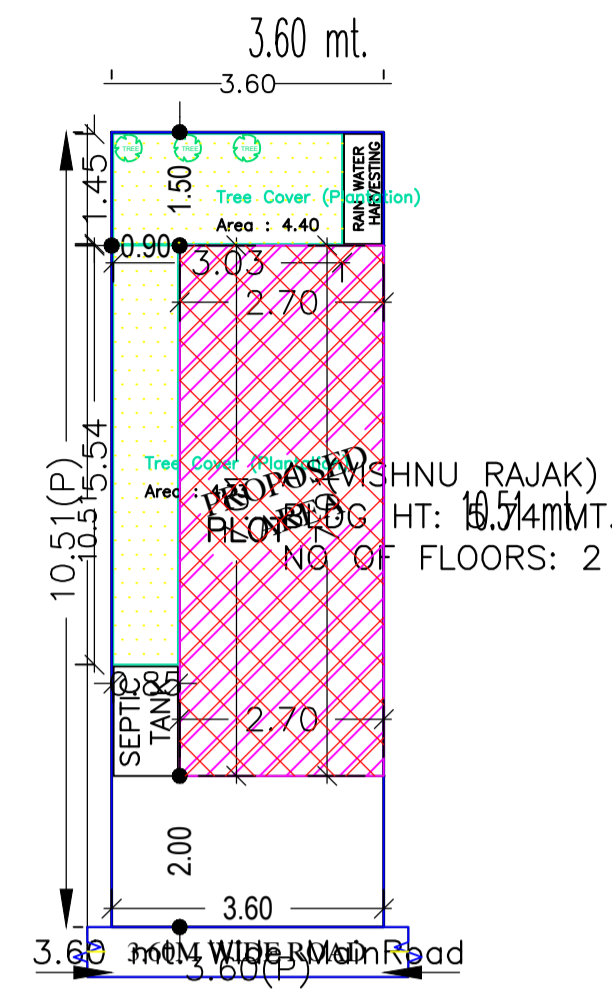

SITE PLAN

COLOR INDEX	
PLOT BOUNDARY	Black
ABUTTING ROAD	Green
PROPOSED CONSTRUCTION	Red
COMMON PLOT	Yellow
ROAD WIDENING AREA	Blue
EXISTING (To be retained)	Orange
EXISTING (To be demolished)	Light Blue

Building USE/SUBUSE Details

Building Name	Building Use	Building SubUse	Building Structure
A (VISHNU RAJAK)	Residential	Bungalow/ Dwelling / Non Apartment	Non-Highrise

Buildingwise Floor FAR Details

Floor Name	Building Name A (VISHNU RAJAK)		Total	
	Proposed Built Up Area (Sq.mt.)	Proposed FAR Area (Sq.mt.)	Total Proposed Built Up Area (Sq.mt.)	Total FAR Area (Sq.mt.)
Ground Floor	18.94	18.94	18.94	18.94
First Floor	18.94	18.94	18.94	18.94
Terrace Floor	0.00	0.00	0.00	0.00
Total :	37.88	37.88	37.88	37.88

FAR & Tenement Details (Table 4c-1)

Building	No. of Same Bldg	Total Built Up Area (Sq.mt.)	Proposed FAR Area (Sq.mt.) Resi.	Total FAR Area (Sq.mt.)	Total Consumed Additional FAR Area (Sq.mt.)	Tnmt (No.)
A (VISHNU RAJAK)	1	37.88	37.88	37.88	37.88	01
Grand Total :	1	37.88	37.88	37.88	37.88	01

LTP NAME AND SIGNATURE	STRUCTURAL ENG'S NAME AND SIGNATURE	BUILDER NAME AND SIGNATURE	DIGITAL SIGNATURE
PRAWEEEN KUMAR MAHTO MNP/ENG/0005/2020			

Proposal Basic Information	
Proposal File No.	MNP/BP/0011/W08/2023
Owner Name	VISHNU RAJAK
Khata No	19K
Plot No	KA
Village Name	Madhupur Bazar
Use	Residential
SubUse	Bungalow/ Dwelling / Non Apartment

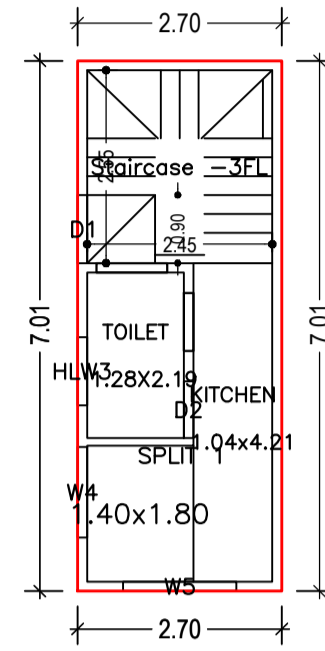

GROUND FLOOR PLAN
(Proposed)
(SCALE 1:100)

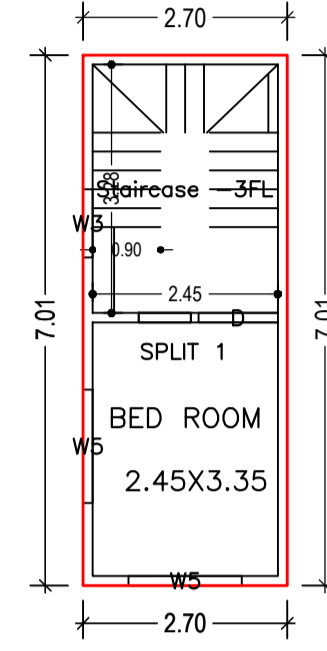

FIRST FLOOR PLAN
(Proposed)
(SCALE 1:100)

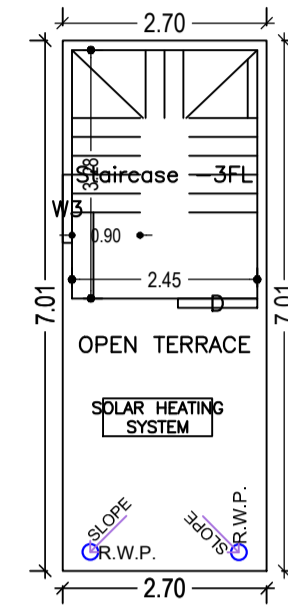

TERRACE FLOOR PLAN
(SCALE 1:100)

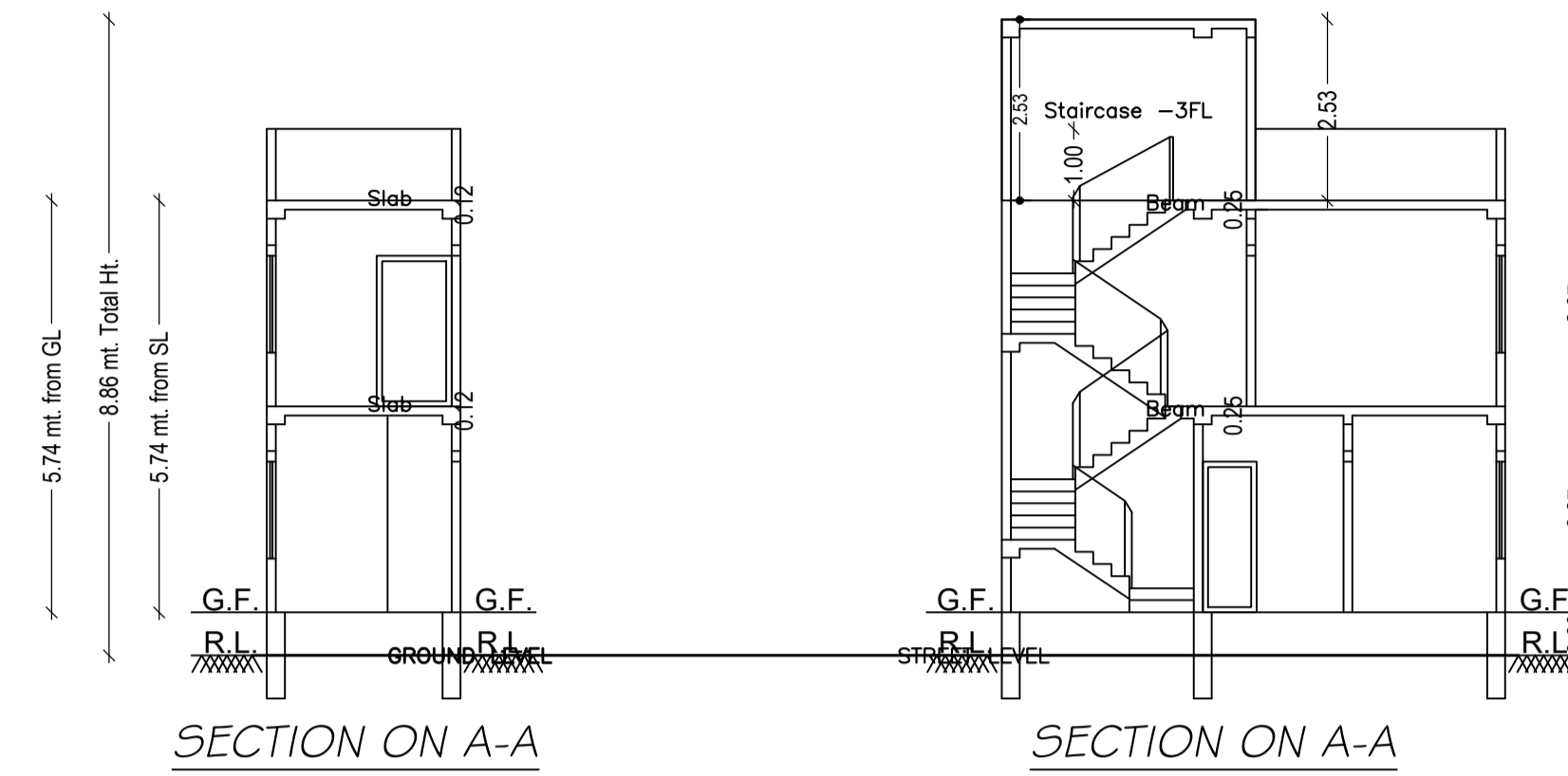

SCHEDULE OF DOOR:

BUILDING NAME	NAME	LENGTH	HEIGHT	NOS
A (VISHNU RAJAK)	D2	0.75	2.10	01
A (VISHNU RAJAK)	D	1.05	2.10	01

SCHEDULE OF WINDOW/VENTILATION:

BUILDING NAME	NAME	LENGTH	HEIGHT	NOS
A (VISHNU RAJAK)	HLW3	0.90	0.60	01
A (VISHNU RAJAK)	W3	0.90	1.35	02
A (VISHNU RAJAK)	W4	1.20	1.35	01
A (VISHNU RAJAK)	W5	1.50	1.35	03

UnitBUA Table for Building :A (VISHNU RAJAK)

FLOOR	Name	UnitBUA Type	UnitBUA Area	Carpet Area	No. of Rooms	No. of Tenement
GROUND FLOOR PLAN	SPLIT 1	FLAT	21.45	21.15	2	1
FIRST FLOOR PLAN	SPLIT 1	FLAT	0.00	0.00	1	0
Total:	-	-	21.45	21.15	3	1

Building :A (VISHNU RAJAK)

Floor Name	Total Built Up Area (Sq.mt.)	Proposed FAR Area (Sq.mt.) Resi.	Total FAR Area (Sq.mt.)	Total Consumed Additional FAR Area (Sq.mt.)	Tnmt (No.)
Ground Floor	18.94	18.94	18.94	18.94	01
First Floor	18.94	18.94	18.94	18.94	00
Terrace Floor	0.00	0.00	0.00	0.00	00
Total :	37.88	37.88	37.88	37.88	01
Total Number of Same Buildings :	1				
Total :	37.88	37.88	37.88	37.88	01

LTP NAME AND SIGNATURE	STRUCTURAL ENG'S NAME AND SIGNATURE	BUILDER NAME AND SIGNATURE	DIGITAL SIGNATURE
PRAWEEEN KUMAR MAHTO MNP/ENG/0005/2020			

Proposal Basic Information	
Proposal File No.	MNP/BP/0011/W08/2023
Owner Name	VISHNU RAJAK
Khata No	19K
Plot No	KA
Village Name	Madhupur Bazar
Use	Residential
SubUse	Bungalow/ Dwelling / Non Apartment



3.60M WIDE ROAD

KEY PLAN

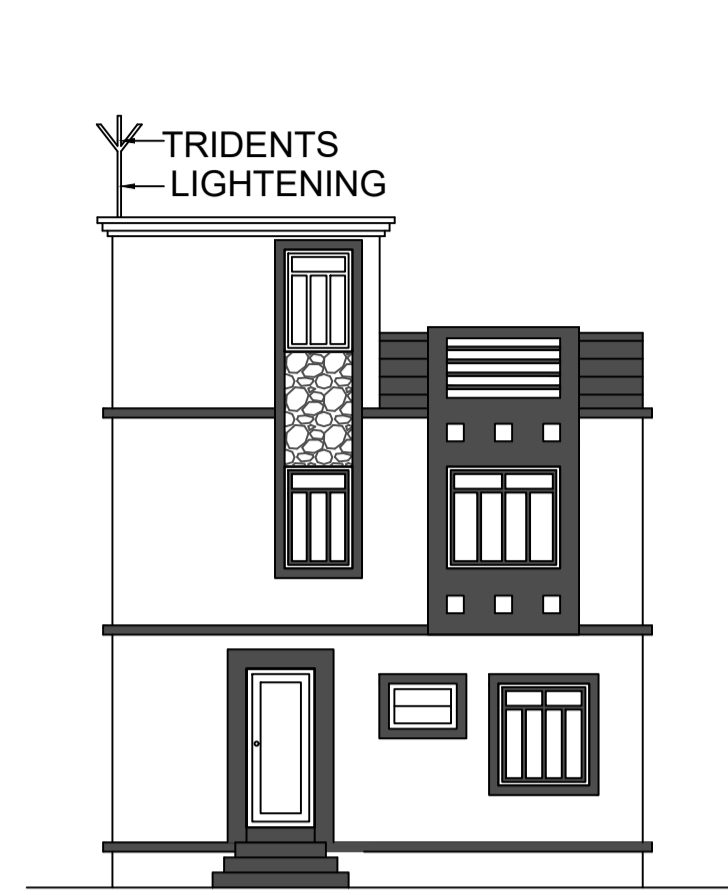

L.H.S. ELEVATION

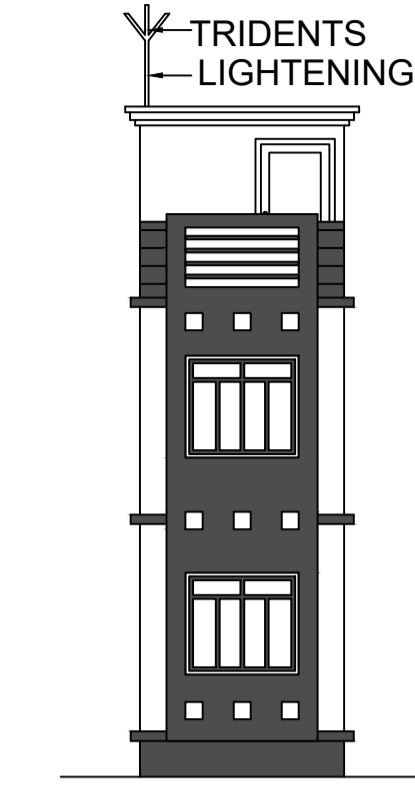

FRONT ELEVATION

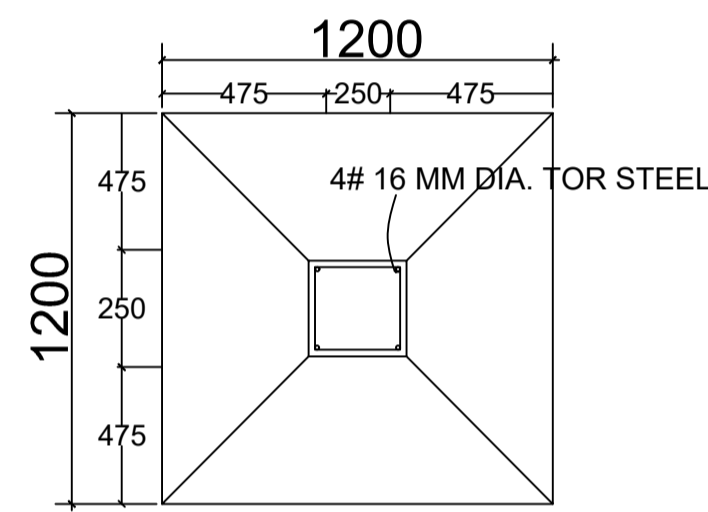

PLAN

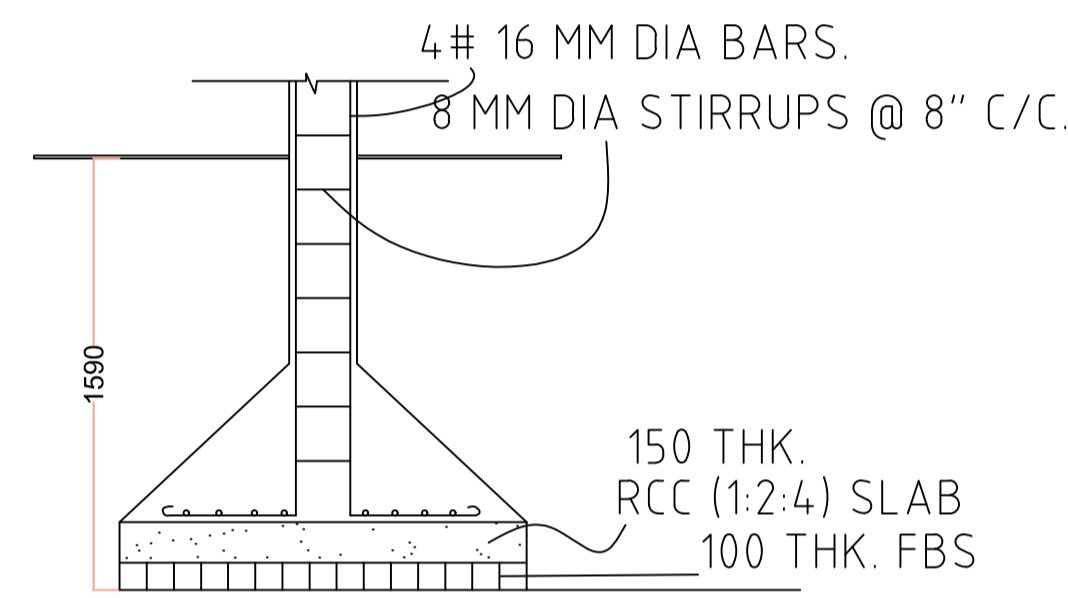

SECTION

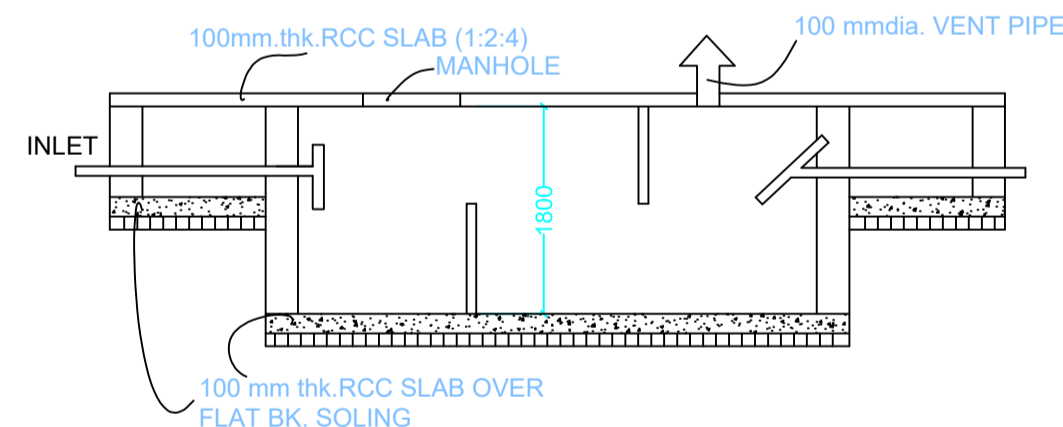

SECTION
SCALE 1:50
SEPTIC TANK DETAILS

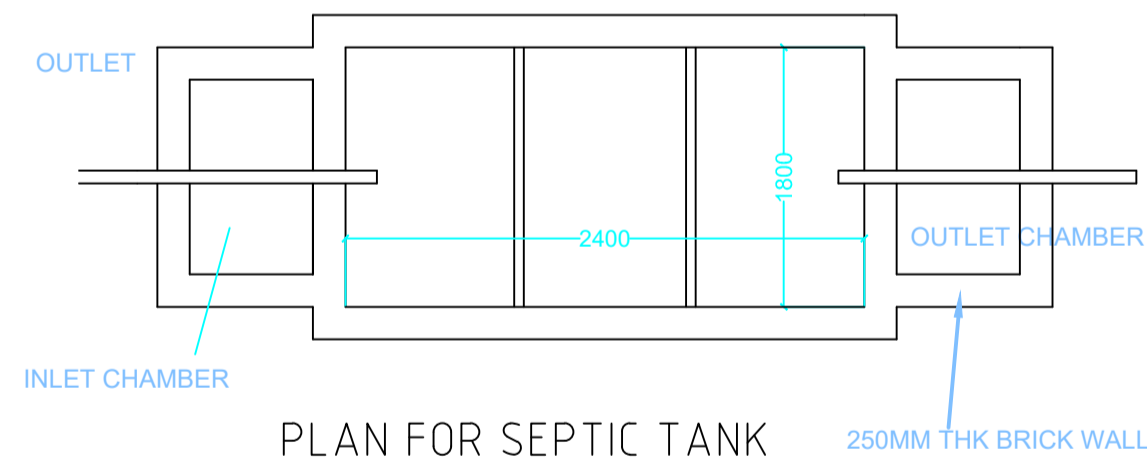

PLAN FOR SEPTIC TANK

SALIM BROTHER SHOP

LOCATION MAP

HAZI GALI ROAD

APPLICANT PLOT

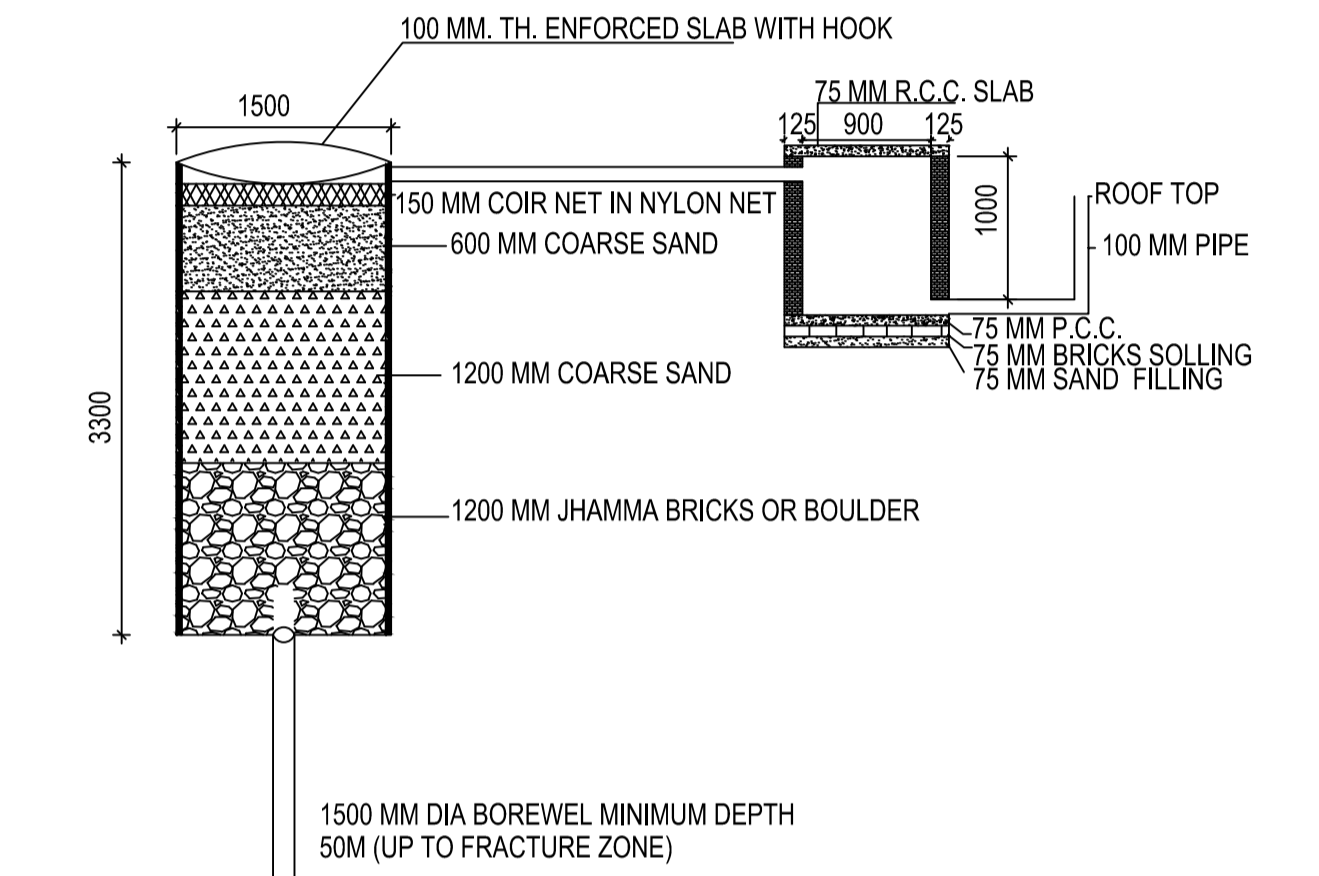

DETAIL OF GROUND WATER
RECHARGING PIT WITH SILT TANK
SCALE - N.T.S.

This is certify that the structure design is in accordance with the latest I-S code(I-S 875, I-S456-2002, I-S 1893-2000) for design & loading conditions (Sessmic/wind/dead/live) and other all parameters are taken in account for safetyof the structure.

LTP NAME AND SIGNATURE	STRUCTURAL ENG'S NAME AND SIGNATURE	BUILDER NAME AND SIGNATURE	DIGITAL SIGNATURE
PRAWEEEN KUMAR MAHTO MNP/ENG/0005/2020			