

AREA STATEMENT MADHUPUR NAGAR PARISHAD	VERSION NO.- 1.0.66 VERSION DATE: 16/10/2020		
PROJECT DETAIL:			
Region: JHARKHAND URBAN LOCAL BODIES	Plot Use: Residential		
District: DEOGHAR	Plot SubUse: Bungalow/ Dwelling / Non Apartment		
Authority: MADHUPUR NAGAR PARISHAD	PlotNearby/ReligiousStructure: NA		
Inward No: MNP/BP/0010/W21/2023	Plot/SubPlot No: 407		
Application Type: General Proposal	North: Plot No. - SUB PLOT NO- 36		
Project Type: Building Permission	South: Plot No. - SUB PLOT NO- 37		
Nature of Development: New	East: Road Width - 3.6		
Location of Development Area: Old Area	West: Plot No. - SUB PLOT NO- 35		
AREA DETAILS:			
AREA OF PLOT (Minimum)	(A)	SQ. MT.	157.84
NET AREA OF PLOT(Gross Plot Area - Deduction from Gross Plot area)	(A-Deductions)		157.84
Deduction for Balance Plot Area(from Gross Plot Area)			
Common Plot			23.45
Total			23.45
BALANCE AREA OF PLOT(Net Plot Area - Recreational/Amenity space)	(A-Deductions)		134.39
PLOT AREA FOR COVERAGE(Net Plot Area)	(A-Deductions)		157.84
Plot Area for FAR (Net Plot Area + RoadWidening Area)	(A-Deductions)		157.84
COVERAGE CHECK			
Permissible Coverage area (70.00 %)			110.49
Proposed Coverage Area (59.60 %)			94.08
Total Prop. Coverage Area (59.6 %)			94.08
Balance coverage area (10.40 %)			16.41
FAR CHECK			
Perm. FAR Area (1.500)			236.76
Total Perm. FAR area			236.76
Residential FAR			151.96
Proposed FAR Area			151.96
Total Proposed FAR Area			151.96
Consumed FAR (Factor)			0.96
Balance FAR Area			84.80
BUILT UP AREA CHECK			
Total Proposed BuiltUp Area			188.16
ARCHITECT (Regd)		PRAWEEEN KUMAR MAHTO	
ENGINEER (Regd)			
SUPERVISOR (Regd)			
OWNER (Regd)		SARITA DEVI	
DEVELOPMENT AUTHORITY		LOCAL BODY	

COLOR INDEX	
PLOT BOUNDARY	Black
ABUTTING ROAD	Green
PROPOSED CONSTRUCTION	Red
COMMON PLOT	Yellow
ROAD WIDENING AREA	Blue
EXISTING (To be retained)	Orange
EXISTING (To be demolished)	Light Blue

Buildingwise Floor FAR Details

Floor Name	Building Name A (SARITA DEVI)		Total	
	Proposed Built Up Area (Sq.mt.)	Proposed FAR Area (Sq.mt.)	Total Proposed Built Up Area (Sq.mt.)	Total FAR Area (Sq.mt.)
Ground Floor	94.08	57.88	94.08	57.88
First Floor	94.08	94.08	94.08	94.08
Terrace Floor	0.00	0.00	0.00	0.00
Total :	188.16	151.96	188.16	151.96

Building USE/SUBUSE Details

Building Name	Building Use	Building SubUse	Building Structure
A (SARITA DEVI)	Residential	Bungalow/ Dwelling / Non Apartment	Non-Highrise

FAR & Tenement Details (Table 4c-1)

Building	No. of Same Bldg	Total Built Up Area (Sq.mt.)	Deductions (Area in Sq.mt.)		Proposed FAR Area (Sq.mt.)	Total FAR Area (Sq.mt.)	Total Consumed Additional FAR Area (Sq.mt.)	Tnmt (No.)
			Parking	Resl.				
A (SARITA DEVI)	1	188.16	36.20	151.96	151.96	151.96	151.96	01
Grand Total :	1	188.16	36.20	151.96	151.96	151.96	151.96	01

SITE PLAN

Proposal Basic Information	
Proposal File No.	MNP/BP/0010/W21/2023
Owner Name	SARITA DEVI
Khata No	59/30
Plot No	407
Village Name	Patharchptti
Use	Residential
SubUse	Bungalow/ Dwelling / Non Apartment

LTP NAME AND SIGNATURE	STRUCTURAL ENG'S NAME AND SIGNATURE	BUILDER NAME AND SIGNATURE	DIGITAL SIGNATURE
PRAWEEEN KUMAR MAHTO MNP/ENG/0005/2020			

Proposal Basic Information

Proposal File No.	MNP/BP/0010/W21/2023
Owner Name	SARITA DEVI
Khata No	59/30
Plot No	407
Village Name	Patharchptti
Use	Residential
SubUse	Bungalow/ Dwelling / Non Apartment

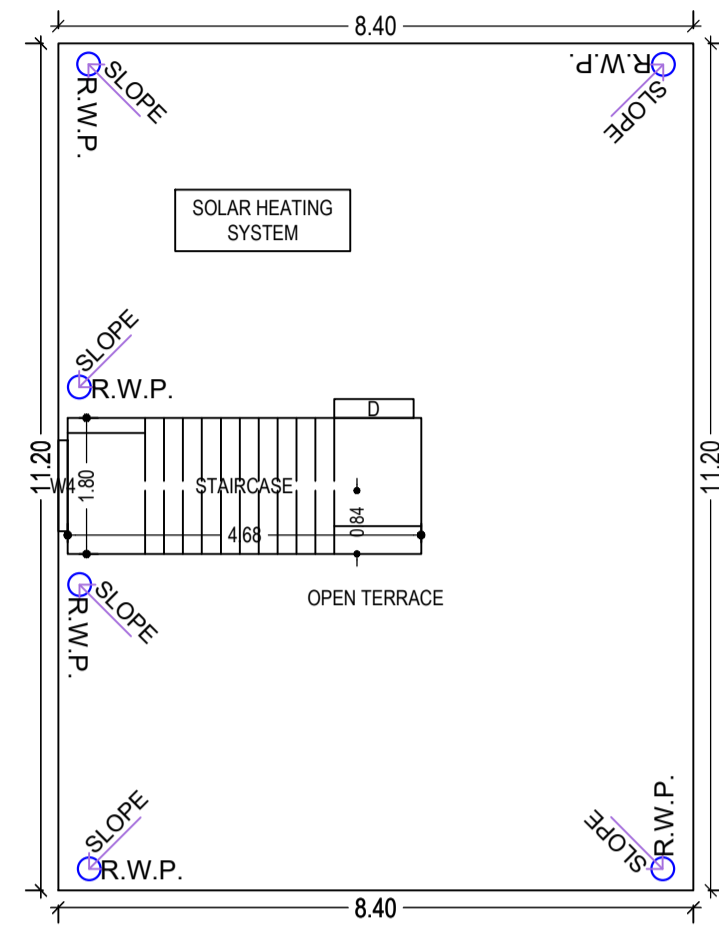

TERRACE FLOOR PLAN
(SCALE 1:100)

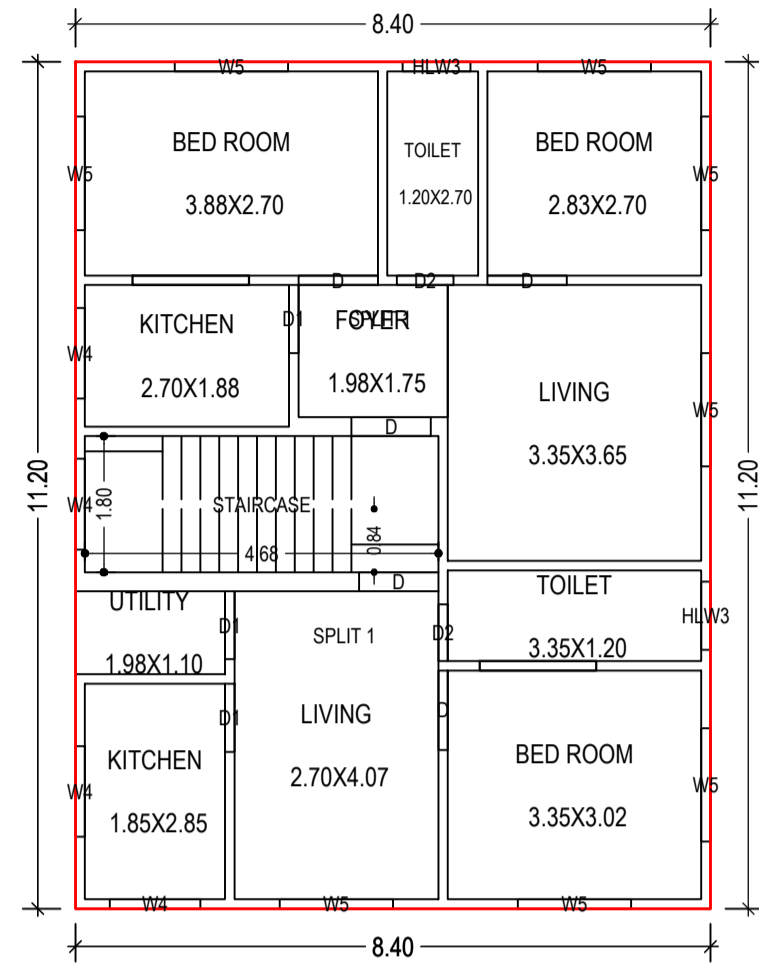

FIRST FLOOR PLAN
(Proposed)
(SCALE 1:100)

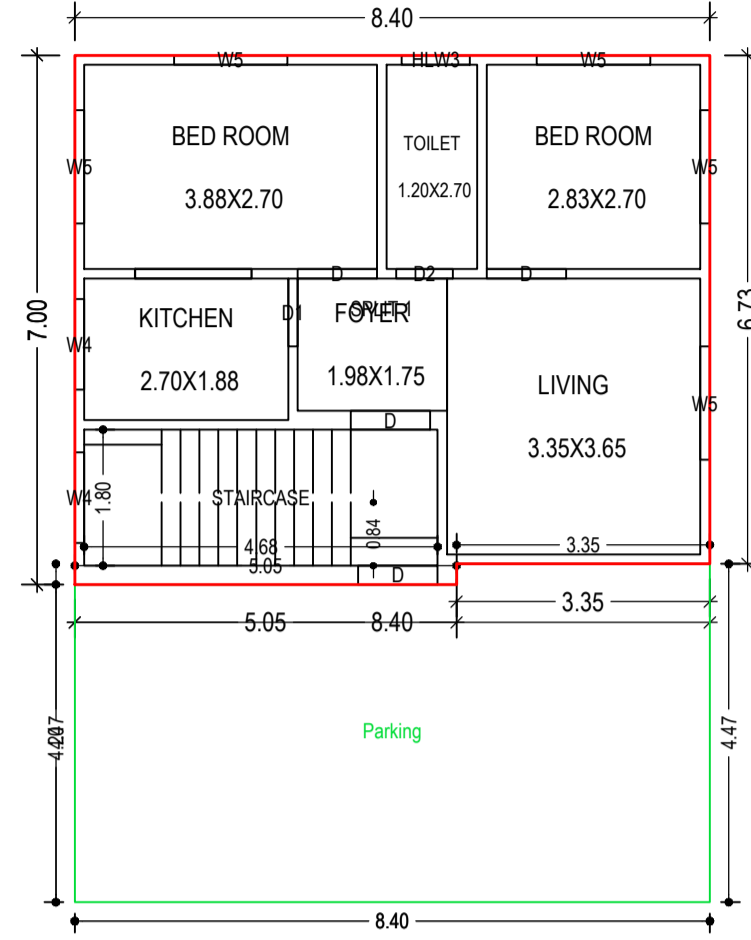

GROUND FLOOR PLAN
(Proposed)
(SCALE 1:100)

Building :A (SARITA DEVI)

Floor Name	Total Built Up Area (Sq.mt.)	Deductions (Area in Sq.mt.)		Proposed FAR Area (Sq.mt.)	Total FAR Area (Sq.mt.)	Total Consumed Additional FAR Area (Sq.mt.)	Tnmt (No.)
		Parking	Resi.				
Ground Floor	94.08	36.20	57.88	57.88	57.88	57.88	01
First Floor	94.08	0.00	94.08	94.08	94.08	94.08	00
Terrace Floor	0.00	0.00	0.00	0.00	0.00	0.00	00
Total :	188.16	36.20	151.96	151.96	151.96	151.96	01
Total Number of Same Buildings :	1						
Total :	188.16	36.20	151.96	151.96	151.96	151.96	01

SCHEDULE OF DOOR:

BUILDING NAME	NAME	LENGTH	HEIGHT	NOS
A (SARITA DEVI)	D2	0.75	2.10	03
A (SARITA DEVI)	D1	0.90	2.10	04
A (SARITA DEVI)	D	1.05	2.10	08

SCHEDULE OF WINDOW/VENTILATION:

BUILDING NAME	NAME	LENGTH	HEIGHT	NOS
A (SARITA DEVI)	HLW3	0.90	0.60	03
A (SARITA DEVI)	W4	1.20	1.35	07
A (SARITA DEVI)	W5	1.50	1.35	13

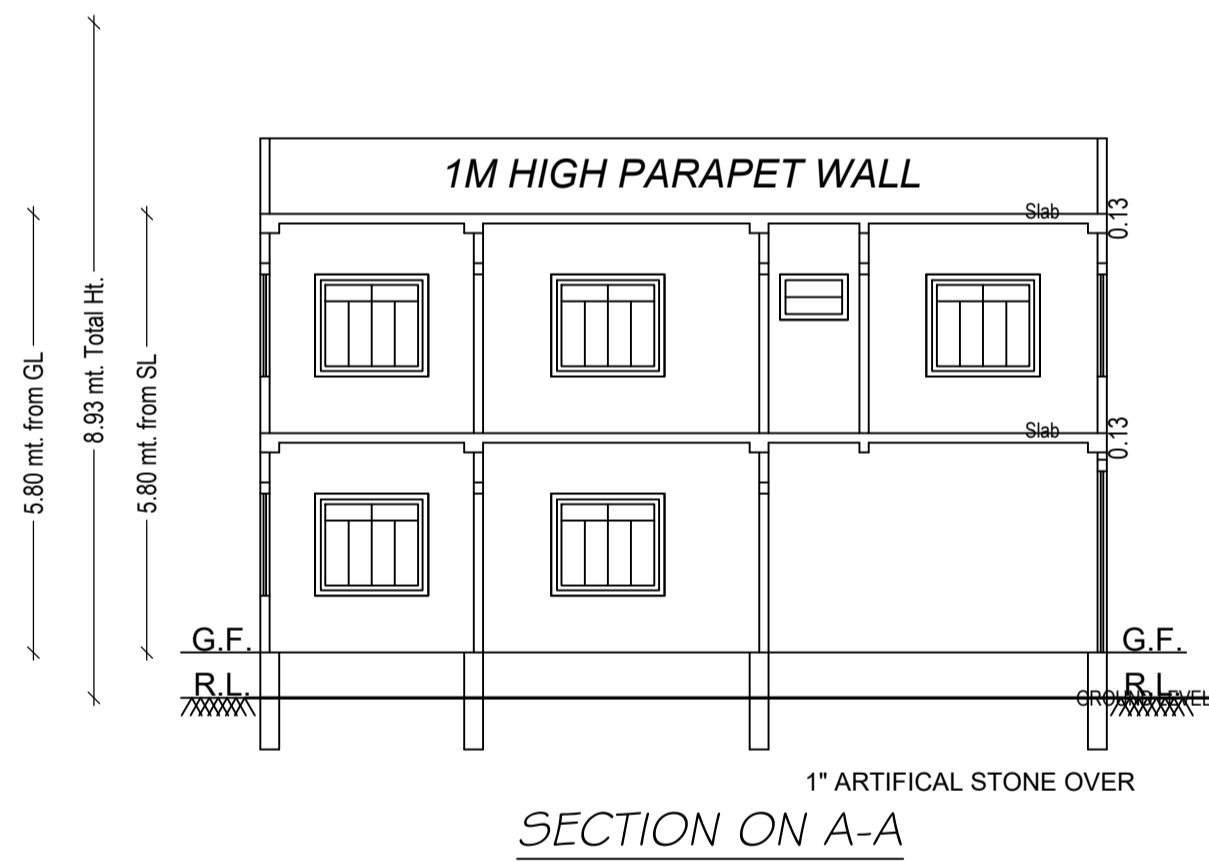

SECTION ON A-A

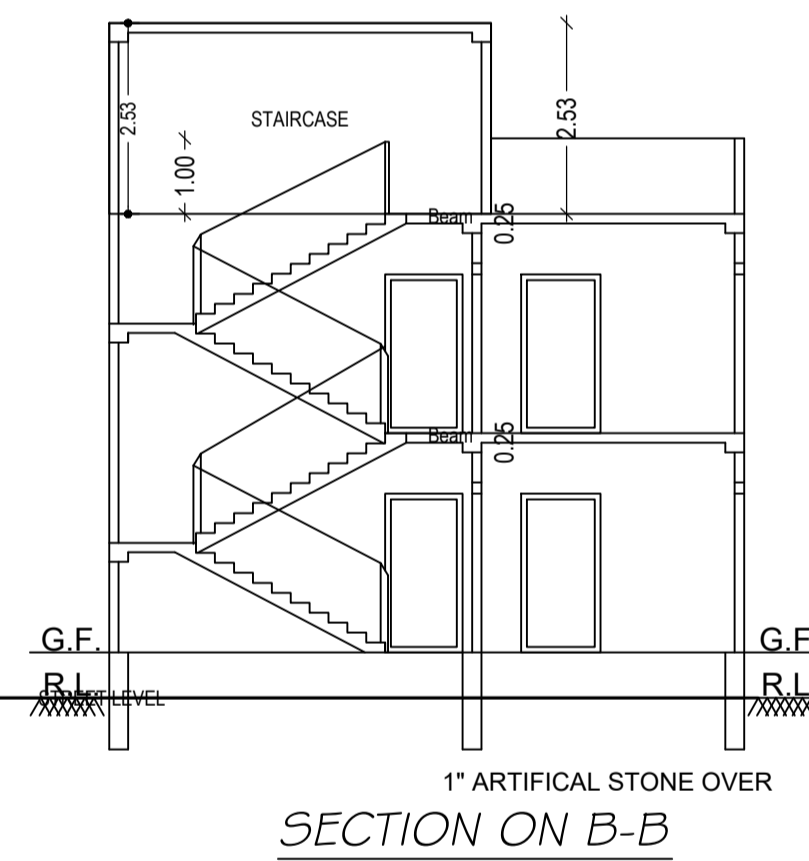

SECTION ON B-B

UnitBUA Table for Building :A (SARITA DEVI)

FLOOR	Name	UnitBUA Type	UnitBUA Area	Carpet Area	No. of Rooms	No. of Tenement
FIRST FLOOR PLAN	SPLIT 1	FLAT	0.00	0.00	6	0
GROUND FLOOR PLAN	SPLIT 1	FLAT	133.41	132.83	6	1
Total	-	-	133.41	132.83	17	1

LTP NAME AND SIGNATURE	STRUCTURAL ENG'S NAME AND SIGNATURE	BUILDER NAME AND SIGNATURE	DIGITAL SIGNATURE
PRAWEEEN KUMAR MAHTO MNP/ENG/0005/2020			

Proposal Basic Information

Proposal File No.	MNP/BP/0010/W21/2023
Owner Name	SARITA DEVI
Khata No	59/30
Plot No	407
Village Name	Patharchptti
Use	Residential
SubUse	Bungalow/ Dwelling / Non Apartment

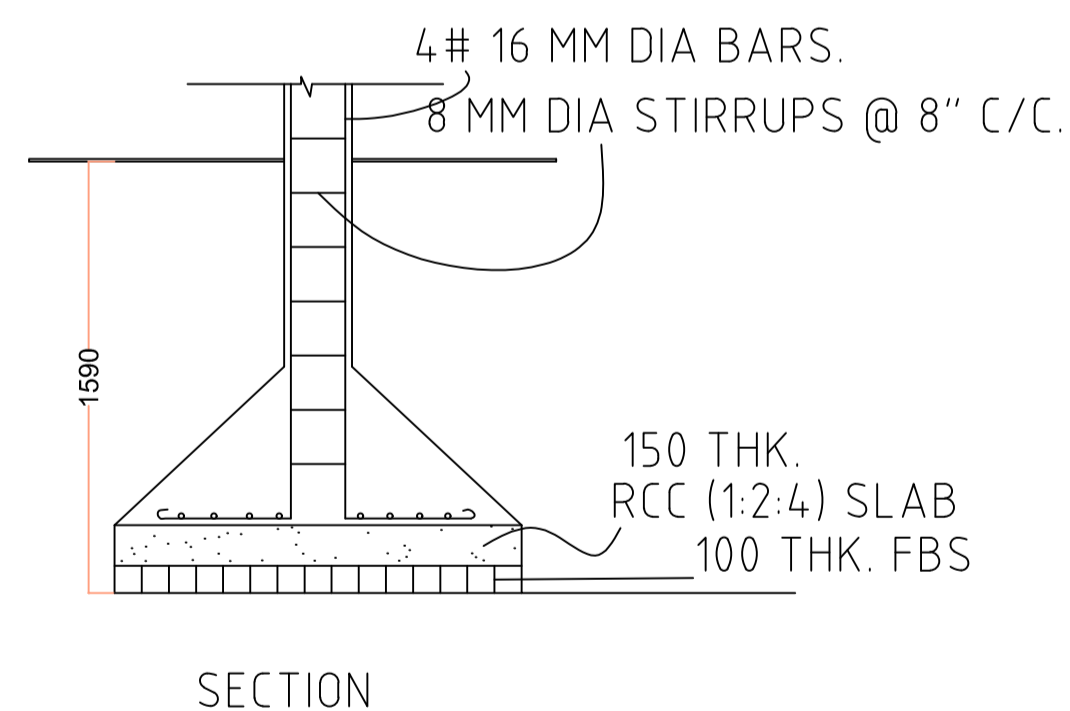
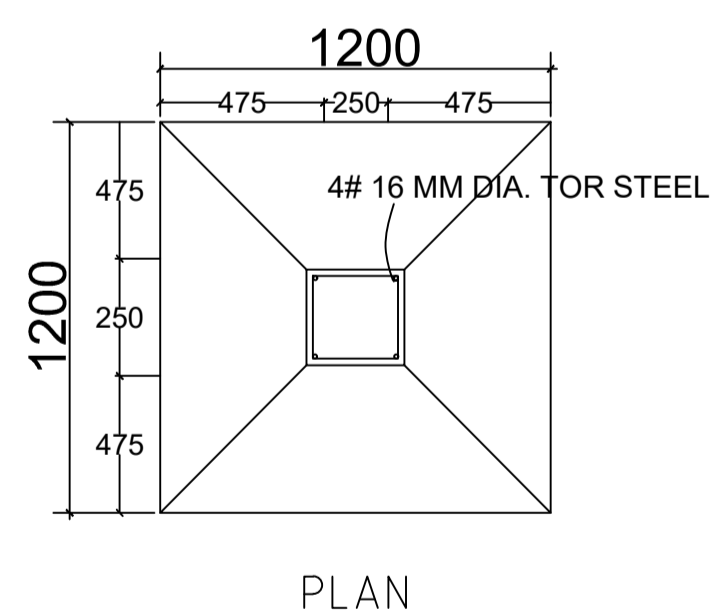
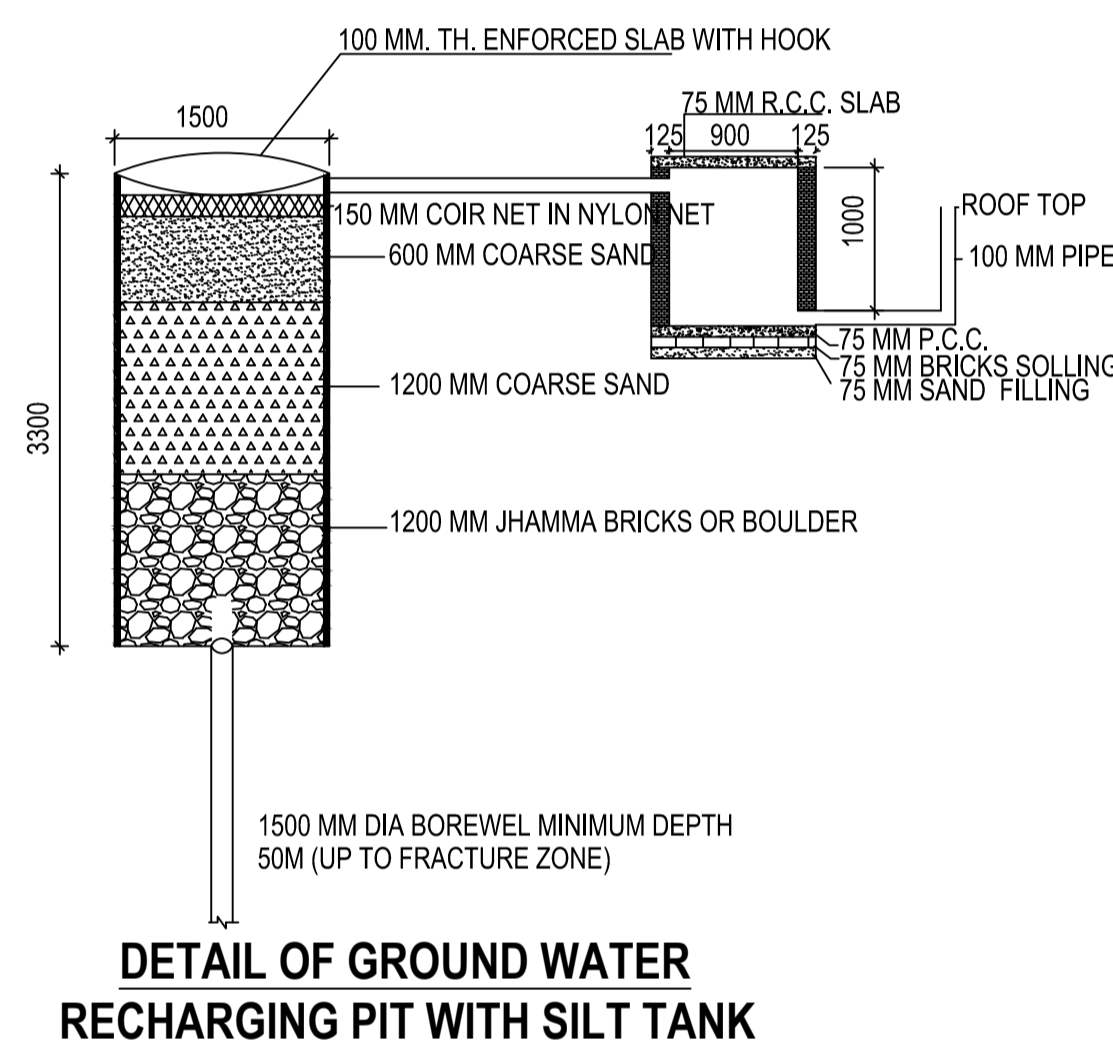
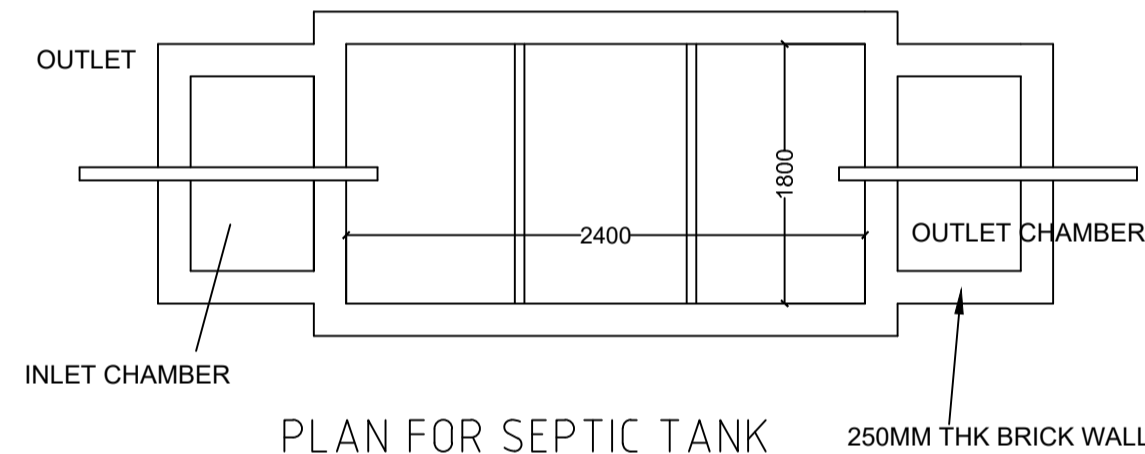
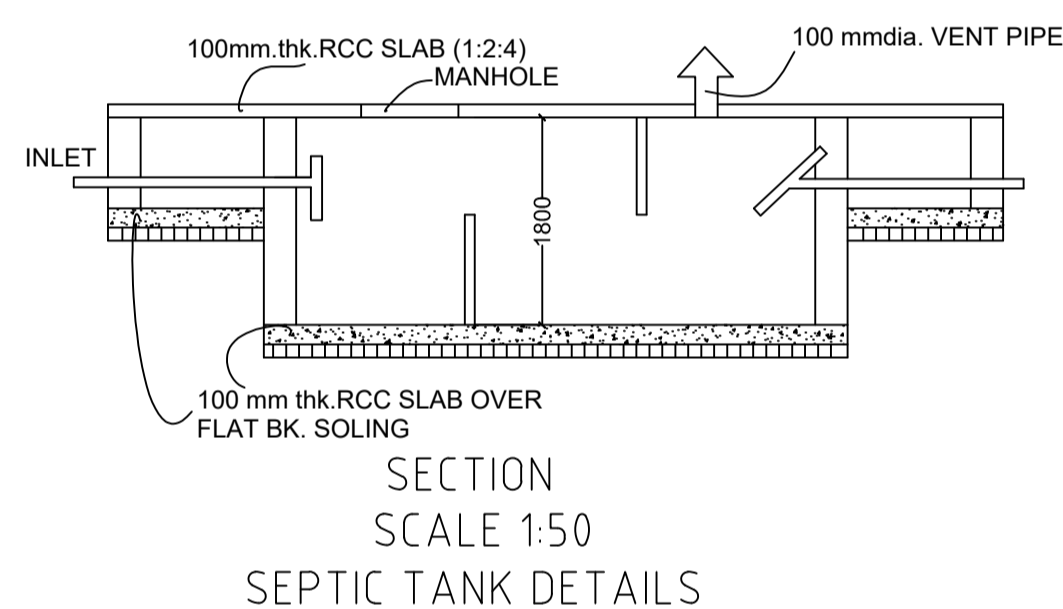
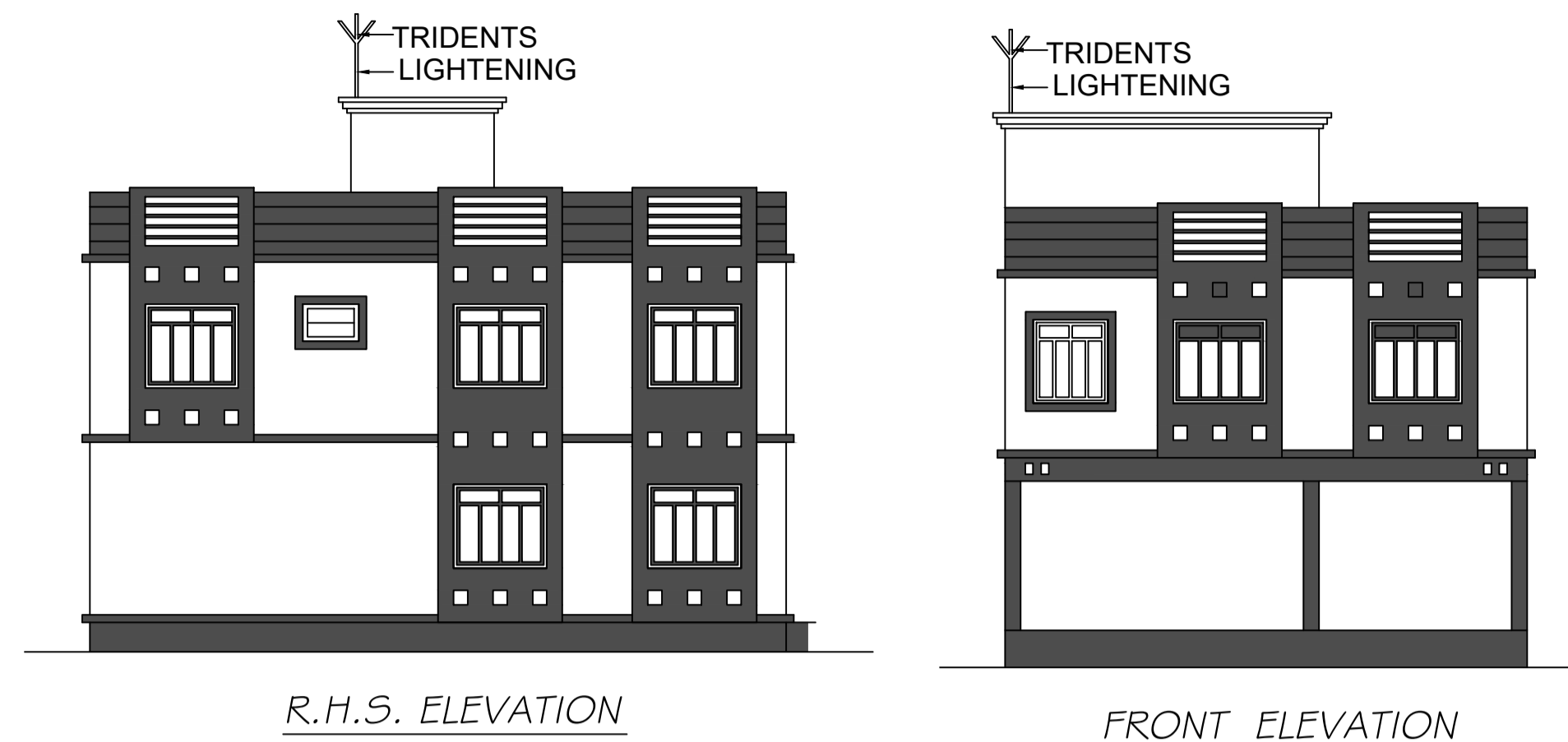
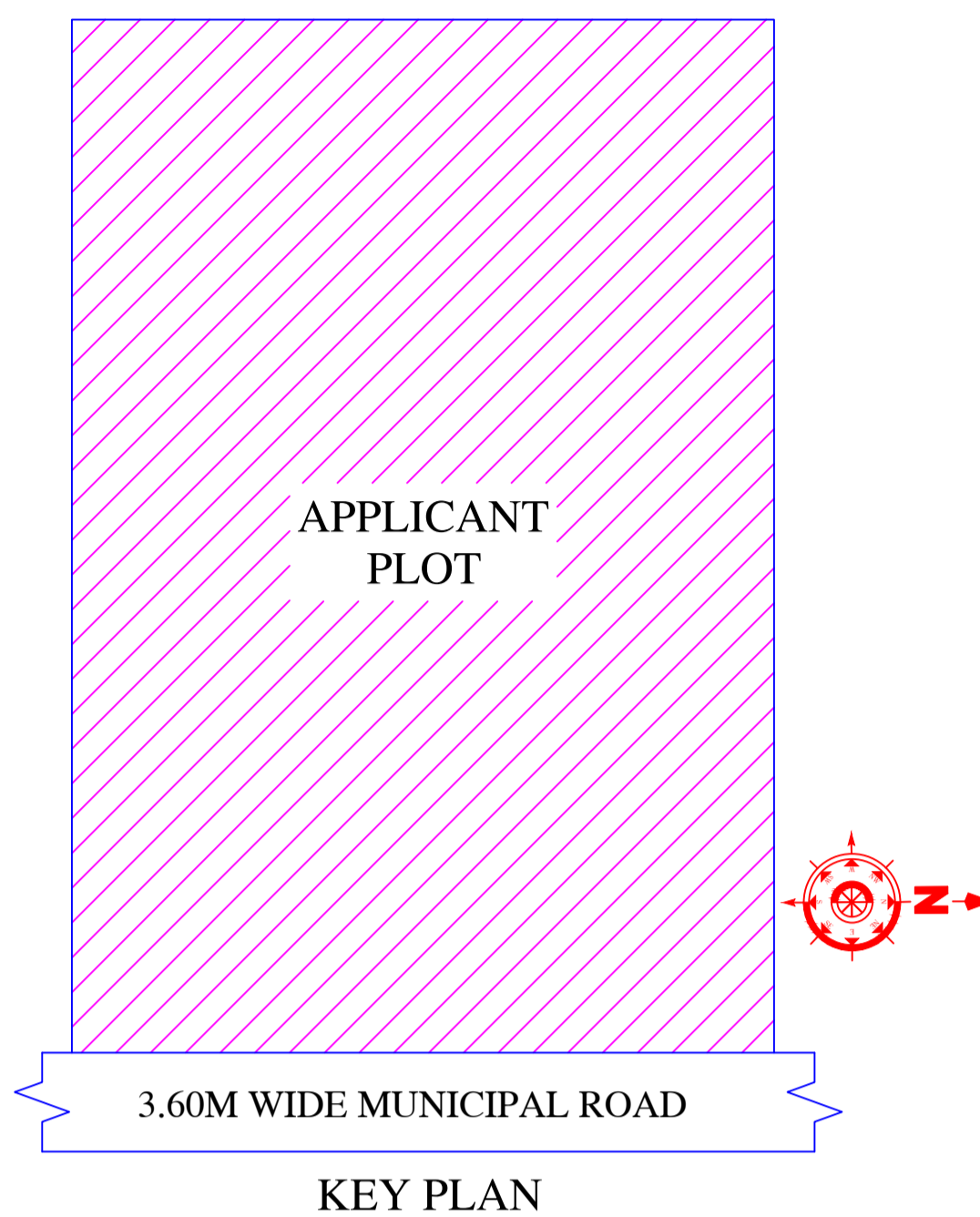
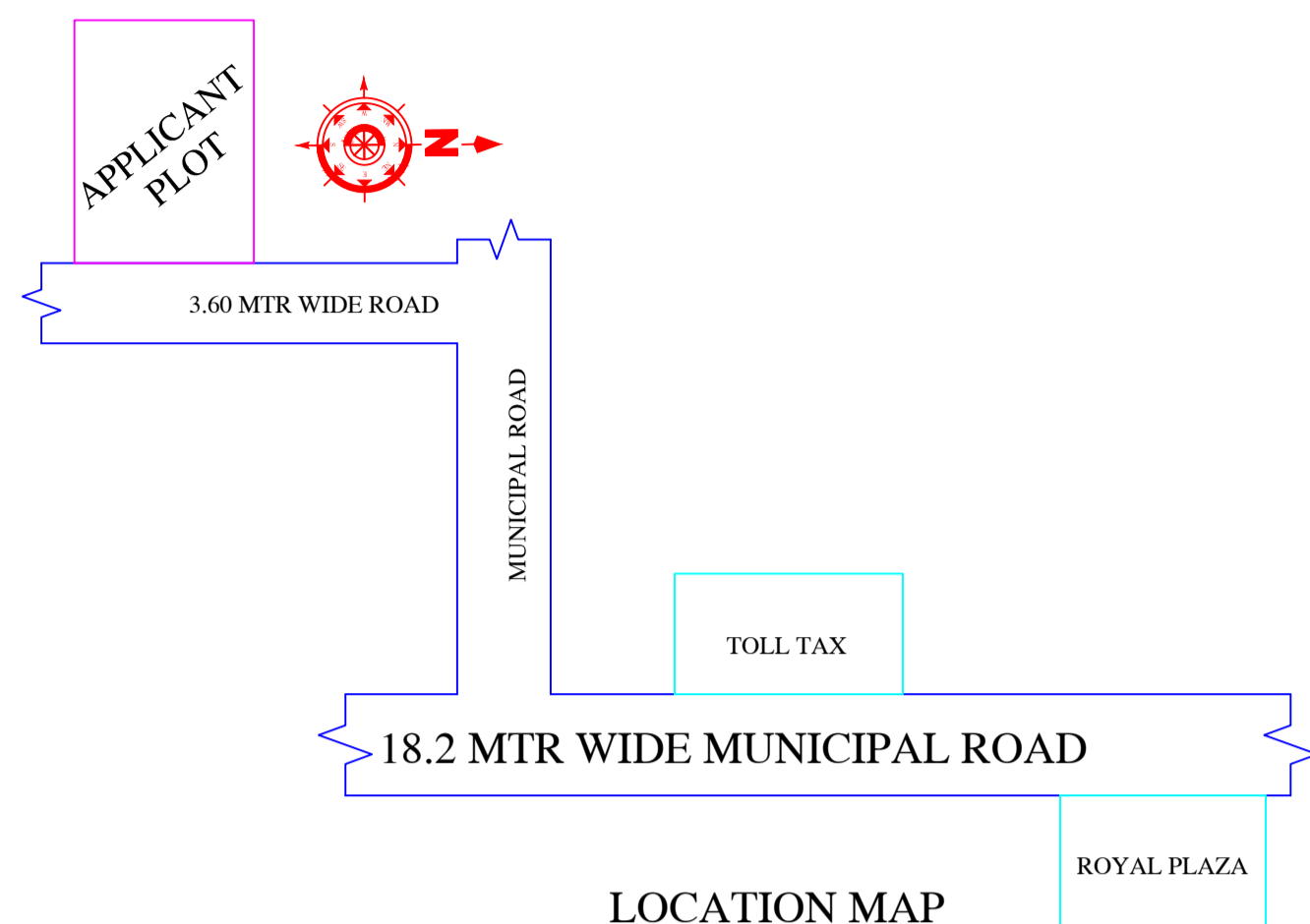

This is certify that the structure design is in accordance with the latest I-S code(I-S 875,I-S456-2002, I-S 1893-2000) for design & loading conditions (Sessmic/wind/dead/live) and other all parameters are taken in account for safetyof the structure.

LTP NAME AND SIGNATURE	STRUCTURAL ENG'S NAME AND SIGNATURE	BUILDER NAME AND SIGNATURE	DIGITAL SIGNATURE
PRAWEEEN KUMAR MAHTO MNP/ENG/0005/2020			