

Proposal Basic Information	
Proposal File No.	MNP/BP/0003/W09/2023
Owner Name	BABITA KUMARI
Khata No	67
Plot No	0/1
Village Name	Madhupur Khas
Use	Residential
SubUse	Bungalow/ Dwelling / Non Apartment

AREA STATEMENT		VERSION NO. : 1.0.65
MADHUPUR NAGAR PARISHAD		VERSION DATE: 16/10/2020
PROJECT DETAIL:		
Region: JHARKHAND URBAN LOCAL BODIES	Plot Use: Residential	
District: DEOGHAR	Plot SubUse: Bungalow/ Dwelling / Non Apartment	
Authority: MADHUPUR NAGAR PARISHAD	PlotNearby/ReligiousStructure: NA	
Inward No: MNP/BP/0003/W09/2023	Plot/SubPlot No: 0/1	
Application Type: General Proposal	North: Plot No. - LAND OF PRADEEP PRASAD	
Project Type: Building Permission	South: Plot No. - LAND OF JITENDRA PRASAD	
Nature of Development: New	East: Plot No. - LAND OF KISHOR TANTI	
Location of Development Area: Old Area	West: Road Width - 3.6	
AREA DETAILS:		
AREA OF PLOT (Minimum)	(A)	73.32
NET AREA OF PLOT(Gross Plot Area - Deduction from Gross Plot area)	(A-Deductions)	73.32
Deduction for Balance Plot Area(from Gross Plot Area)		
Common Plot		16.50
Total		16.50
BALANCE AREA OF PLOT(Net Plot Area - Recreational/Amenity space)	(A-Deductions)	56.82
PLOT AREA FOR COVERAGE(Net Plot Area)	(A-Deductions)	73.32
Plot Area for FAR (Net Plot Area + RoadWidening Area)	(A-Deductions)	73.32
COVERAGE CHECK		
Permissible Coverage area (70.00 %)		51.32
Proposed Coverage Area (59.92 %)		43.93
Total Prop. Coverage Area (59.92 %)		43.93
Balance coverage area (10.08 %)		7.39
FAR CHECK		
Perm. FAR Area (1.500)		109.98
Total Perm. FAR area		109.98
Residential FAR		43.93
Proposed FAR Area		43.93
Total Proposed FAR Area		43.93
Consumed FAR (Factor)		0.60
Balance FAR Area		66.05
BUILT UP AREA CHECK		
Total Proposed BuiltUp Area		43.93
ARCHITECT (Regd)	PRAWEEEN KUMAR MAHTO	
ENGINEER (Regd)		
SUPERVISOR (Regd)		
OWNER (Regd)	BABITA KUMARI	
DEVELOPMENT AUTHORITY	LOCAL BODY	

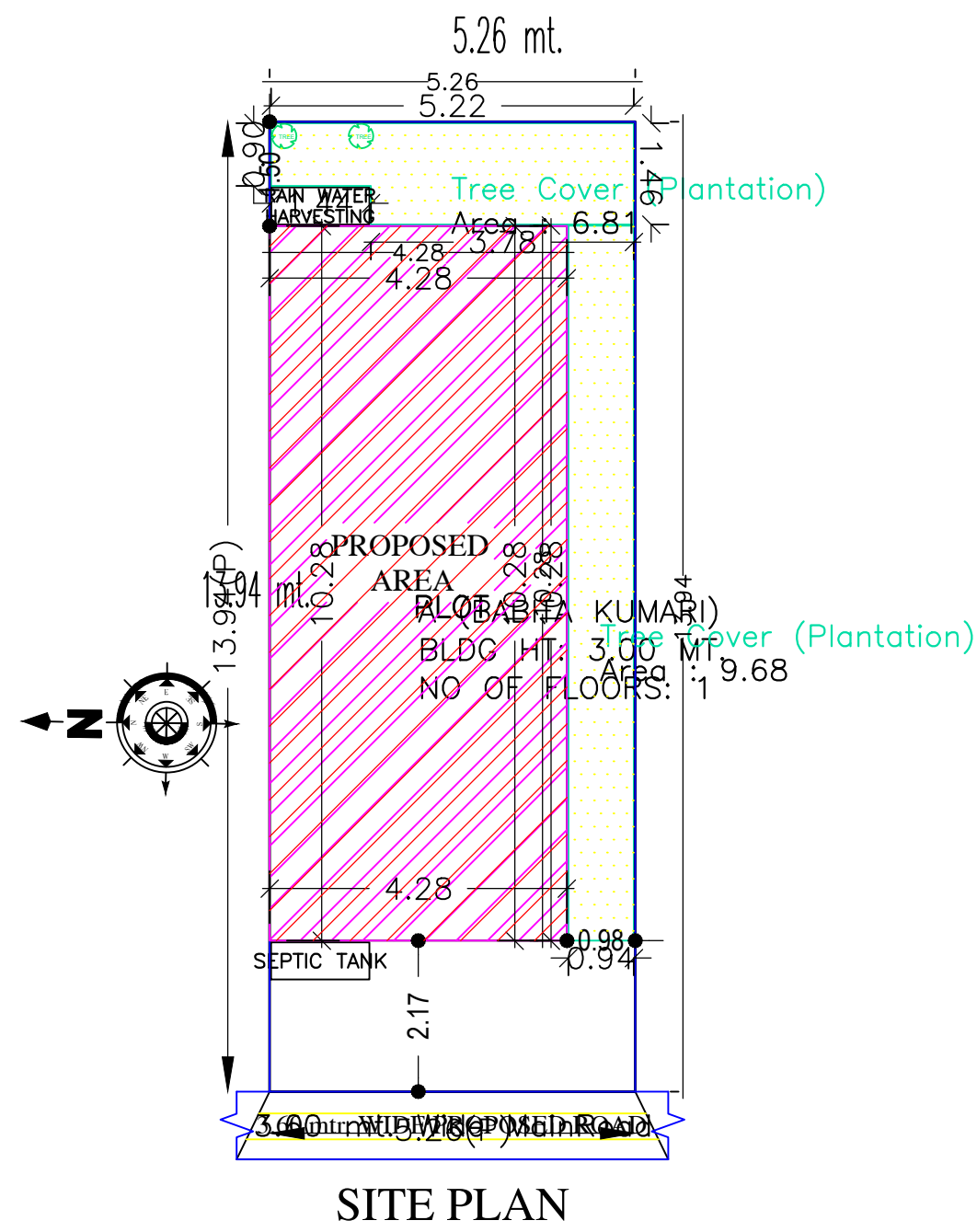

SITE PLAN

FAR & Tenement Details (Table 4c-1)

Building	No. of Same Bldg	Total Built Up Area (Sq.mt.)	Proposed FAR Area (Sq.mt.)	Total FAR Area (Sq.mt.)	Total Consumed Additional FAR Area (Sq.mt.)	Trmt (No.)
A (BABITA KUMARI)	1	43.93	43.93	43.93	43.93	01
Grand Total :	1	43.93	43.93	43.93	43.93	01

Building USE/SUBUSE Details

Building Name	Building Use	Building SubUse	Building Structure
A (BABITA KUMARI)	Residential	Bungalow/ Dwelling / Non Apartment	Non-Highrise

Buildingwise Floor FAR Details

Floor Name	Building Name		Total	
	Proposed Built Up Area (Sq.mt.)	Proposed FAR Area (Sq.mt.)	Total Proposed Built Up Area (Sq.mt.)	Total FAR Area (Sq.mt.)
Ground Floor	43.93	43.93	43.93	43.93
Terrace Floor	0.00	0.00	0.00	0.00
Total :	43.93	43.93	43.93	43.93

COLOR INDEX	
PLOT BOUNDARY	Black
ABUTTING ROAD	Green
PROPOSED CONSTRUCTION	Red
COMMON PLOT	Yellow
ROAD WIDENING AREA	Light Yellow
EXISTING (To be retained)	Blue
EXISTING (To be demolished)	Light Blue

LTP NAME AND SIGNATURE	STRUCTURAL ENG'S NAME AND SIGNATURE	BUILDER NAME AND SIGNATURE	DIGITAL SIGNATURE
PRAWEEEN KUMAR MAHTO MNP/ENG/0005/2020			

Proposal Basic Information	
Proposal File No.	MNP/IB/0003/W09/2023
Owner Name	BABITA KUMARI
Khata No	67
Plot No	0/1
Village Name	Madhupur Khas
Use	Residential
SubUse	Bungalow/ Dwelling / Non Apartment

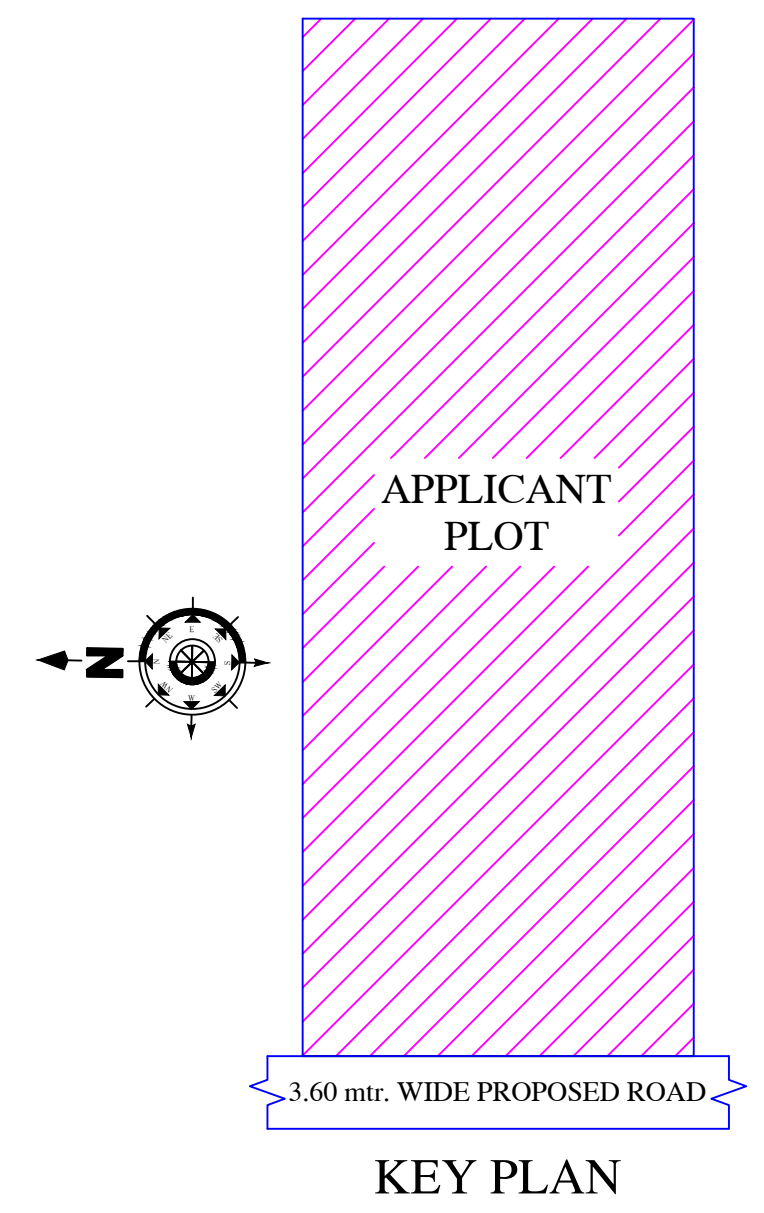
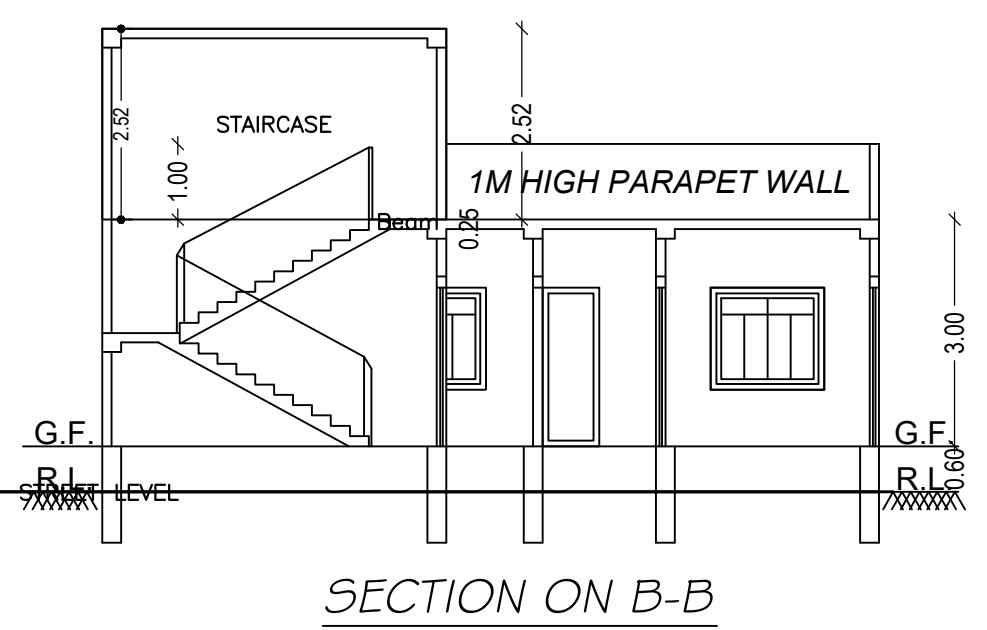
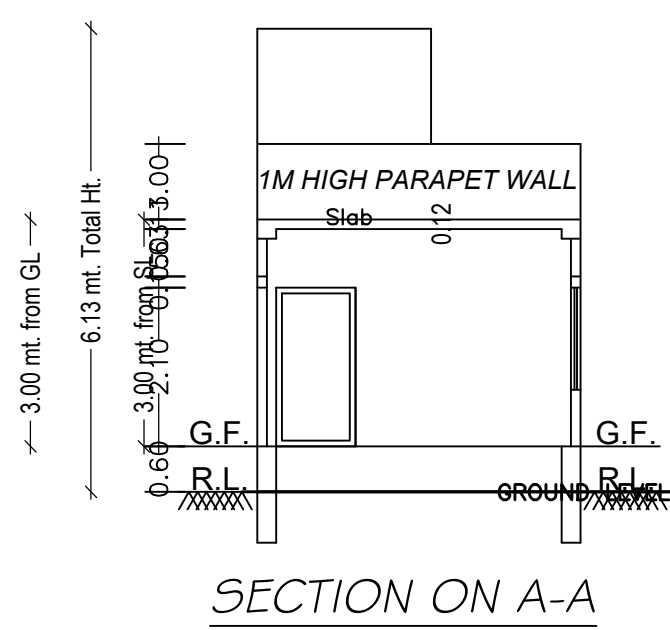
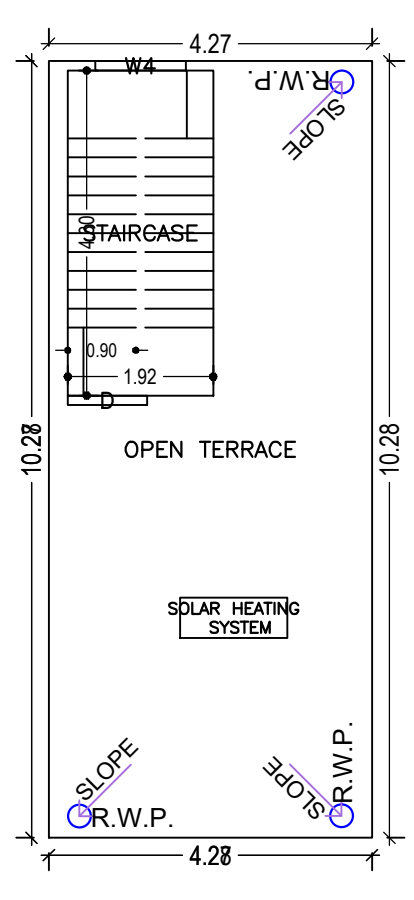
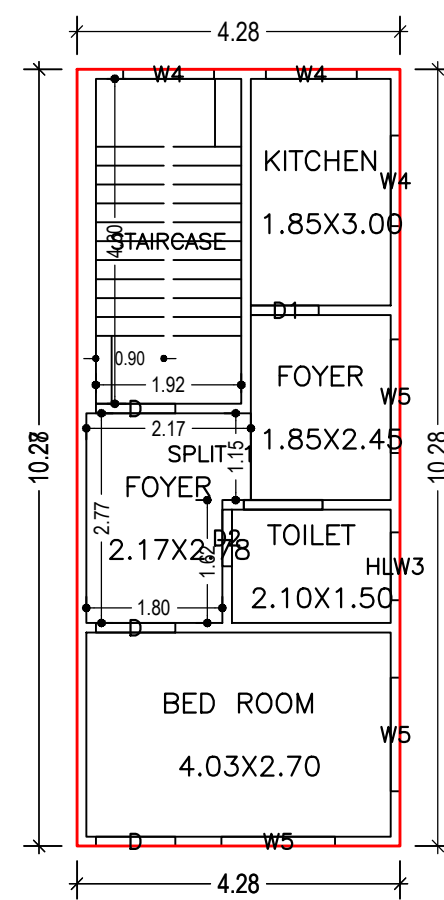

SCHEDULE OF DOOR:

BUILDING NAME	NAME	LENGTH	HEIGHT	NOS
A (BABITA KUMARI)	D2	0.75	2.10	01
A (BABITA KUMARI)	D1	0.90	2.10	01
A (BABITA KUMARI)	D	1.05	2.10	03

SCHEDULE OF WINDOW/VENTILATION:

BUILDING NAME	NAME	LENGTH	HEIGHT	NOS
A (BABITA KUMARI)	HLW3	0.90	0.60	01
A (BABITA KUMARI)	W4	1.20	1.35	04
A (BABITA KUMARI)	W5	1.50	1.35	03

Building :A (BABITA KUMARI)

Floor Name	Total Built Up Area (Sq.mt.)	Proposed FAR Area (Sq.mt.)	Total FAR Area (Sq.mt.)	Total Consumed Additional FAR Area (Sq.mt.)	Tnmt (No.)
Ground Floor	43.93	43.93	43.93	43.93	01
Terrace Floor	0.00	0.00	0.00	0.00	00
Total :	43.93	43.93	43.93	43.93	01
Total Number of Same Buildings :	1				
Total :	43.93	43.93	43.93	43.93	01

UnitBUA Table for Building :A (BABITA KUMARI)

FLOOR	Name	UnitBUA Type	UnitBUA Area	Carpet Area	No. of Rooms	No. of Tenement
GROUND FLOOR PLAN	SPLIT 1	FLAT	34.30	34.17	5	1
Total:	-	-	34.30	34.17	5	1

LTP NAME AND SIGNATURE	STRUCTURAL ENG'S NAME AND SIGNATURE	BUILDER NAME AND SIGNATURE	DIGITAL SIGNATURE
PRAWEEEN KUMAR MAHTO MNP/ENG/0005/2020			

Proposal Basic Information	
Proposal File No.	MNP/EP/0003/W09/2023
Owner Name	BABITA KUMARI
Khata No	67
Plot No	0/1
Village Name	Madhupur Khas
Use	Residential
SubUse	Bungalow/ Dwelling / Non Apartment

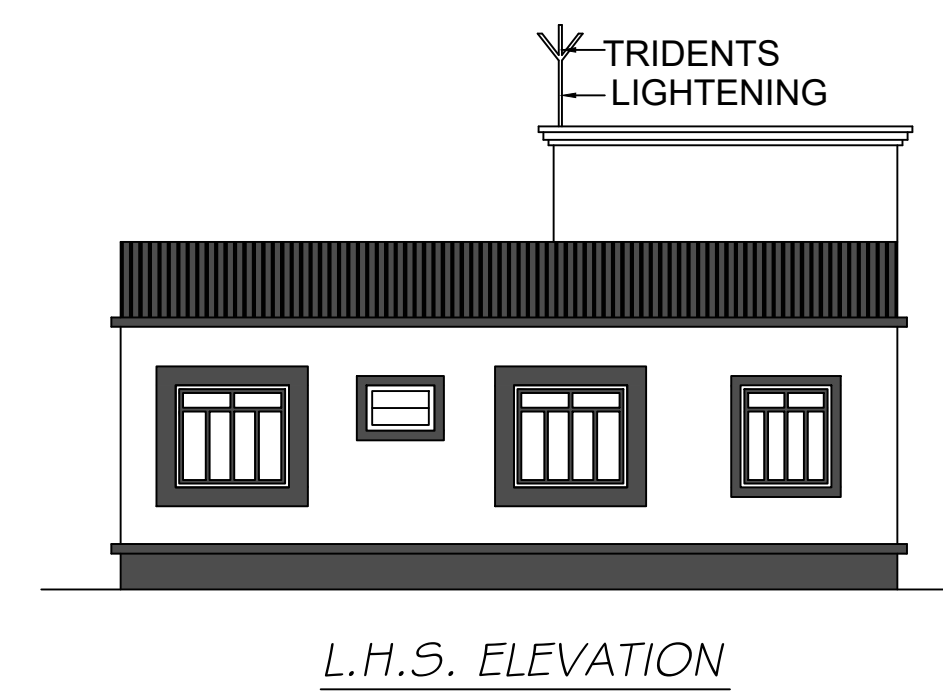
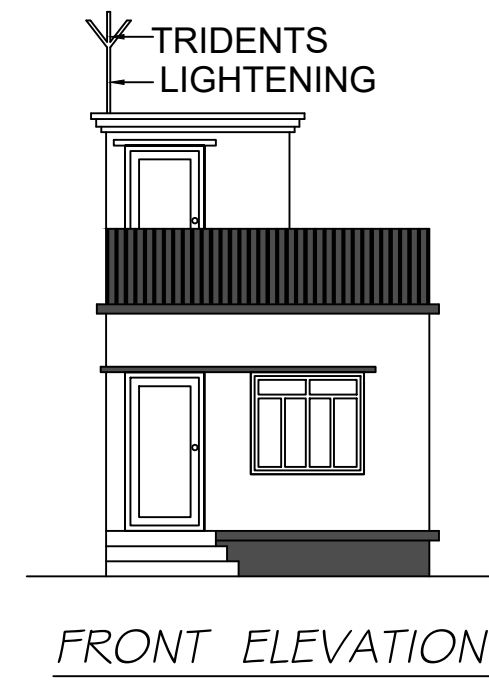
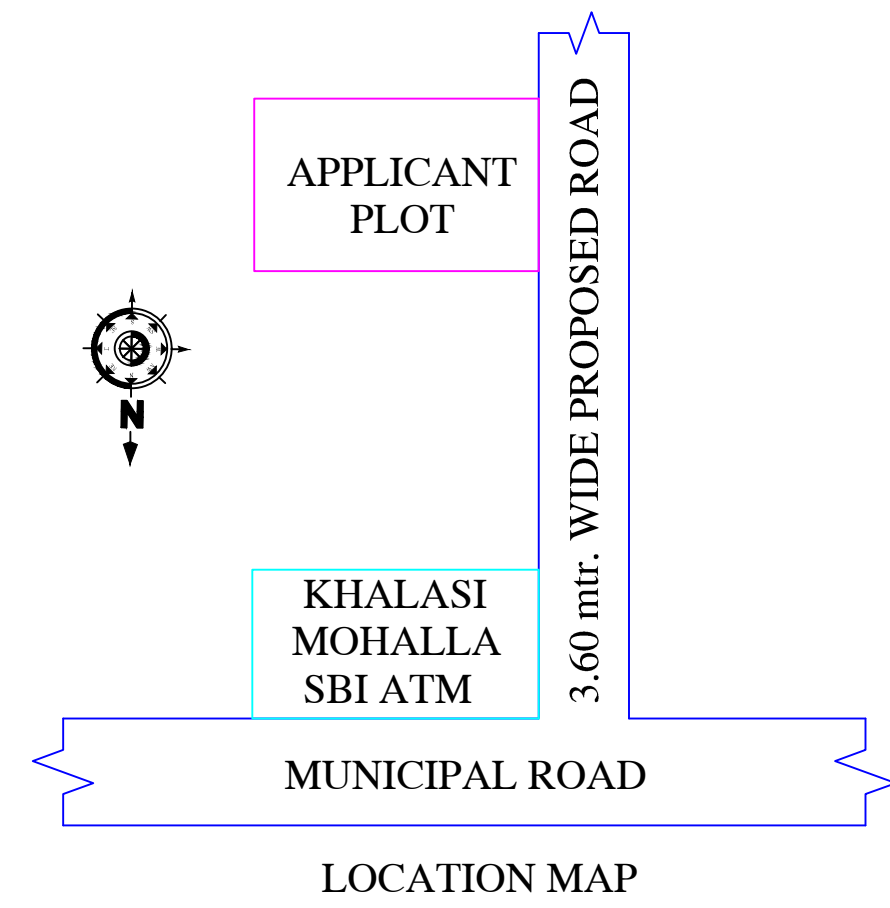
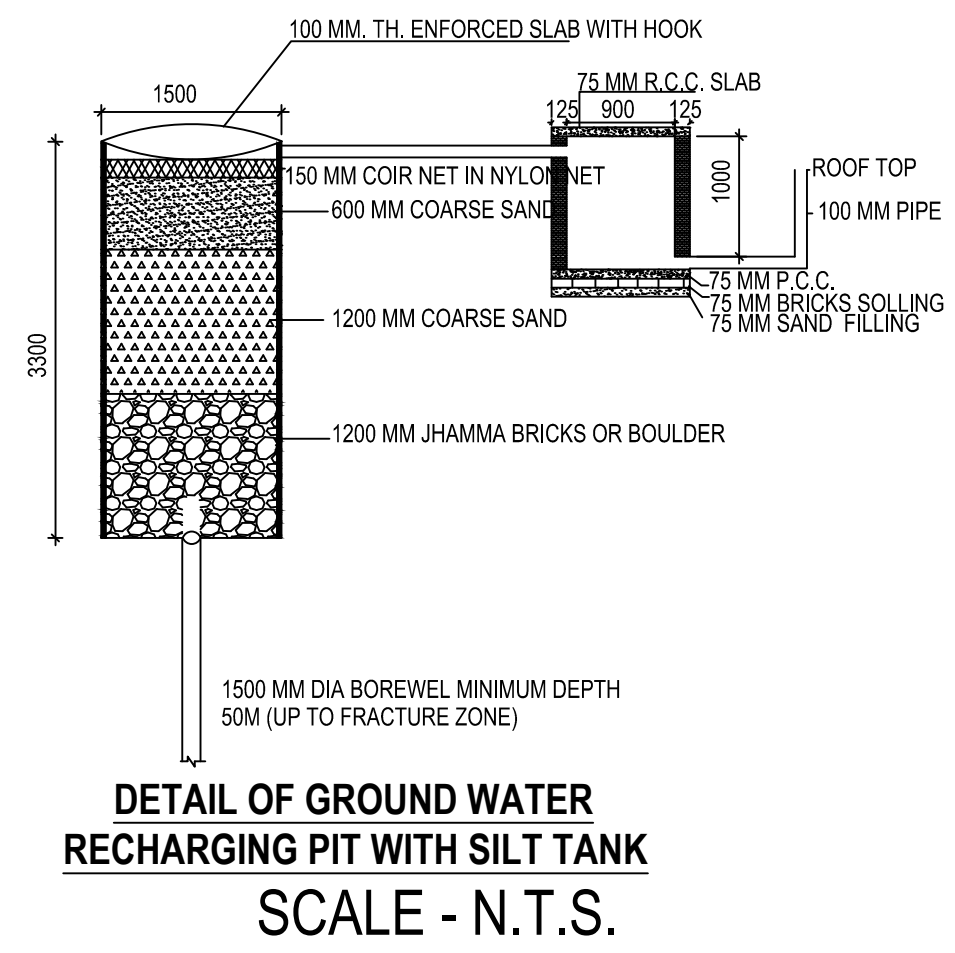
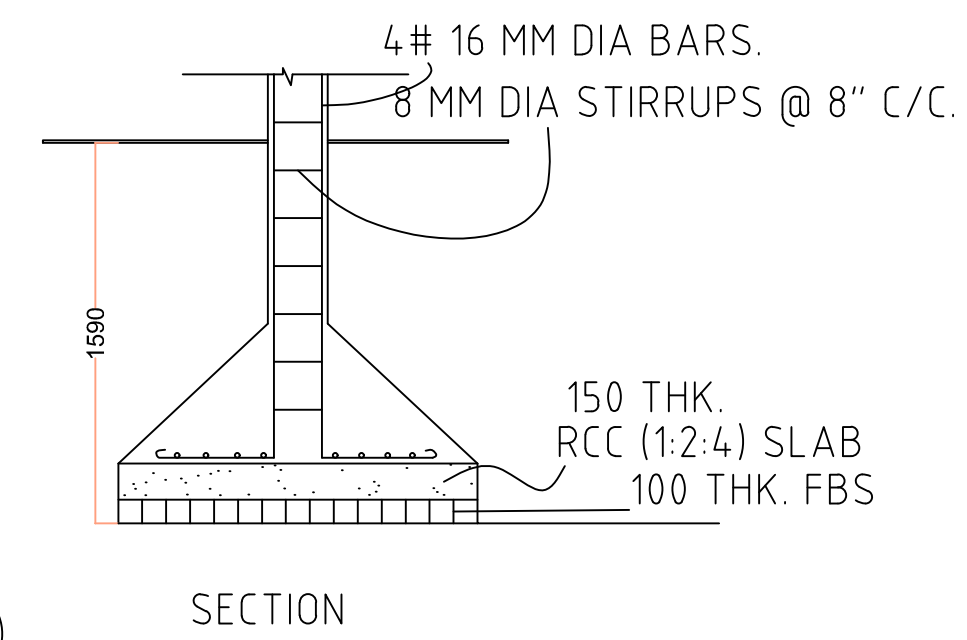
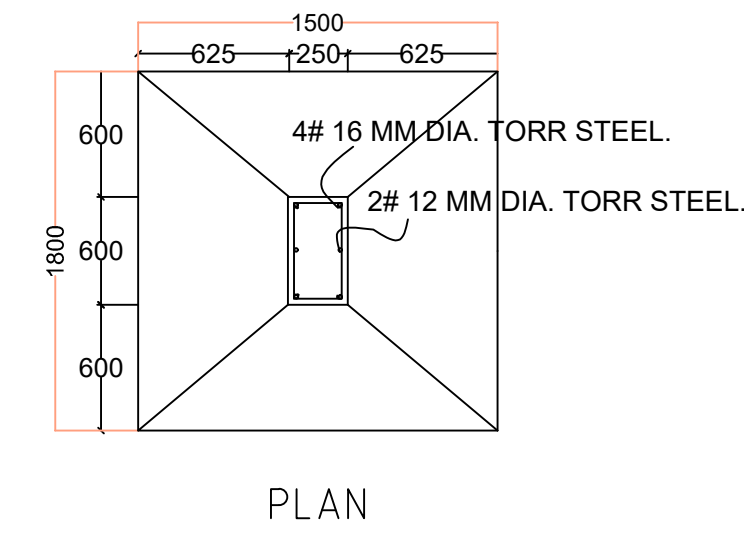
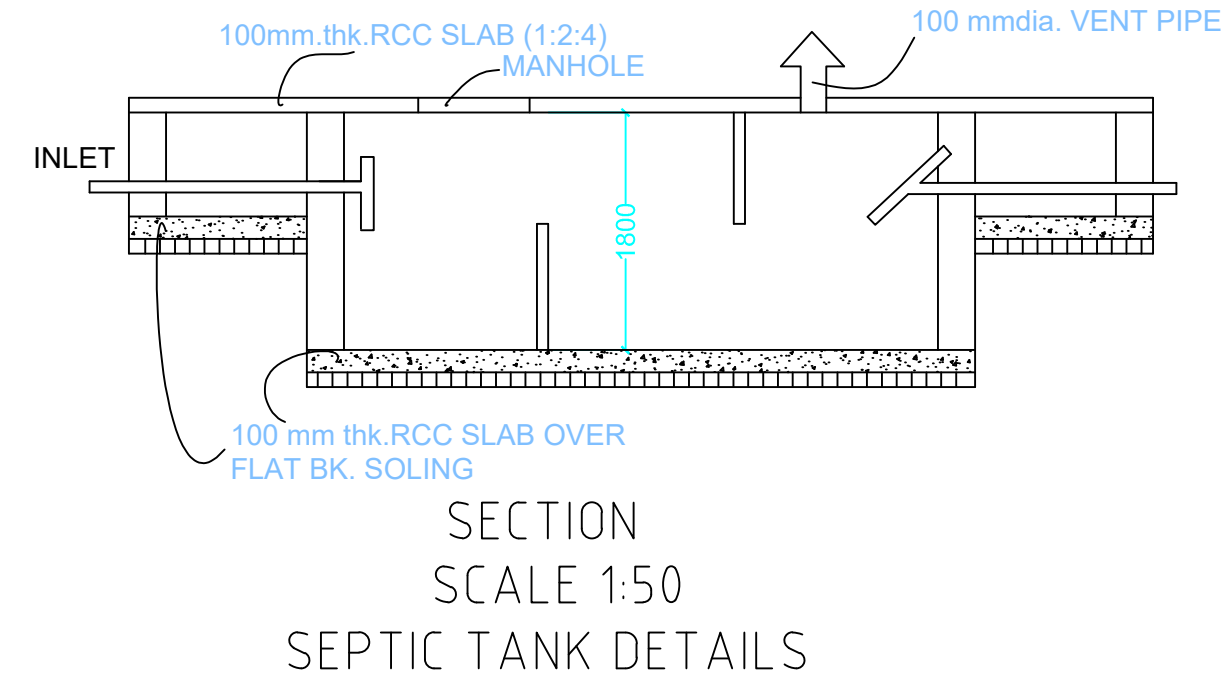
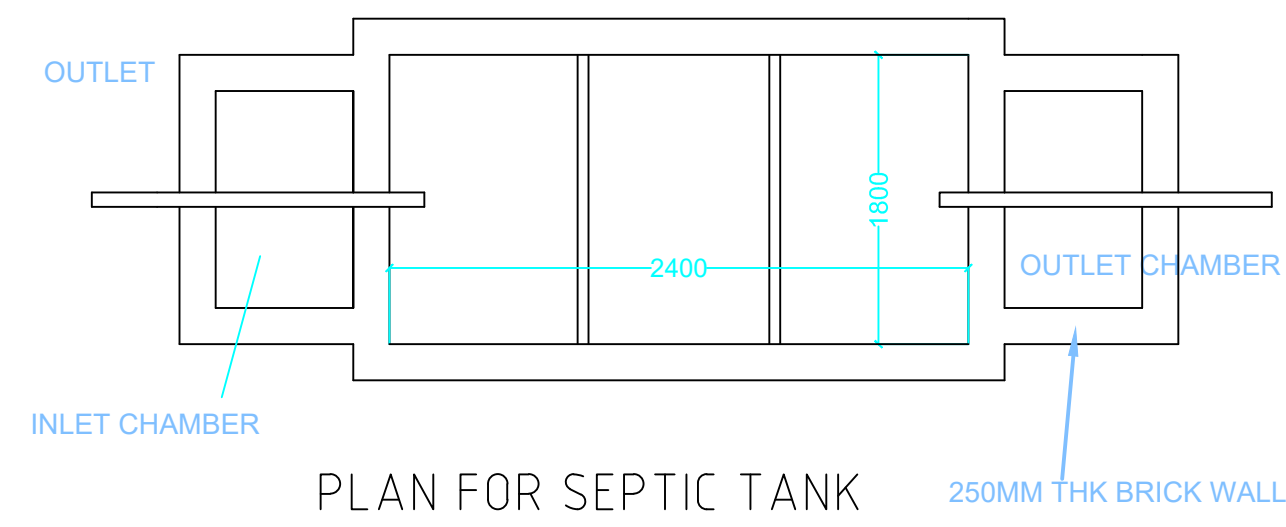

This is certify that the structure design is in accordance with the latest I-S code(I-S 875, I-S456-2002, I-S 1893-2000) for design & loading conditions (Seismic/wind/dead/live) and other all parameters are taken in account for safety of the structure.

LTP NAME AND SIGNATURE	STRUCTURAL ENG'S NAME AND SIGNATURE	BUILDER NAME AND SIGNATURE	DIGITAL SIGNATURE
PRAWEEEN KUMAR MAHTO MNP/ENG/0005/2020			