

Proposal Basic Information

Proposal File No.	MNP/BP/0028/W01/2023
Owner Name	AFTAB ALAM
Khata No	11 PART
Plot No	0/1
Village Name	Lakhna
Use	Residential
SubUse	Bungalow/ Dwelling / Non Apartment



AREA STATEMENT	VERSION NO.: 1.0.66
MADHUPUR NAGAR PARISHAD	VERSION DATE: 16/10/2020
PROJECT DETAIL:	
Region: JHARKHAND URBAN LOCAL BODIES	Plot Use: Residential
District: DEOGHAR	Plot SubUse: Bungalow/ Dwelling / Non Apartment
Authority: MADHUPUR NAGAR PARISHAD	PlotNearby/ReligiousStructure: NA
Inward No: MNP/BP/0028/W01/2023	PlotSubPlot No: 0/1
Application Type: General Proposal	North: Plot No. - LAND OF KHURSID ALAM
Project Type: Building Permission	South: Plot No. - LAND OF MANJUR MIA
Nature of Development: New	East: Road Width - 3.65
Location of Development Area: Old Area	West: Plot No. - LAND OF AKTARUL IMAN

AREA DETAILS:		SQ.MT.
AREA OF PLOT (Minimum)	(A)	104.29
NET AREA OF PLOT(Gross Plot Area - Deduction from Gross Plot area)	(A-Deductions)	104.29
Deduction for Balance Plot Area(from Gross Plot Area)		
Common Plot		10.74
Total		104.29
BALANCE AREA OF PLOT(Net Plot Area - Recreational/Amenity space)	(A-Deductions)	93.54
PLOT AREA FOR COVERAGE(Net Plot Area)	(A-Deductions)	104.29
Plot Area for FAR (Net Plot Area + RoadWidening Area)	(A-Deductions)	104.29

COVERAGE CHECK		
Permissible Coverage area (70.00 %)		73.00
Proposed Coverage Area (66.41 %)		69.26
Total Prop. Coverage Area (66.41 %)		69.26
Balance coverage area (3.59 %)		3.74
FAR CHECK		
Perm. FAR Area (1.500)		156.43
Total Perm. FAR area		156.43
Residential FAR		138.53
Proposed FAR Area		138.53
Total Proposed FAR Area		138.53
Consumed FAR (Factor)		1.33
Balance FAR Area		17.90

BUILT UP AREA CHECK	
Total Proposed BuiltUp Area	138.52
ARCHITECT (Regd)	SHAHNWAZ ASHRAF ANSARI
ENGINEER (Regd)	
SUPERVISOR (Regd)	
OWNER (Regd)	AFTAB ALAM
DEVELOPMENT AUTHORITY LOCAL BODY	

COLOR INDEX	
PLOT BOUNDARY	Black
ABUTTING ROAD	Red
PROPOSED CONSTRUCTION	Green
COMMON PLOT	Yellow
ROAD WIDENING AREA	Orange
EXISTING (To be retained)	Blue
EXISTING (To be demolished)	White

Buildingwise Floor FAR Details				
Floor Name	Building Name A (RESIDENTIAL BUILDING)		Total	
	Proposed Built Up Area (Sq.mt.)	Proposed FAR Area (Sq.mt.)	Total Proposed Built Up Area (Sq.mt.)	Total FAR Area (Sq.mt.)
Ground Floor	69.26	69.26	69.26	69.26
First Floor	69.26	69.26	69.26	69.26
Terrace Floor	0.00	0.00	0.00	0.00
Total :	138.52	138.52	138.52	138.52

Building USE/SUBUSE Details				
Building Name	Building Use	Building SubUse	Building Structure	
A (RESIDENTIAL BUILDING)	Residential	Bungalow/ Dwelling / Non Apartment	Non-Highrise	

FAR & Tenement Details (Table 4c-1)						
Building	No. of Same Bldg	Total Built Up Area (Sq.mt.)	Proposed FAR Area (Sq.mt.)	Total FAR Area (Sq.mt.)	Total Consumed Additional FAR Area (Sq.mt.)	Trmt (No.)
A (RESIDENTIAL BUILDING)	1	138.52	138.52	138.52	138.52	01
Grand Total :	1	138.52	138.52	138.52	138.52	01

UnitBUA Table for Building :A (RESIDENTIAL BUILDING)						
FLOOR	Name	UnitBUA Type	UnitBUA Area	Carpet Area	No. of Rooms	No. of Tenement
GROUND FLOOR PLAN	SPLIT A	FLAT	121.44	121.16	5	1
FIRST FLOOR PLAN	SPLIT A	FLAT	0.00	0.00	5	0
Total:	-	-	121.44	121.16	10	1

LTP NAME AND SIGNATURE	STRUCTURAL ENG'S NAME AND SIGNATURE	BUILDER NAME AND SIGNATURE	DIGITAL SIGNATURE
SHAHNWAZ ASHRAF ANSARI MNP/STU/0002/2022			

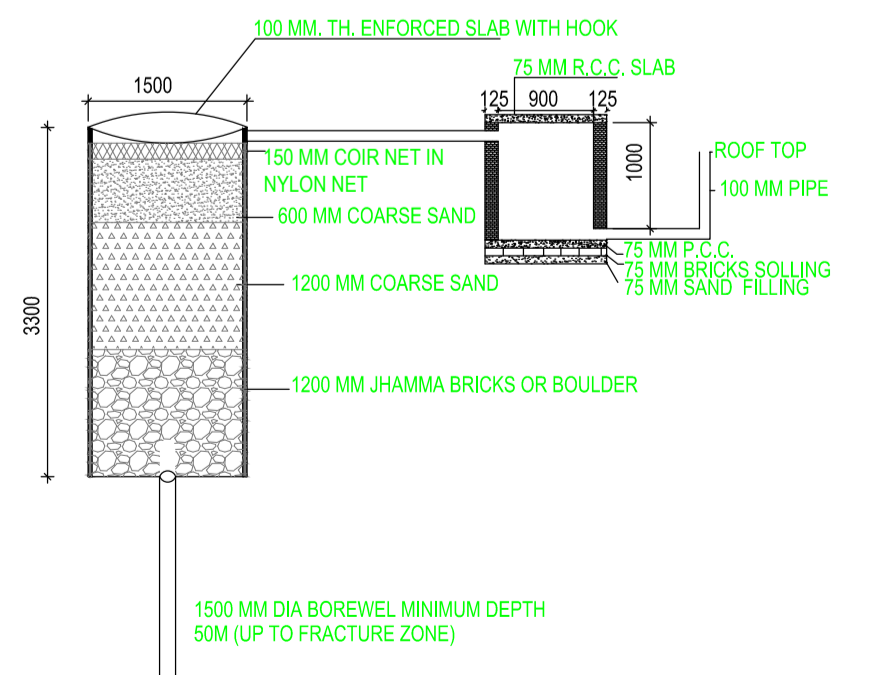
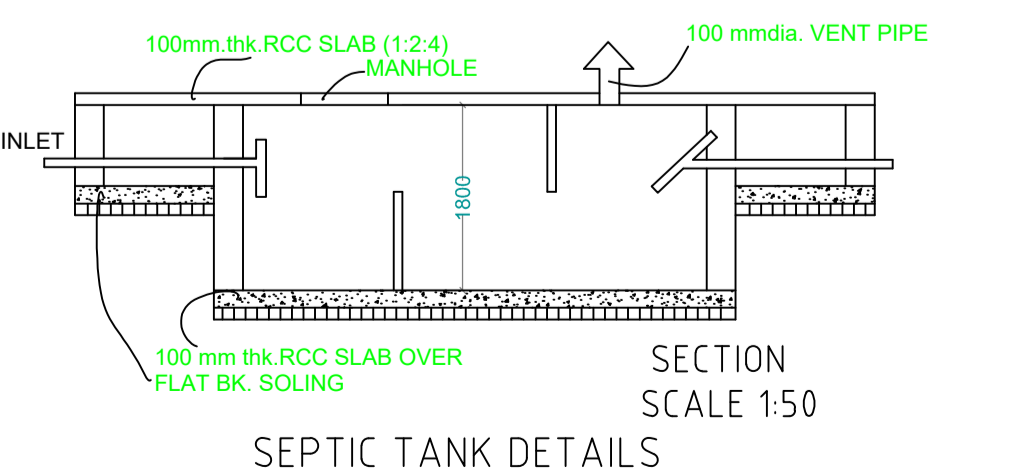
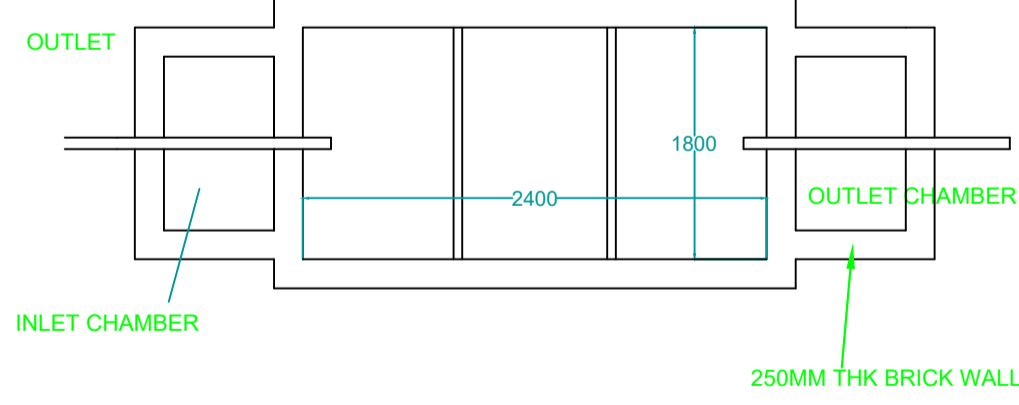
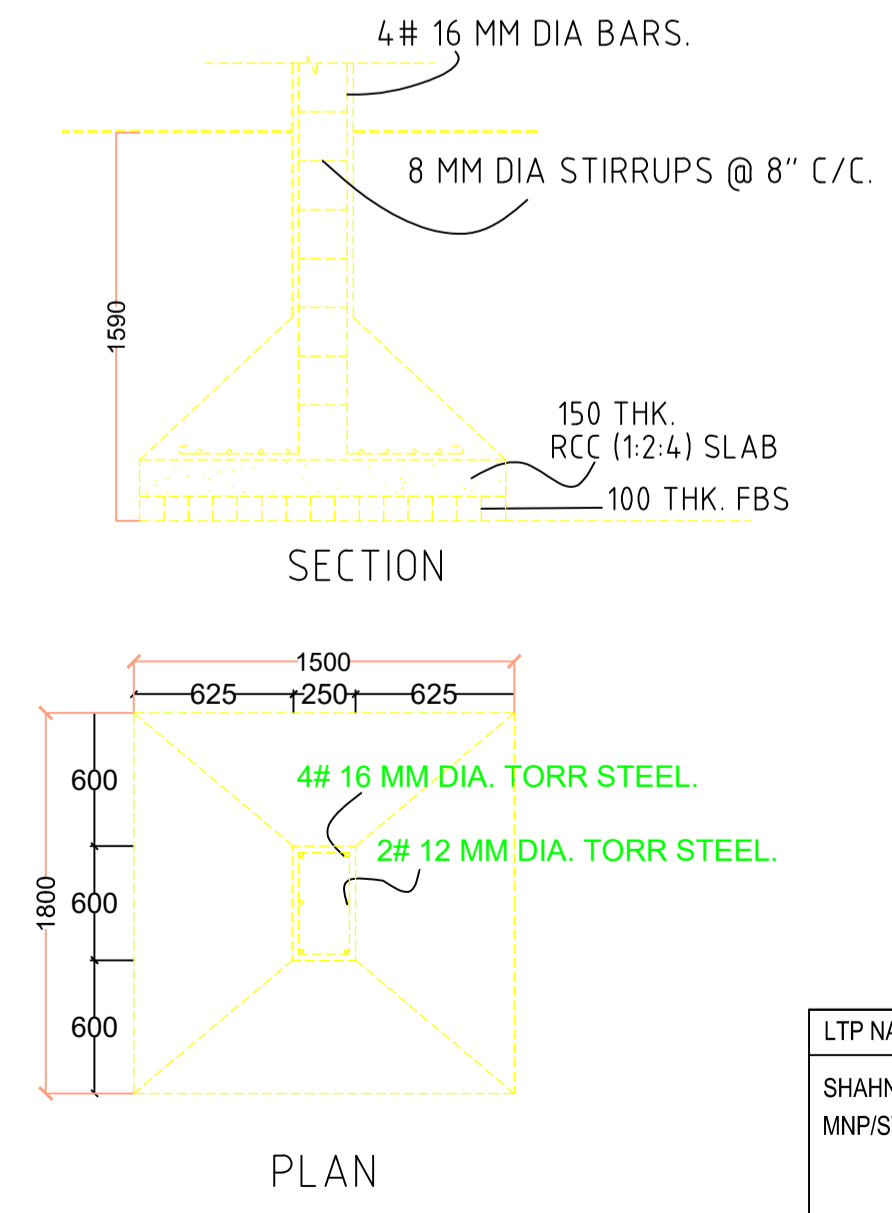
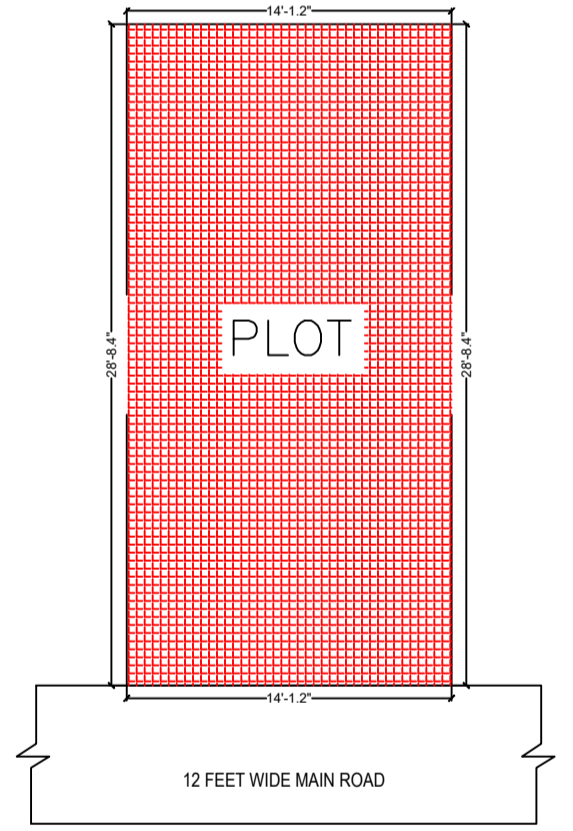
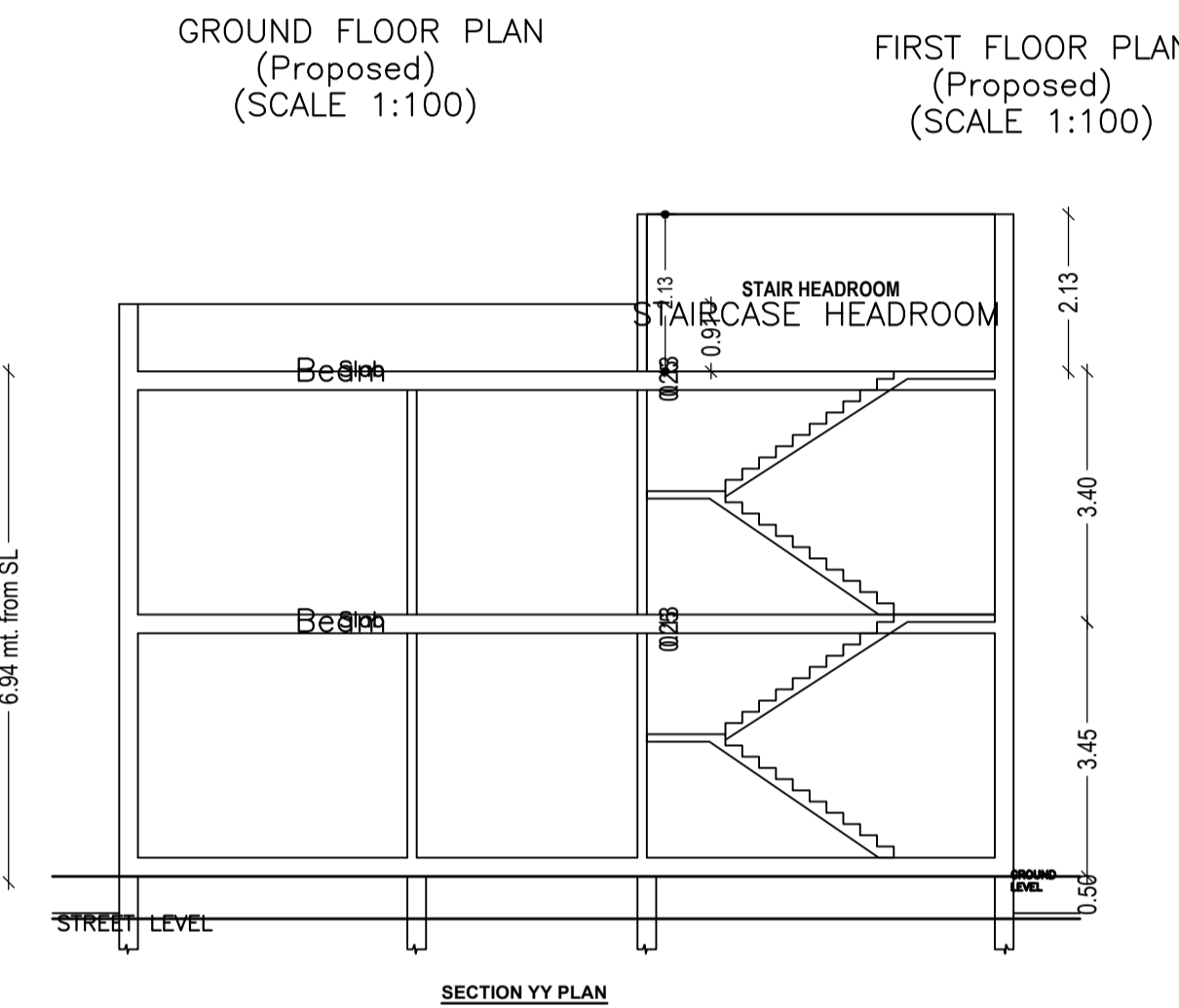
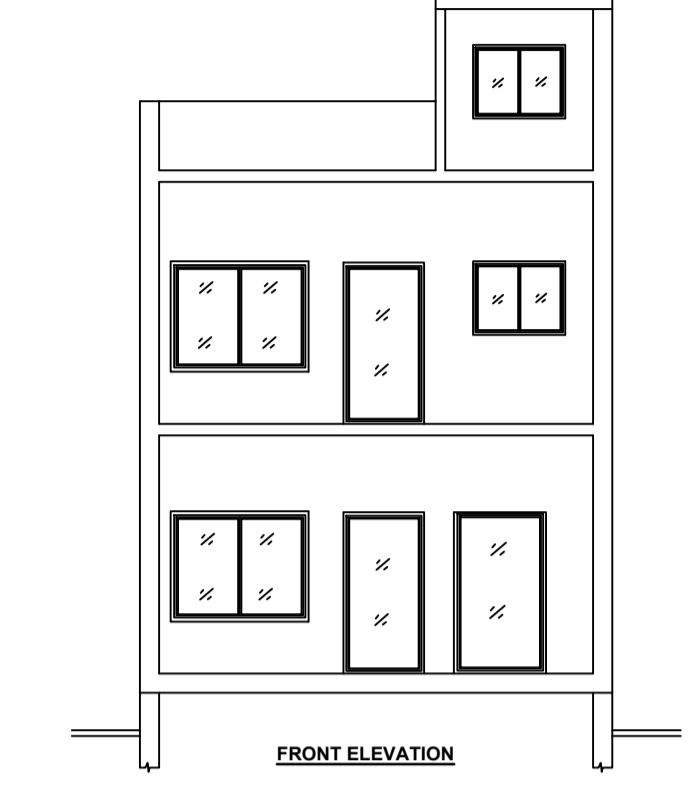
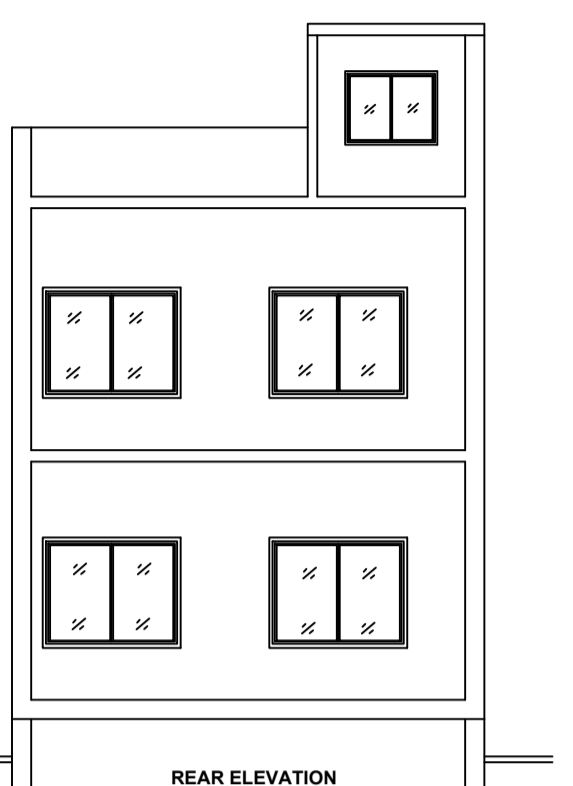
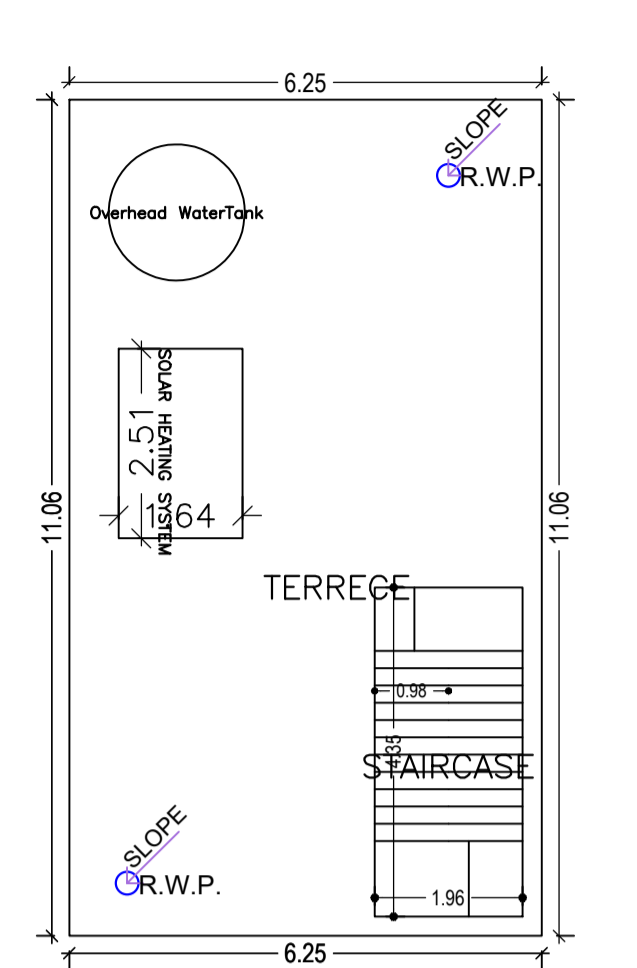
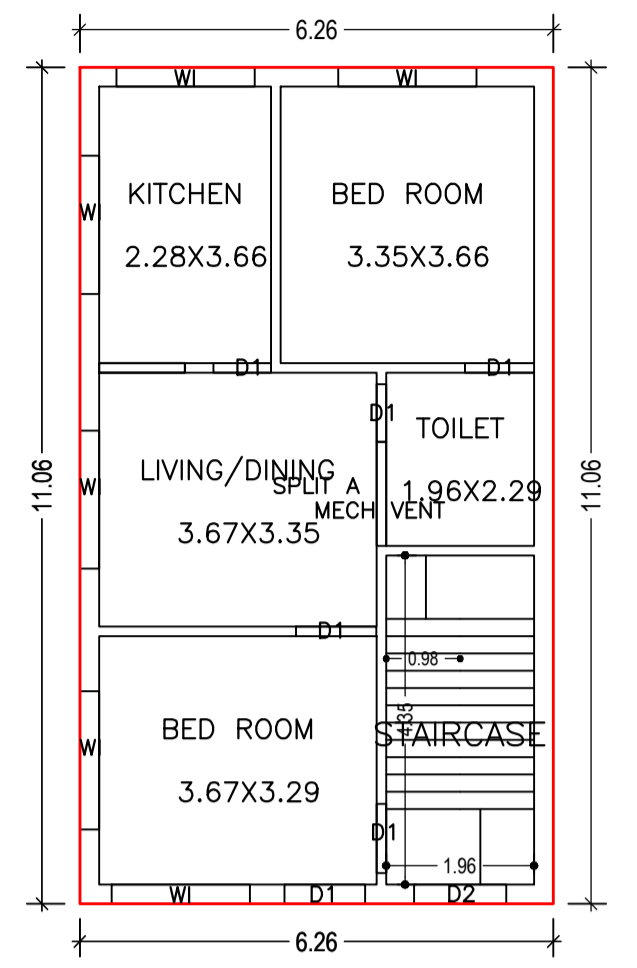
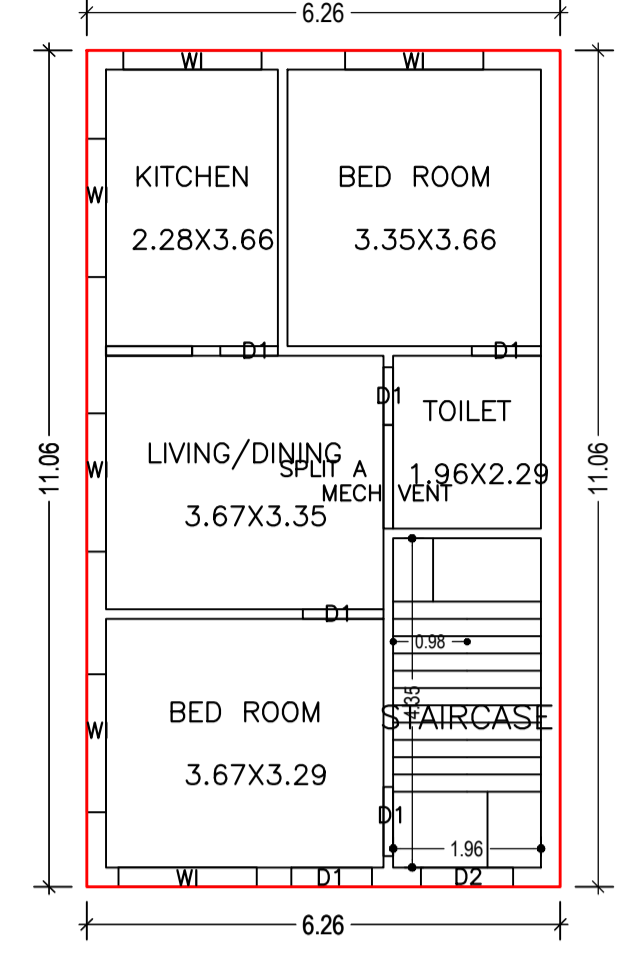
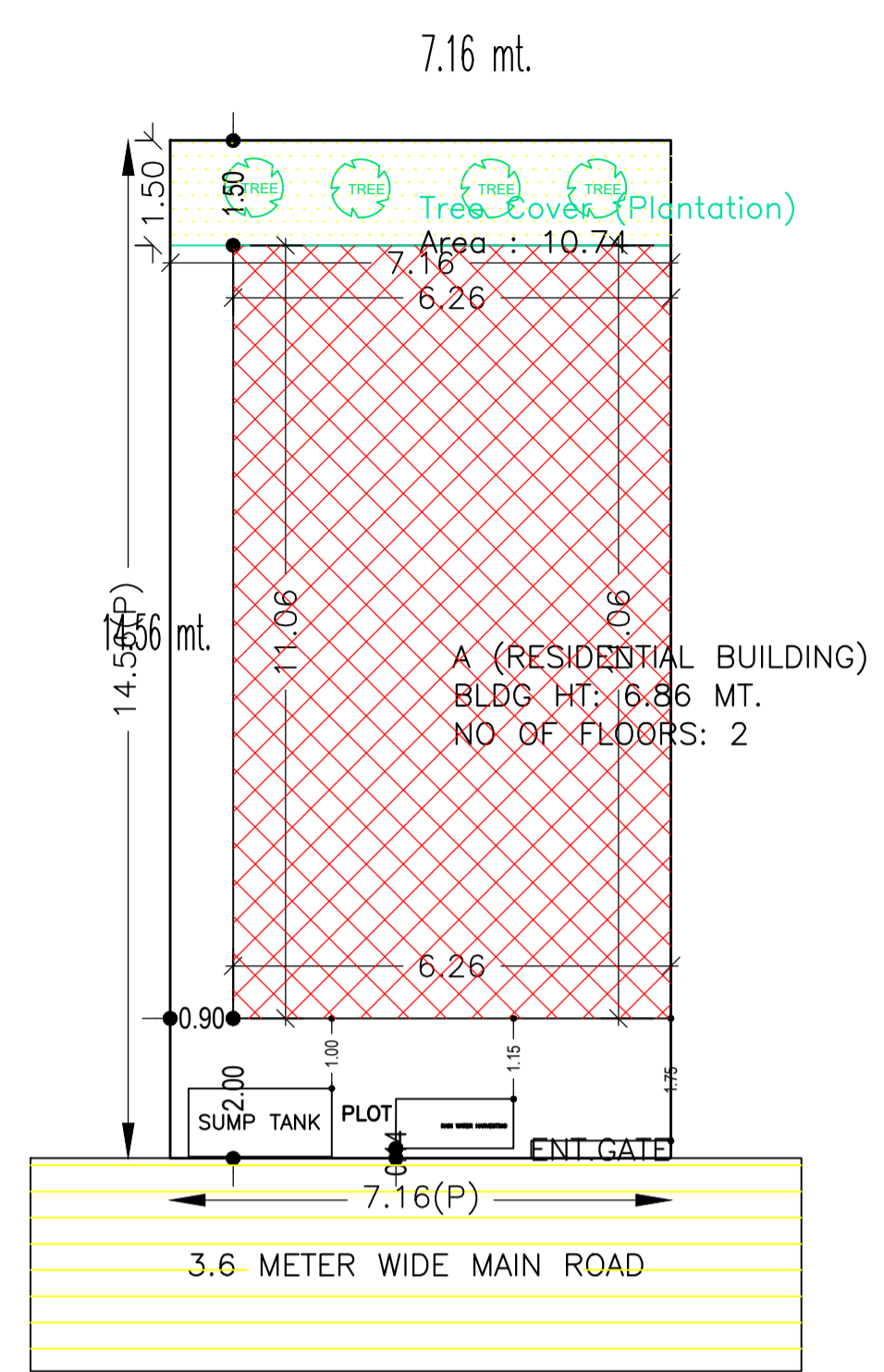

CERTIFICATE:
THIS IS CERTIFY THAT THE STRUCTURAL DESIGN OF THIS BUILDING IS AS PER IS CODE 189-1984 & 1903 TO MAKE THE SAME.

Building :A (RESIDENTIAL BUILDING)					
Floor Name	Total Built Up Area (Sq.mt.)	Proposed FAR Area (Sq.mt.)	Total FAR Area (Sq.mt.)	Total Consumed Additional FAR Area (Sq.mt.)	Trmt (No.)
Ground Floor	69.26	69.26	69.26	69.26	01
First Floor	69.26	69.26	69.26	69.26	00
Terrace Floor	0.00	0.00	0.00	0.00	00
Total :	138.52	138.52	138.52	138.52	01
Total Number of Same Buildings :	1				
Total :	138.52	138.52	138.52	138.52	01

SCHEDULE OF DOOR:				
BUILDING NAME	NAME	LENGTH	HEIGHT	NOS
A (RESIDENTIAL BUILDING)	D1	0.76	2.10	04
A (RESIDENTIAL BUILDING)	D1	0.91	2.10	04
A (RESIDENTIAL BUILDING)	D1	1.06	2.10	02
A (RESIDENTIAL BUILDING)	D1	1.07	2.10	02

SCHEDULE OF WINDOW/VENTILATION:				
BUILDING NAME	NAME	LENGTH	HEIGHT	NOS
A (RESIDENTIAL BUILDING)	MECH VENT	1.37	1.20	02
A (RESIDENTIAL BUILDING)	WI	1.83	1.20	12