

SITE PLAN

AREA STATEMENT MADHUPUR NAGAR PARISHAD	VERSION NO.: 1.0.66 VERSION DATE: 16/10/2020
PROJECT DETAIL:	
Region: JHARKHAND URBAN LOCAL BODIES	Plot Use: Residential
District: DEOGHAR	Plot SubUse: Bungalow/ Dwelling / Non Apartment
Authority: MADHUPUR NAGAR PARISHAD	PlotNearby/ReligiousStructure: NA
Inward_No: MNP/IBP/0016/W09/2023	Plot/SubPlot No: 0/1
Application Type: General Proposal	North: Road Width - 9.14
Project Type: Building Permission	South: Plot No. - LAND OF CHOTAN ANSHARI
Nature of Development: New	East: Plot No. - LAND OF CHOTAN ANSHARI
Location of Development Area: Old Area	West: Plot No. - VENDORS LAND
AREA DETAILS:	
AREA OF PLOT (Minimum)	(A) 27.86 SQ.MT.
NET AREA OF PLOT(Gross Plot Area - Deduction from Gross Plot area)	(A-Deductions) 27.86
Deduction for Balance Plot Area(from Gross Plot Area)	
Common Plot	8.59
Total	8.59
BALANCE AREA OF PLOT(Net Plot Area - Recreational/Amenity space)	(A-Deductions) 19.27
PLOT AREA FOR COVERAGE(Net Plot Area)	(A-Deductions) 27.86
Plot Area for FAR (Net Plot Area + RoadWidening Area)	(A-Deductions) 27.86
COVERAGE CHECK	
Permissible Coverage area ( 70.00 % )	19.50
Proposed Coverage Area ( 64.11 % )	17.86
Total Prop. Coverage Area ( 64.11 % )	17.86
Balance coverage area ( 5.89 % )	1.64
FAR CHECK	
Perm. FAR Area ( 2.000 )	55.72
Total Perm. FAR area	55.72
Residential FAR	17.86
Proposed FAR Area	25.18
Total Proposed FAR Area	25.18
Consumed FAR (Factor)	0.90
Balance FAR Area	30.54
BUILT UP AREA CHECK	
Total Proposed BuiltUp Area	35.72
ARCHITECT (Regd)	PRAWEEEN KUMAR MAHTO
ENGINEER (Regd)	
SUPERVISOR (Regd)	
OWNER (Regd)	MOON DEVI
DEVELOPMENT AUTHORITY LOCAL BODY	

Proposal Basic Information	
Proposal File No.	MNP/IBP/0016/W09/2023
Owner Name	MOON DEVI
Khata No	173/B
Plot No	0/1
Village Name	Madhupur Bazar
Use	Residential
SubUse	Bungalow/ Dwelling / Non Apartment

Building USE/SUBUSE Details

Building Name	Building Use	Building SubUse	Building Structure
A (MOON DEVI)	Residential	Bungalow/ Dwelling / Non Apartment	Non-Highrise

SITE PLAN

FAR & Tenement Details (Table 4c-1)

Building	No. of Same Bldg	Total Built Up Area (Sq.mt.)	Deductions (Area in Sq.mt.)		Proposed FAR Area (Sq.mt.)	Add Area In FAR (Sq.mt.)	Total FAR Area (Sq.mt.)	Total Consumed Additional FAR Area (Sq.mt.)	Tnmt (No.)
			Parking	Resi.					
A (MOON DEVI)	1	35.72	10.55	17.86	7.31	25.17	25.17	01	
Grand Total :	1	35.72	10.55	17.86	7.31	25.17	25.17	01	

Buildingwise Floor FAR Details

Floor Name	Building Name A (MOON DEVI)		Total	
	Proposed Built Up Area (Sq.mt.)	Proposed FAR Area (Sq.mt.)	Total Proposed Built Up Area (Sq.mt.)	Total FAR Area (Sq.mt.)
Ground Floor	17.86	7.31	17.86	7.31
First Floor	17.86	17.86	17.86	17.86
Terrace Floor	0.00	0.00	0.00	0.00
Total :	35.72	25.17	35.72	25.17

COLOR INDEX	
PLOT BOUNDARY	Black
ABUTTING ROAD	Green
PROPOSED CONSTRUCTION	Red
COMMON PLOT	Yellow
ROAD WIDENING AREA	Blue
EXISTING (To be retained)	Blue
EXISTING (To be demolished)	Yellow

LTP NAME AND SIGNATURE	STRUCTURAL ENG'S NAME AND SIGNATURE	BUILDER NAME AND SIGNATURE	DIGITAL SIGNATURE
PRAWEEEN KUMAR MAHTO MNP/ENG/0005/2020			

Proposal Basic Information	
Proposal File No.	MNP/ENG/0016/W09/2023
Owner Name	MOON DEVI
Khata No	173/B
Plot No	0/1
Village Name	Madhupur Bazar
Use	Residential
SubUse	Bungalow/ Dwelling / Non Apartment

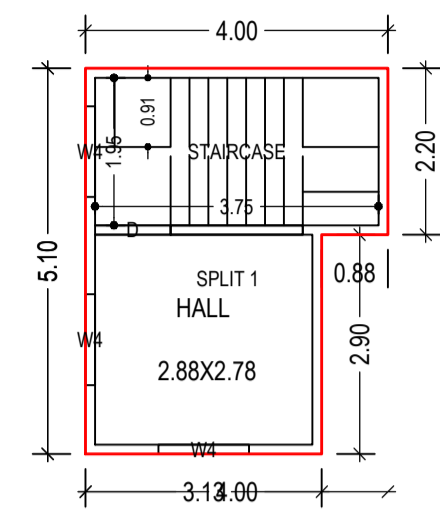

FIRST FLOOR PLAN  
(Proposed)  
(SCALE 1:100)

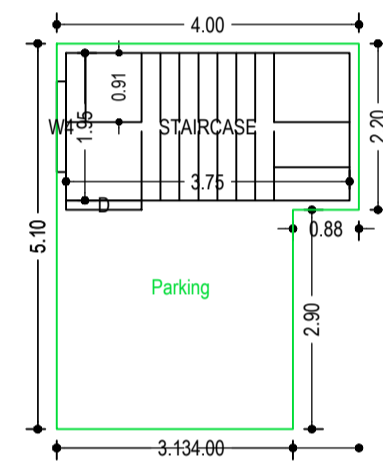

GROUND FLOOR PLAN  
(SCALE 1:100)

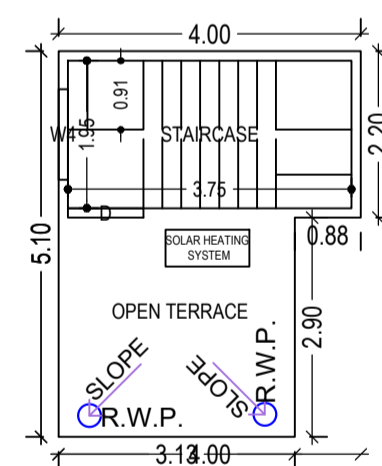

TERRACE FLOOR PLAN  
(SCALE 1:100)

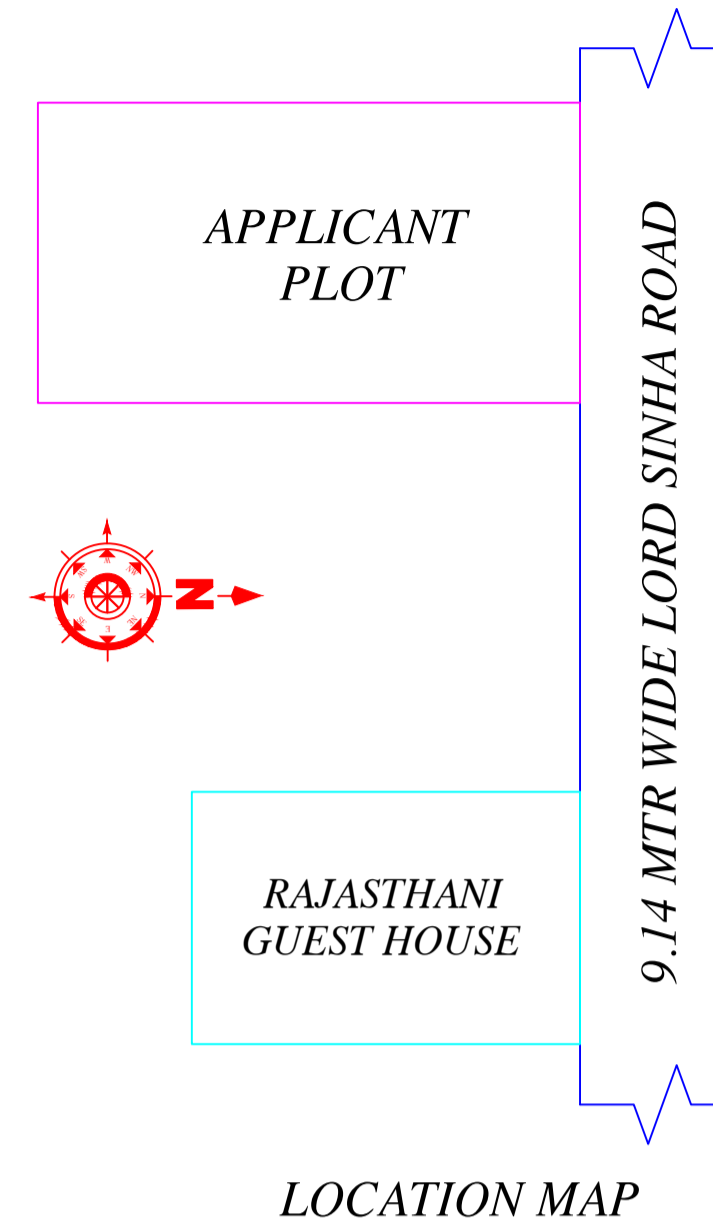
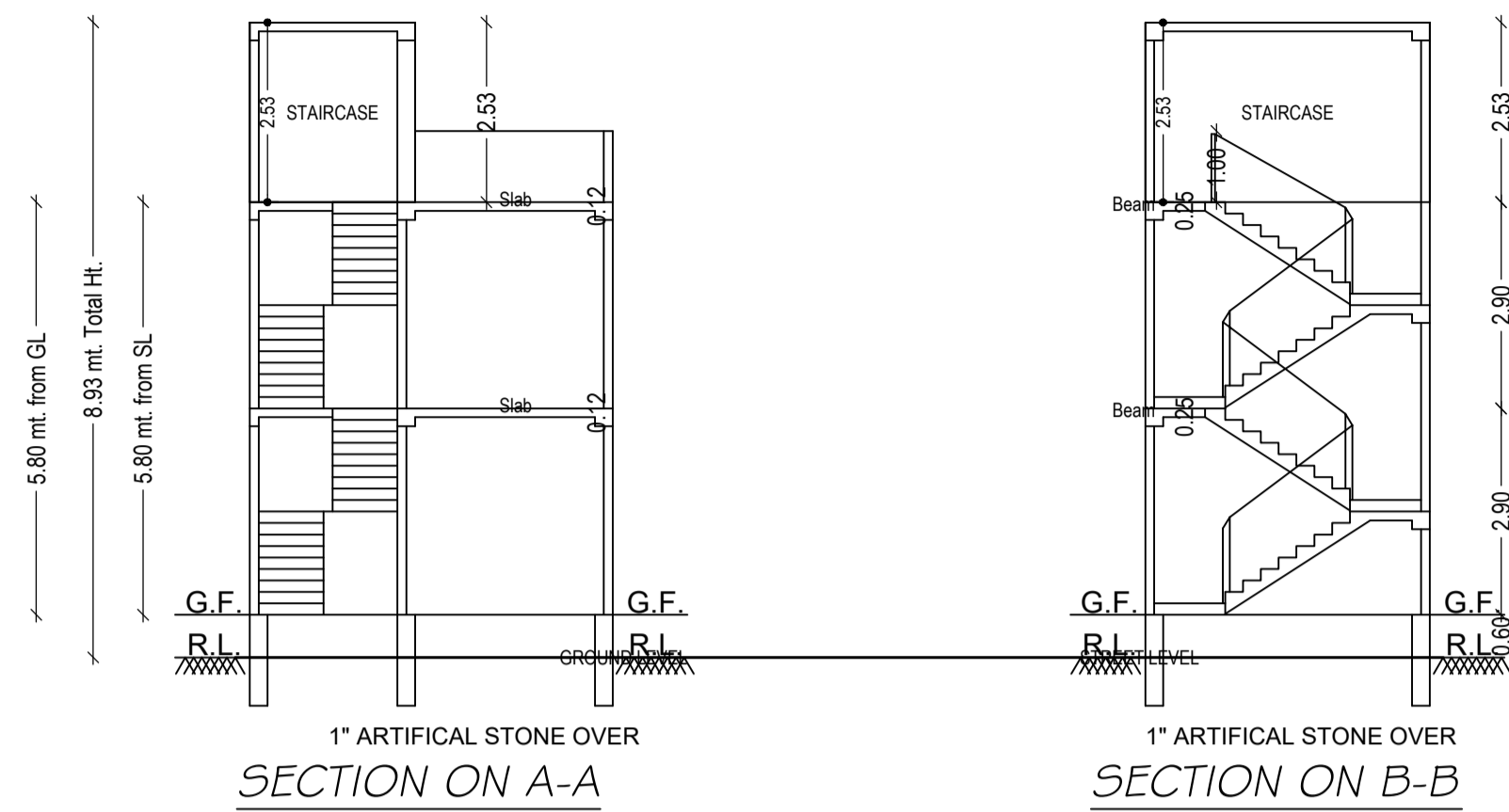

LOCATION MAP

UnitBUA Table for Building :A (MOON DEVI)

FLOOR	Name	UnitBUA Type	UnitBUA Area	Carpel Area	No. of Rooms	No. of Tenement
FIRST FLOOR PLAN	SPLIT 1	FLAT	9.45	9.23	1	1
Total:	-	-	9.45	9.23	1	1

SCHEDULE OF DOOR:

BUILDING NAME	NAME	LENGTH	HEIGHT	NOS
A (MOON DEVI)	D	1.00	2.10	01

SCHEDULE OF WINDOW/VENTILATION:

BUILDING NAME	NAME	LENGTH	HEIGHT	NOS
A (MOON DEVI)	W4	1.20	1.35	05

Building :A (MOON DEVI)

Floor Name	Total Built Up Area (Sq.mt.)	Deductions (Area in Sq.mt.)		Proposed FAR Area (Sq.mt.)	Add Area in FAR (Sq.mt.)	Total FAR Area (Sq.mt.)	Total Consumed Additional FAR Area (Sq.mt.)	Tnmt (No.)
		Parking	Resi.					
Ground Floor	17.86	10.55	0.00	7.31	7.31	7.31	00	
First Floor	17.86	0.00	17.86	0.00	17.86	17.86	01	
Terrace Floor	0.00	0.00	0.00	0.00	0.00	0.00	00	
Total:	35.72	10.55	17.86	7.31	25.17	25.17	01	
Total Number of Same Buildings	1							
Total :	35.72	10.55	17.86	7.31	25.17	25.17	01	

LTP NAME AND SIGNATURE	STRUCTURAL ENG'S NAME AND SIGNATURE	BUILDER NAME AND SIGNATURE	DIGITAL SIGNATURE
PRAWEEEN KUMAR MAHTO MNP/ENG/0005/2020			

Proposal Basic Information	
Proposal File No.	MNP/EP/0016/W09/2023
Owner Name	MOON DEVI
Khata No	173/B
Plot No	0/1
Village Name	Madhupur Bazar
Use	Residential
SubUse	Bungalow/ Dwelling / Non Apartment

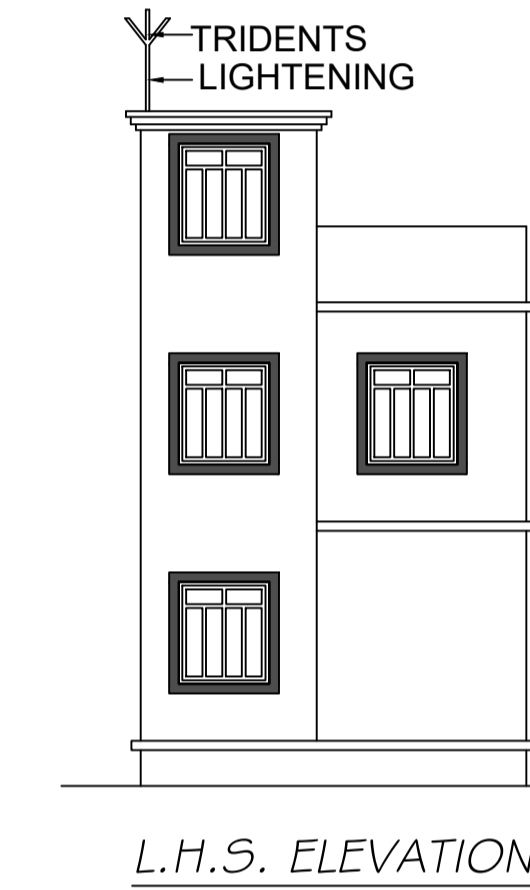
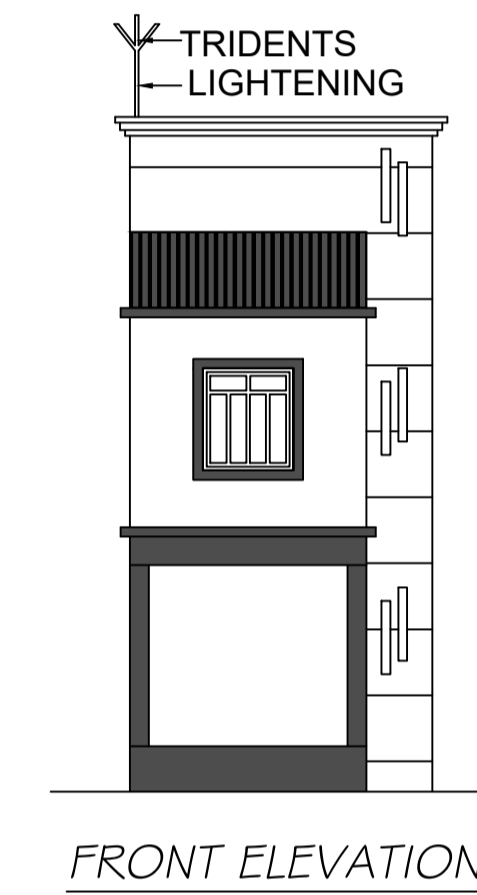
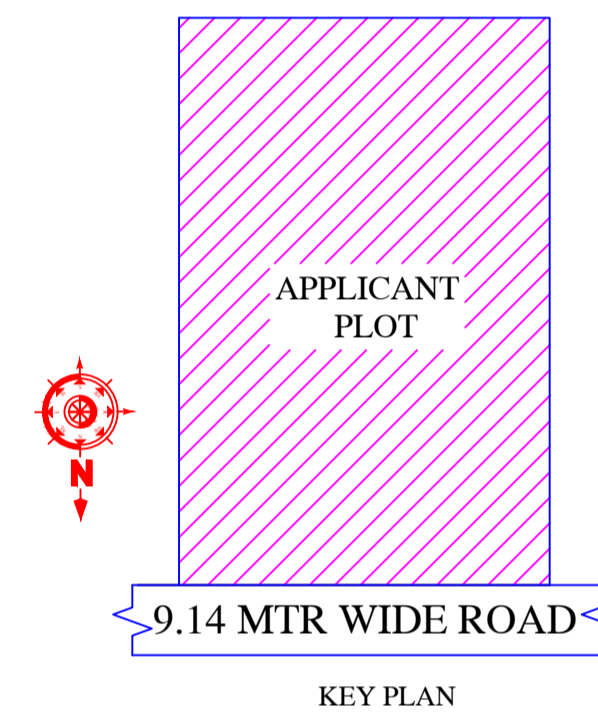
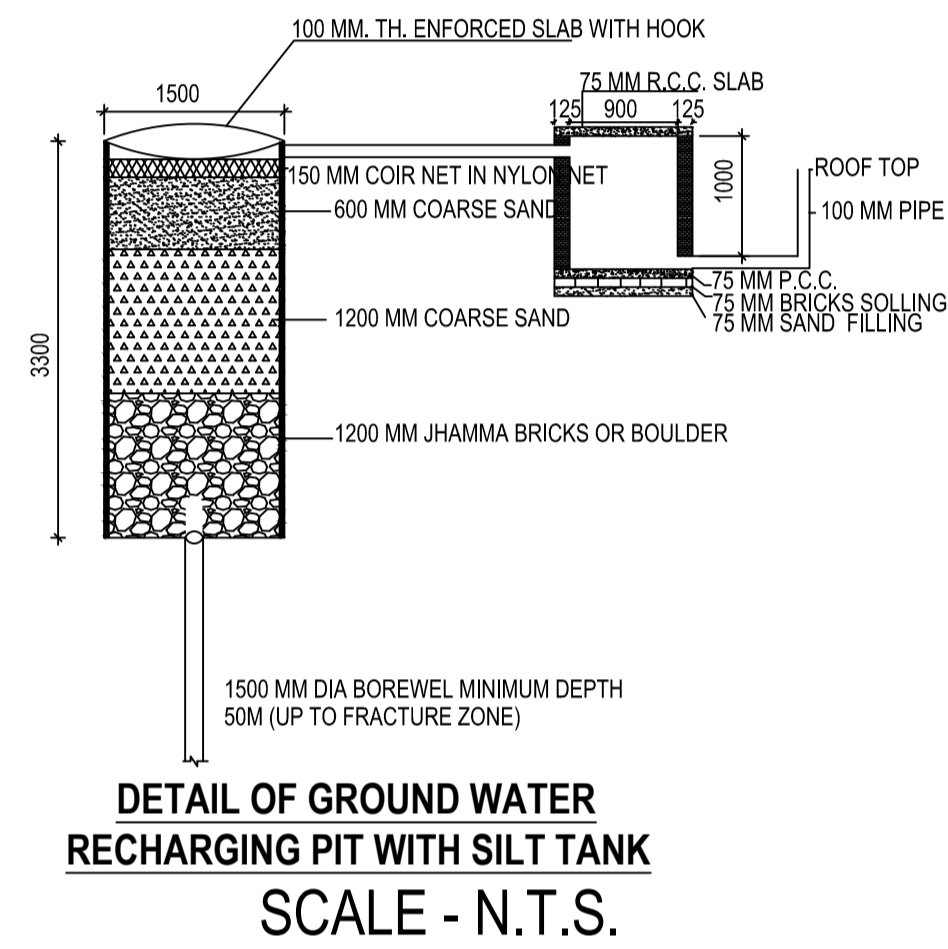
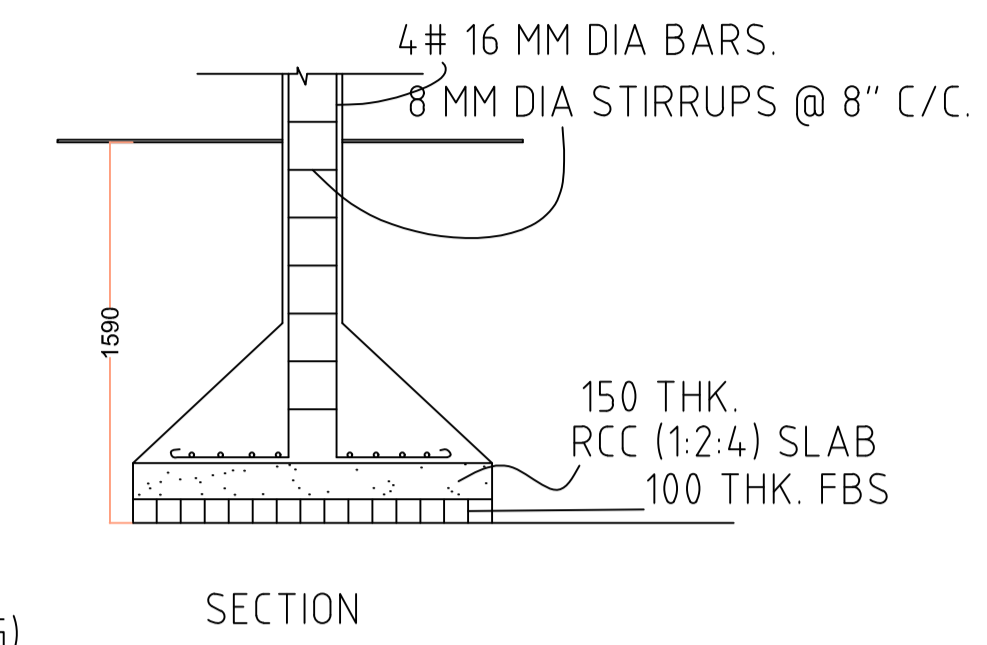
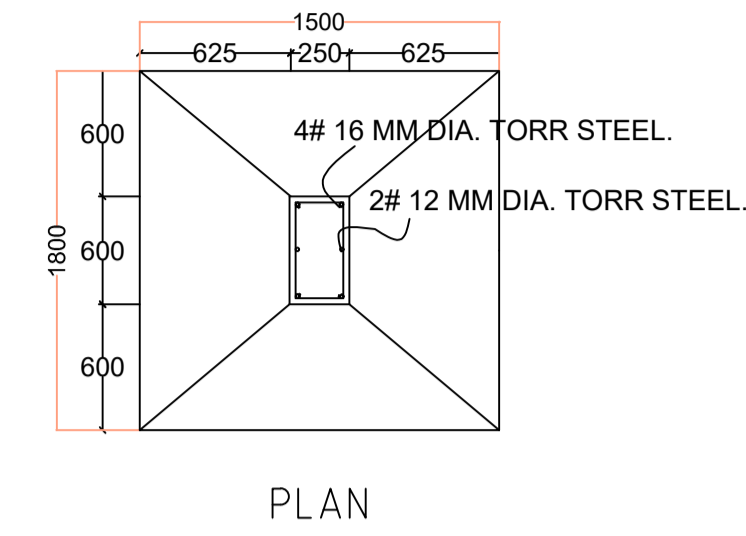
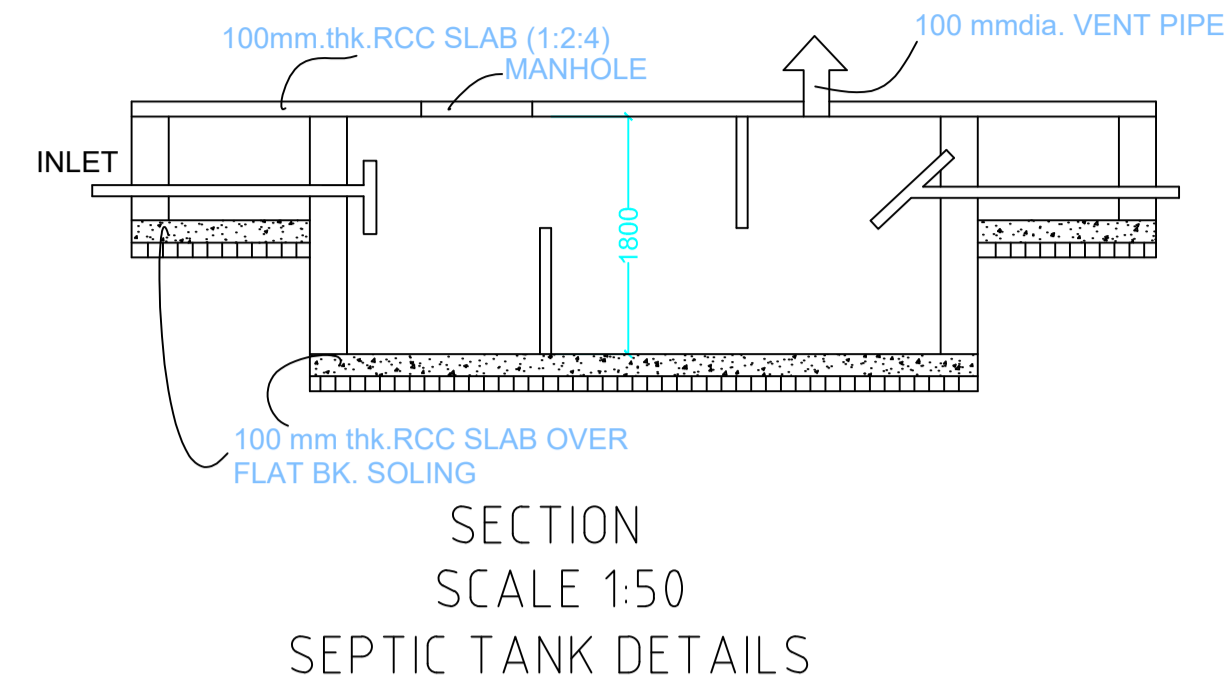
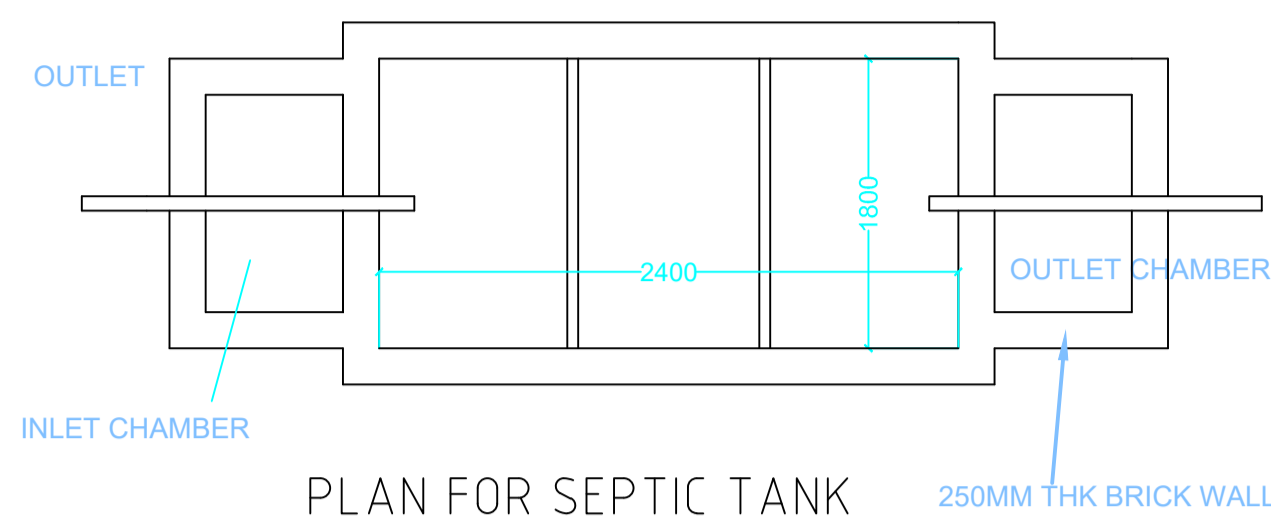

This is certify that the structure design is in accordance with the latest I-S code(I-S 875,I-S456-2002, I-S 1893-2000) for design  
 \* loading conditions (Seismic/wind/dead/live) and other all parameters are taken in account for safetyof the structure.

LTP NAME AND SIGNATURE	STRUCTURAL ENG'S NAME AND SIGNATURE	BUILDER NAME AND SIGNATURE	DIGITAL SIGNATURE
PRAWEEEN KUMAR MAHTO MNP/ENG/0005/2020			