

Proposal Basic Information	
Proposal File No.	MNP/BP/0024/W05/2023
Owner Name	URMILA DEVI
Khata No	1KA
Plot No	KA
Village Name	Madhupur Bazar
Use	Residential
SubUse	Bungalow/ Dwelling / Non Apartment

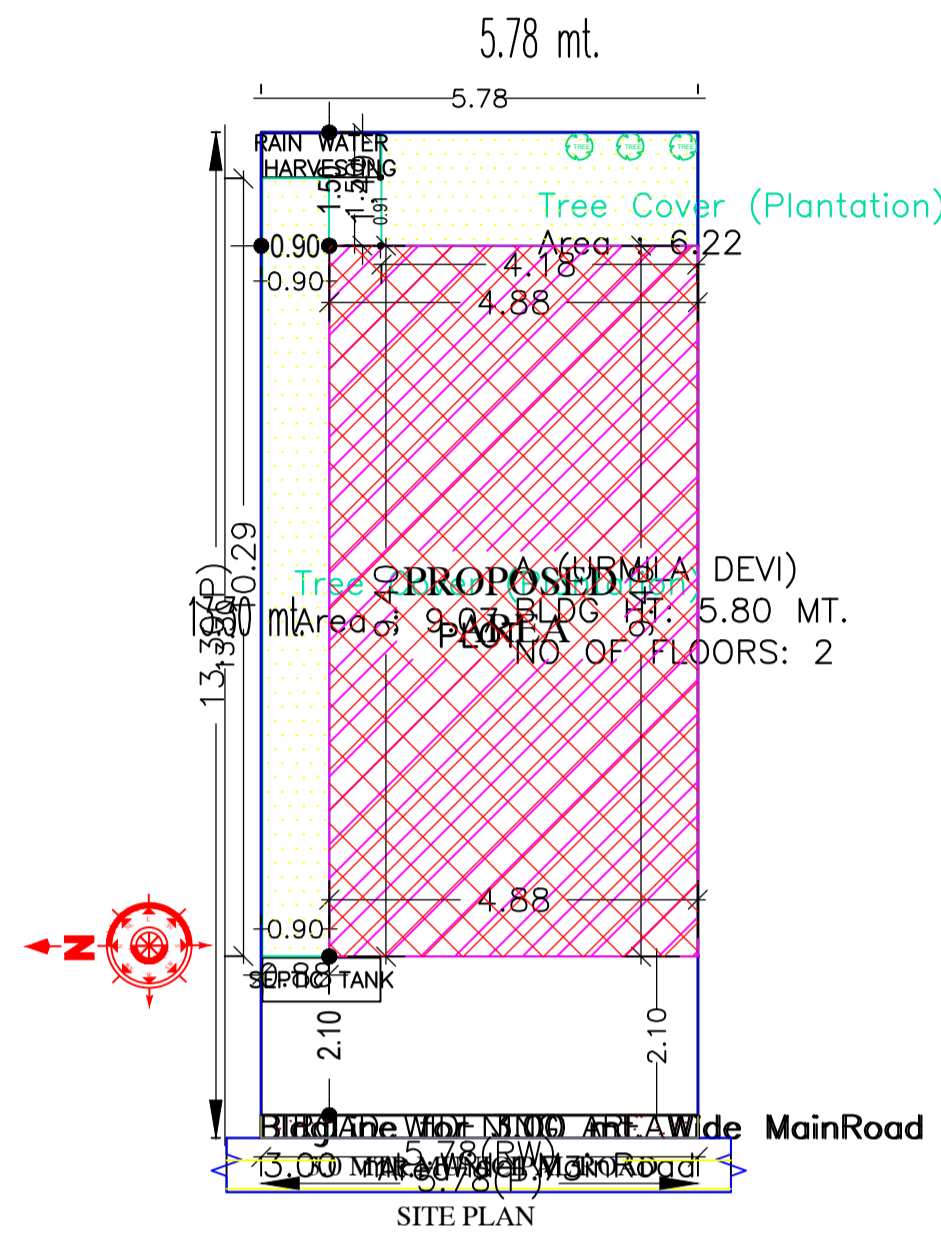

SITE PLAN

COLOR INDEX	
PLOT BOUNDARY	Black
ABUTTING ROAD	Green
PROPOSED CONSTRUCTION	Red
COMMON PLOT	Yellow
ROAD WIDENING AREA	Blue
EXISTING (To be retained)	Light Blue
EXISTING (To be demolished)	Light Yellow

Buildingwise Floor FAR Details

Floor Name	Building Name A (URMILA DEVI)				Total			
	Proposed Built Up Area (Sq.mt.)	Existing Built up Area (Sq.mt.)	Proposed FAR Area (Sq.mt.)	Existing FAR Area (Sq.mt.)	Total Proposed Built Up Area (Sq.mt.)	Total Existing Built up Area (Sq.mt.)	Total FAR Area (Sq.mt.)	Total Existing FAR Area (Sq.mt.)
Ground Floor	0.00	45.83	0.00	45.83	0.00	45.83	0.00	45.83
First Floor	45.83	0.00	44.10	0.00	45.83	0.00	44.10	0.00
Terrace Floor	0.00	0.00	0.00	0.00	0.00	0.00	0.00	0.00
<b>Total :</b>	<b>45.83</b>	<b>45.83</b>	<b>44.10</b>	<b>45.83</b>	<b>45.83</b>	<b>45.83</b>	<b>44.10</b>	<b>45.83</b>

FAR & Tenement Details (Table 4c-1)

Building	No. of Same Bldg	Total Built Up Area (Sq.mt.)	Existing Built Up Area (Sq.mt.)	Proposed Built Up Area (Sq.mt.)	Deductions (Area in Sq.mt.)	Existing FAR Area (Sq.mt.)	Proposed FAR Area (Sq.mt.)	Total FAR Area (Sq.mt.)	Total Consumed Additional FAR Area (Sq.mt.)	Tnmt (No.)
A (URMILA DEVI)	1	91.66	45.83	45.83	1.73	45.83	44.10	89.93	89.93	01
<b>Grand Total</b>	<b>1</b>	<b>91.66</b>	<b>45.83</b>	<b>45.83</b>	<b>1.73</b>	<b>45.83</b>	<b>44.10</b>	<b>89.93</b>	<b>89.93</b>	<b>01</b>

Building USE/SUBUSE Details

Building Name	Building Use	Building SubUse	Building Structure
A (URMILA DEVI)	Residential	Bungalow/ Dwelling / Non Apartment	Non-Highrise

AREA STATEMENT	VERSION NO.: 1.0.66
MADHUPUR NAGAR	VERSION DATE: 16/10/2020
PARISHAD	
PROJECT DETAIL:	
Region: JHARKHAND URBAN LOCAL BODIES	Plot Use: Residential
District: DEOGHAR	Plot SubUse: Bungalow/ Dwelling / Non Apartment
Authority: MADHUPUR NAGAR PARISHAD	PlotNearby/ReligiousStructure: NA
Inward_No: MNP/BP/0024/W05/2023	Plot/SubPlot No: KA
Application Type: General Proposal	North: Plot No. - VENDORS LAND
Project Type: Building Permission	South: Plot No. - LAND OF MALTI DEVI
Nature of Development: Addition or Alteration	East: Plot No. - VENDORS LAND
Location of Development Area: Old Area	West: Road Width - 3.0
AREA DETAILS:	
AREA OF PLOT (Minimum)	(A) 76.81
Deduction for NetPlot Area	
Road Widening Area	1.73
Total	1.73
NET AREA OF PLOT(Gross Plot Area - Deduction from Gross Plot area)	(A-Deductions) 75.08
Deduction for Balance Plot Area(from Gross Plot Area)	
Road Widening Area	1.73
Common Plot	15.28
Total	17.02
BALANCE AREA OF PLOT(Net Plot Area - Recreational/Amenity space)	(A-Deductions) 59.79
PLOT AREA FOR COVERAGE(Net Plot Area)	(A-Deductions) 75.08
Plot Area for FAR (Net Plot Area + RoadWidening Area)	(A-Deductions) 75.08
COVERAGE CHECK	
Permissible Coverage area ( 70.00 % )	52.56
Proposed Coverage Area ( 61.05 % )	45.83
Total Prop. Coverage Area ( 61.05 % )	45.83
Balance coverage area ( 8.96 % )	6.73
FAR CHECK	
Perm. FAR Area ( 1.200 )	90.10
Total Perm. FAR area	90.10
Residential FAR	89.92
Proposed FAR Area	89.92
Total Proposed FAR Area	89.92
Consumed FAR (Factor)	1.20
Balance FAR Area	0.18
BUILT UP AREA CHECK	
Total Proposed BuiltUp Area	91.66
ARCHITECT (Regd)	PRAWEEEN KUMAR MAHTO
ENGINEER (Regd)	
SUPERVISOR (Regd)	
OWNER (Regd)	URMILA DEVI
DEVELOPMENT AUTHORITY	LOCAL BODY

LTP NAME AND SIGNATURE	STRUCTURAL ENG'S NAME AND SIGNATURE	BUILDER NAME AND SIGNATURE	DIGITAL SIGNATURE
PRAWEEEN KUMAR MAHTO MNP/ENG/0005/2020			

Proposal Basic Information	
Proposal File No.	MNP/IBP/0024/W05/2023
Owner Name	URMILA DEVI
Khata No	1KA
Plot No	KA
Village Name	Madhupur Bazar
Use	Residential
SubUse	Bungalow/ Dwelling / Non Apartment

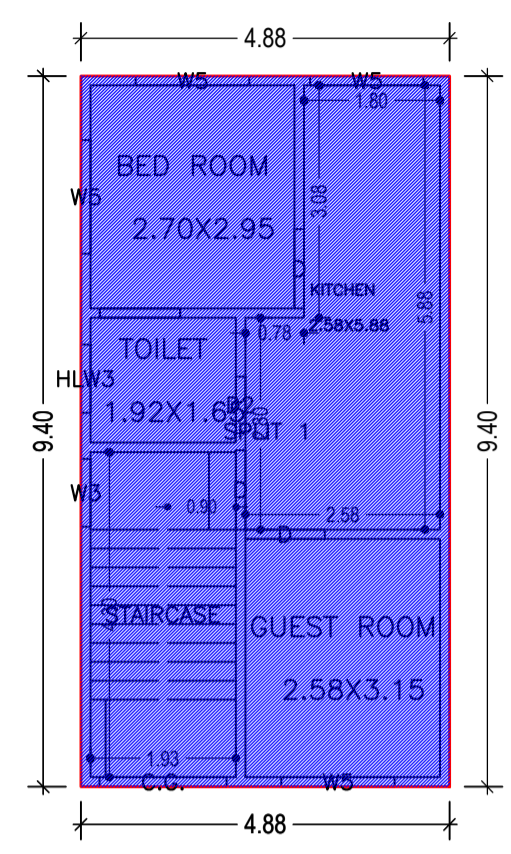

GROUND FLOOR PLAN (Existing) (SCALE 1:100)

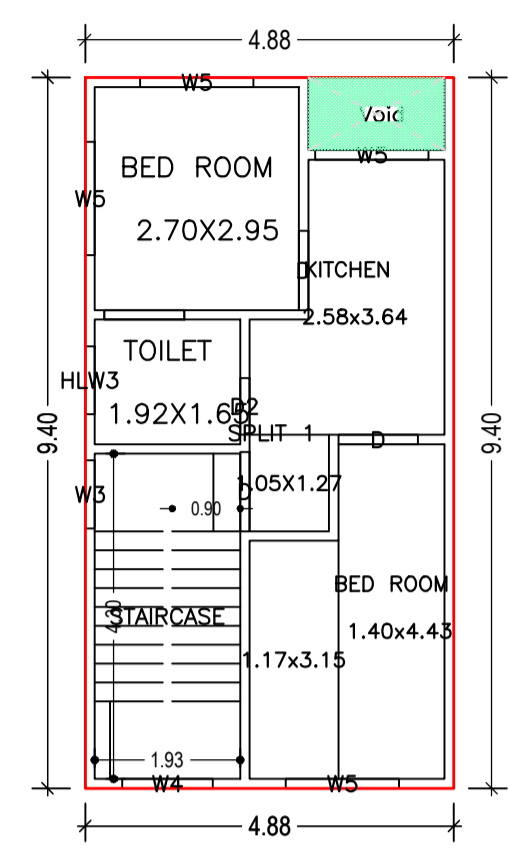

FIRST FLOOR PLAN (Proposed) (SCALE 1:100)

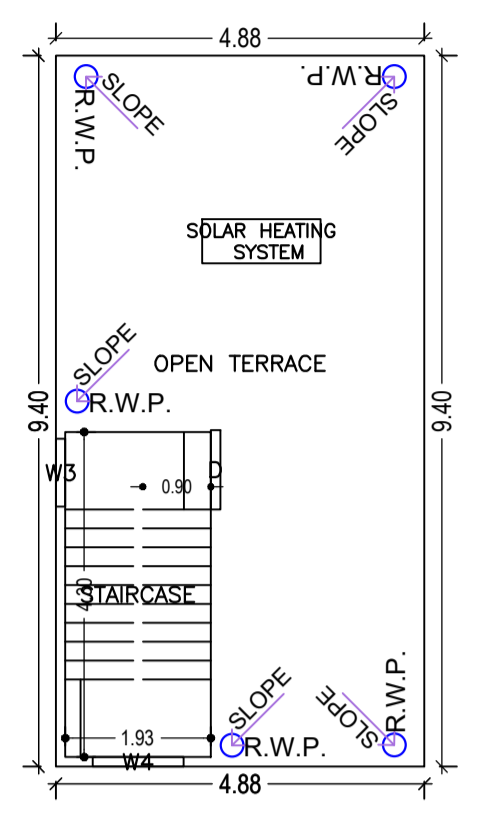

TERRACE FLOOR PLAN (SCALE 1:100)

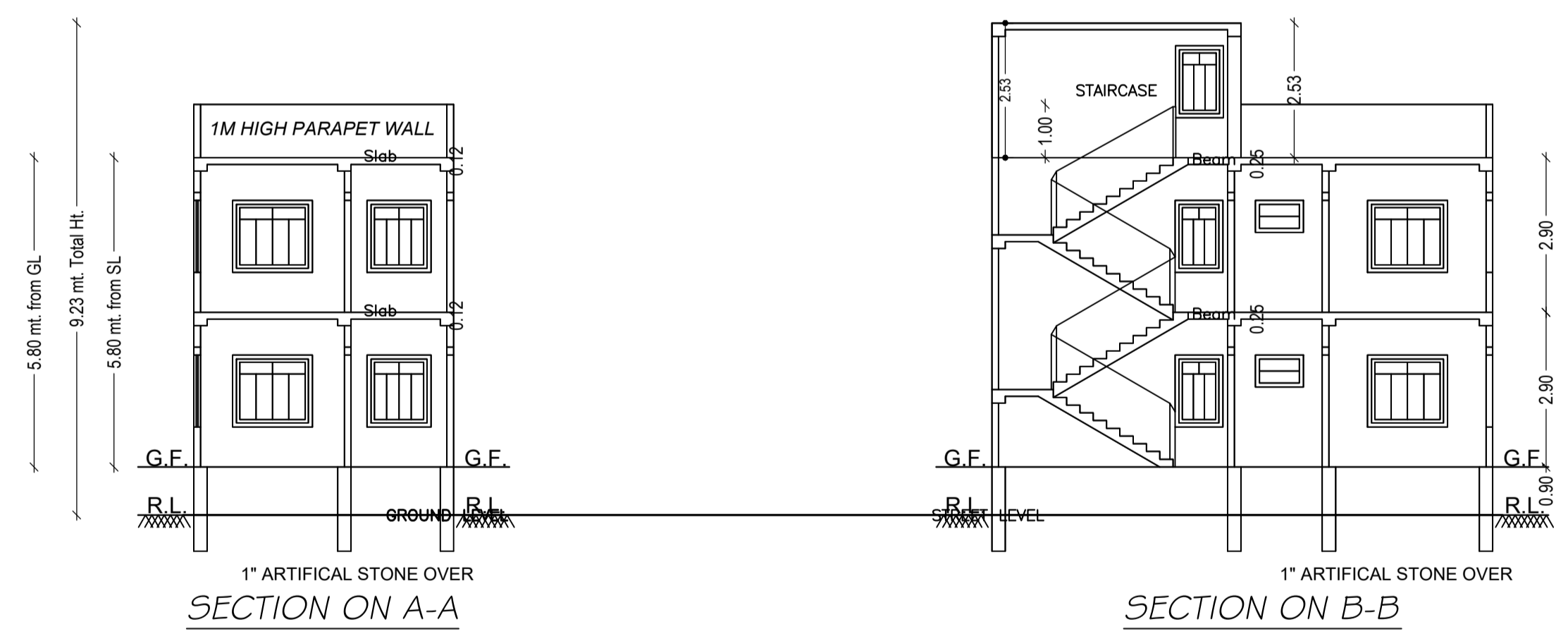

UnitBUA Table for Building :A (URMILA DEVI)

FLOOR	Name	UnitBUA Type	Entity Type	UnitBUA Area	Carpet Area	No. of Rooms	No. of Tenement
GROUND FLOOR PLAN	SPLIT 1	FLAT	Existing	71.42	71.15	4	1
FIRST FLOOR PLAN	SPLIT 1	FLAT	Proposed	0.00	0.00	4	0
Total:	-	-	-	71.42	71.15	8	1

SCHEDULE OF DOOR:

BUILDING NAME	NAME	LENGTH	HEIGHT	NOS
A (URMILA DEVI)	D2	0.75	2.10	02
A (URMILA DEVI)	D	1.05	2.10	06

SCHEDULE OF WINDOW/VENTILATION:

BUILDING NAME	NAME	LENGTH	HEIGHT	NOS
A (URMILA DEVI)	HLW3	0.90	0.60	02
A (URMILA DEVI)	W3	0.90	1.35	03
A (URMILA DEVI)	W4	1.20	1.35	02
A (URMILA DEVI)	W5	1.50	1.35	08

Building :A (URMILA DEVI)

Floor Name	Total Built Up Area (Sq.mt.)	Existing Built Up Area (Sq.mt.)	Proposed Built Up Area (Sq.mt.)	Deductions (Area in Sq.mt.)	Existing FAR Area (Sq.mt.)	Proposed FAR Area (Sq.mt.)	Total FAR Area (Sq.mt.)	Total Consumed Additional FAR Area (Sq.mt.)	Tnmt (No.)
Ground Floor	45.83	45.83	0.00	0.00	45.83	0.00	45.83	45.83	01
First Floor	45.83	0.00	45.83	1.73	0.00	44.10	44.10	44.10	00
Terrace Floor	0.00	0.00	0.00	0.00	0.00	0.00	0.00	0.00	00
Total :	91.66	45.83	45.83	1.73	45.83	44.10	89.93	89.93	01
Total Number of Same Buildings :	1								
Total :	91.66	45.83	45.83	1.73	45.83	44.10	89.93	89.93	01

LTP NAME AND SIGNATURE	STRUCTURAL ENG'S NAME AND SIGNATURE	BUILDER NAME AND SIGNATURE	DIGITAL SIGNATURE
PRAWEEEN KUMAR MAHTO MNP/ENG/0005/2020			

Proposal Basic Information	
Proposal File No.	MNP/BP/0024/W05/2023
Owner Name	URMILA DEVI
Khata No	1KA
Plot No	KA
Village Name	Madhupur Bazar
Use	Residential
SubUse	Bungalow/ Dwelling / Non Apartment

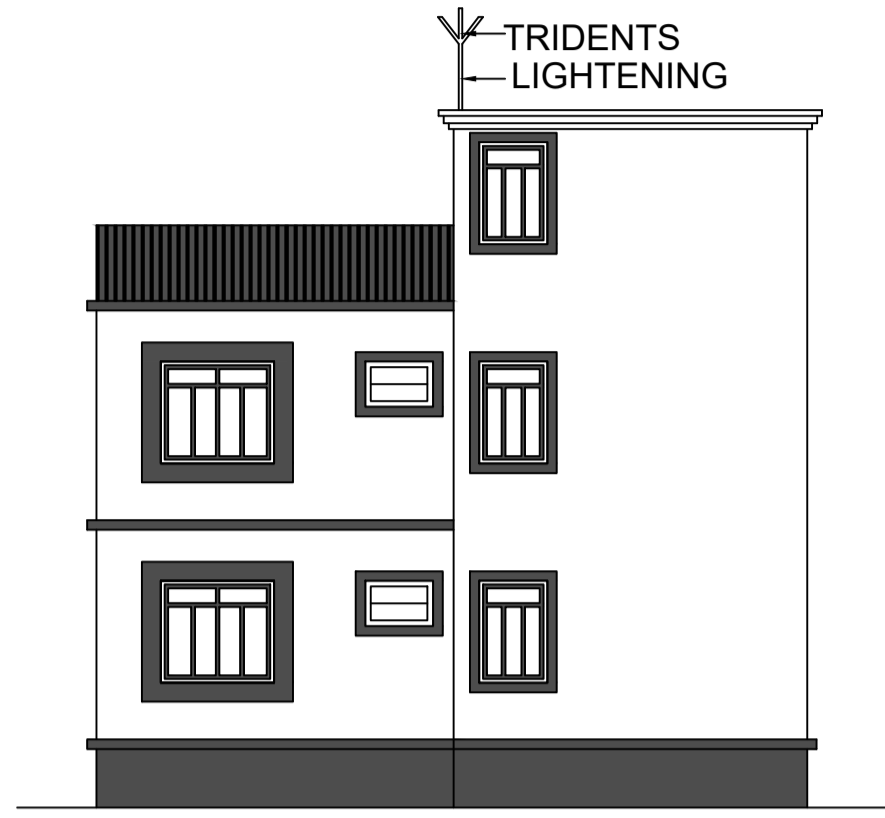

L.H.S. ELEVATION

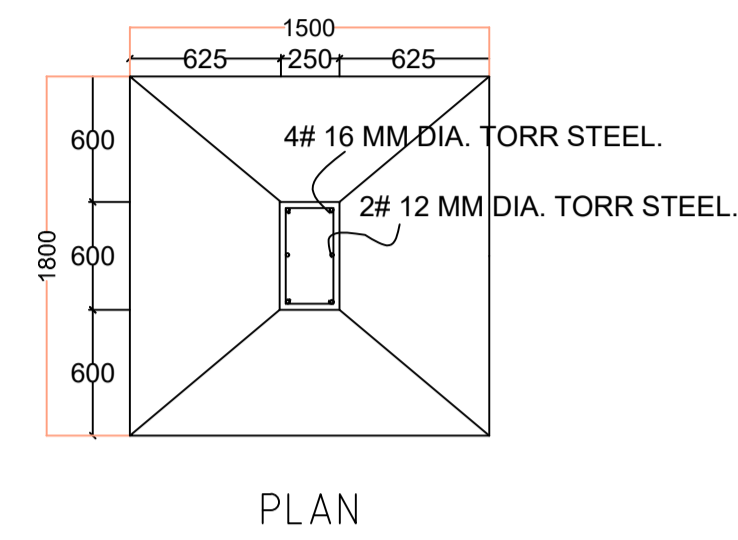

FOUNDATION DETAILS (ISOLATED R.C.C FOOTING)

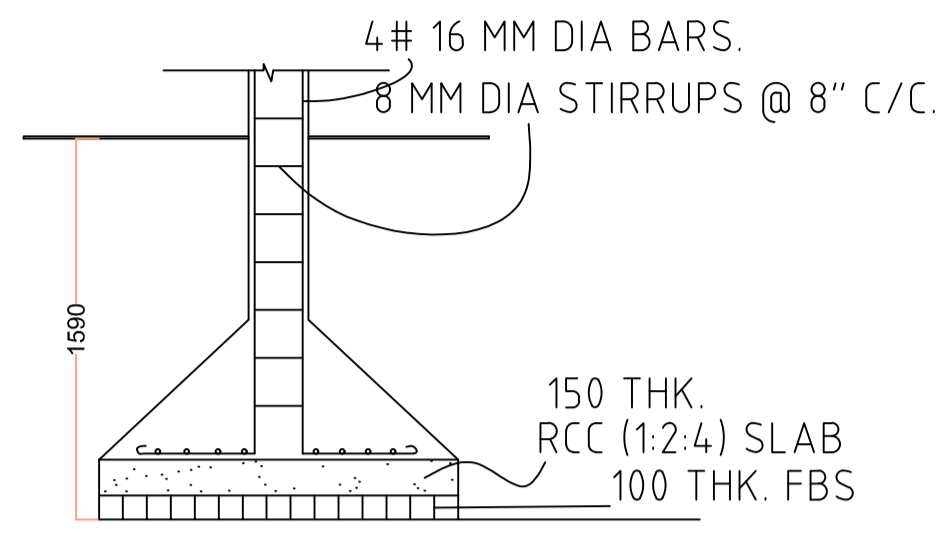

SECTION

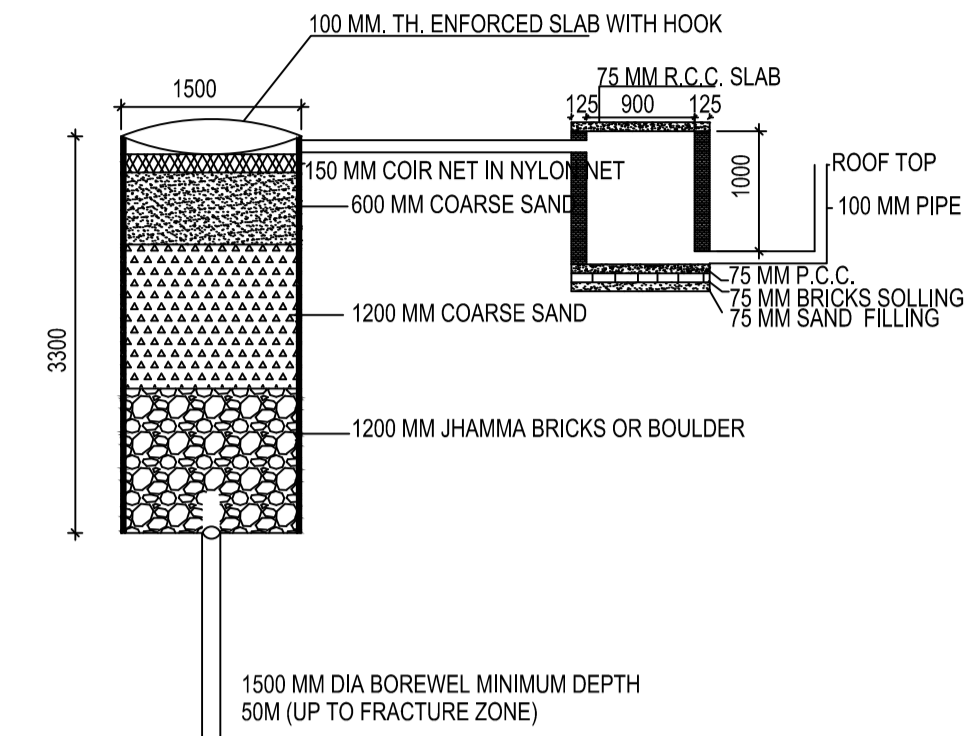

DETAIL OF GROUND WATER RECHARGING PIT WITH SILT TANK SCALE - N.T.S.

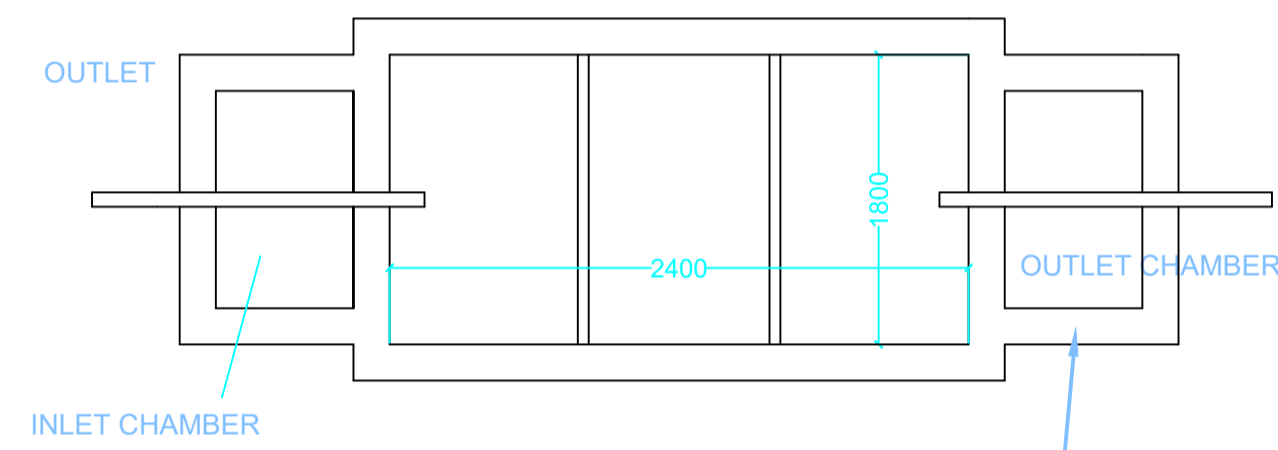

PLAN FOR SEPTIC TANK

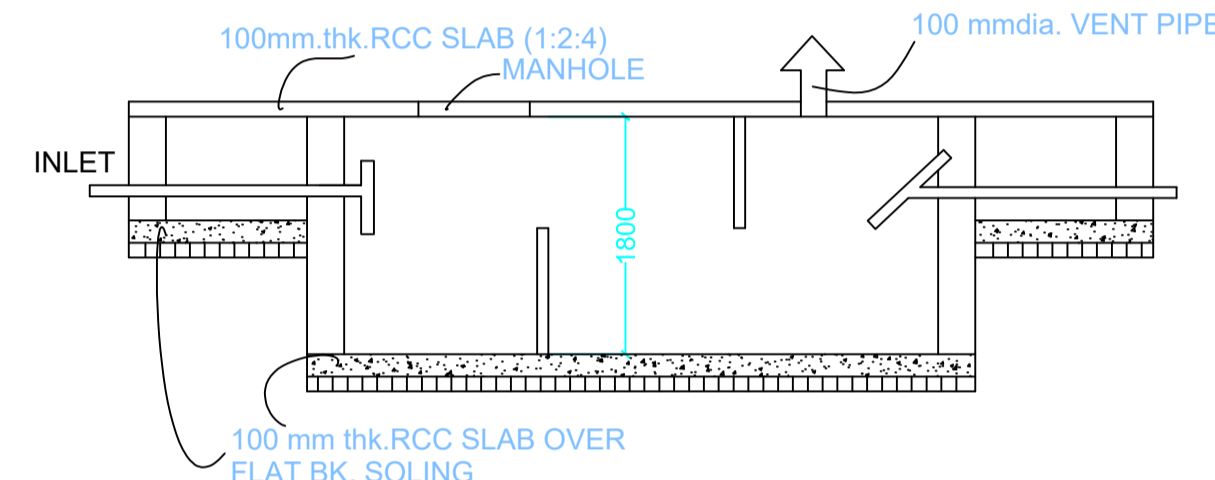

SECTION SCALE 1:50 SEPTIC TANK DETAILS

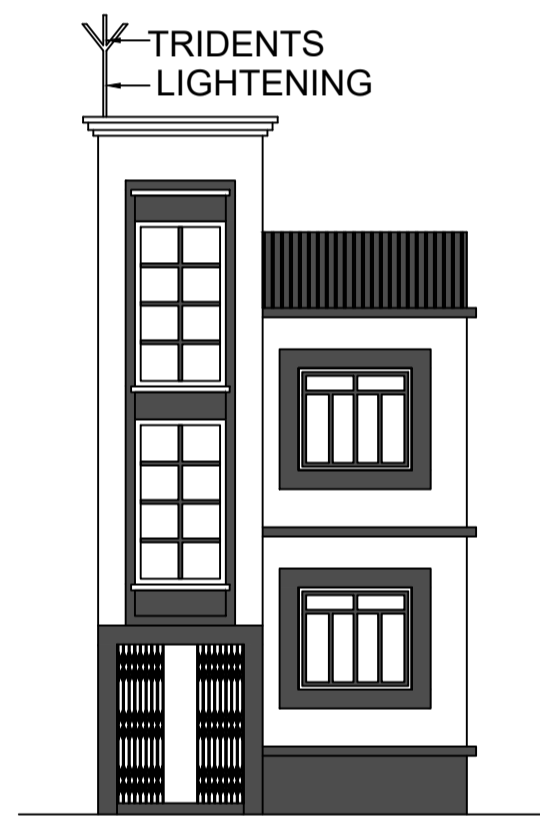

FRONT ELEVATION

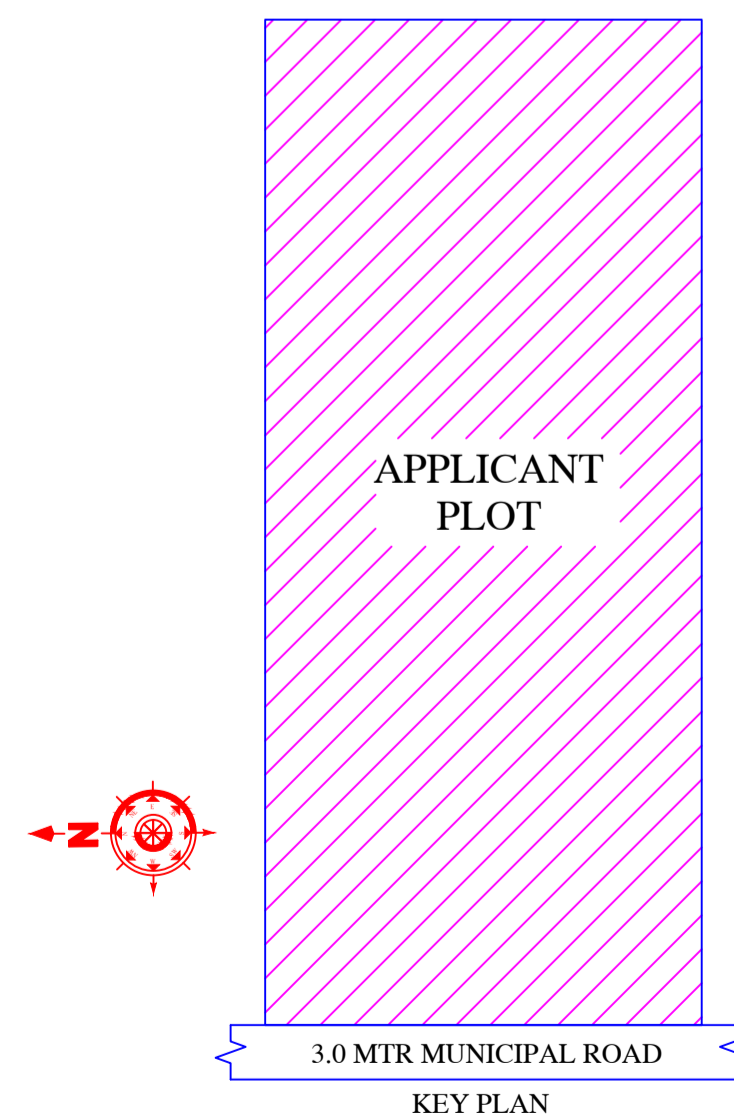

KEY PLAN

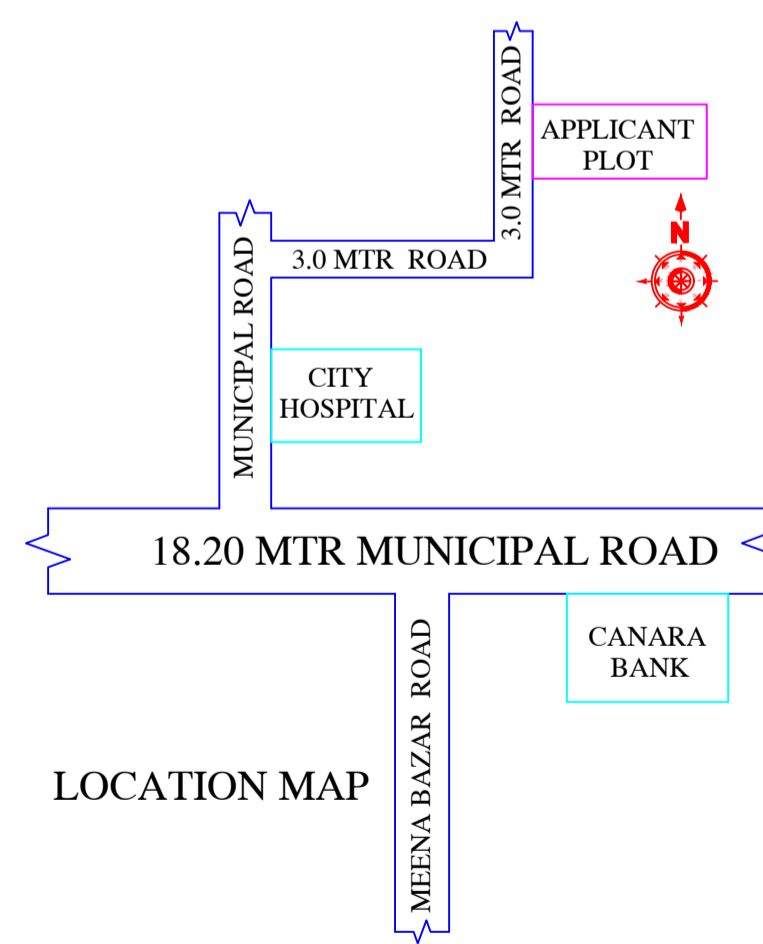

LOCATION MAP

This is certify that the structure design is in accordance with the latest I-S code(I-S 875,I-S456-2002, I-S 1893-2000) for design & loading conditions (Sessmic/wind/dead/live) and other all parameters are taken in account for safetyof the structure.

LTP NAME AND SIGNATURE	STRUCTURAL ENG'S NAME AND SIGNATURE	BUILDER NAME AND SIGNATURE	DIGITAL SIGNATURE
PRAWEEEN KUMAR MAHTO MNP/ENG/0005/2020			