

GROUND FLOOR PLAN (Proposed) (SCALE 1:100)

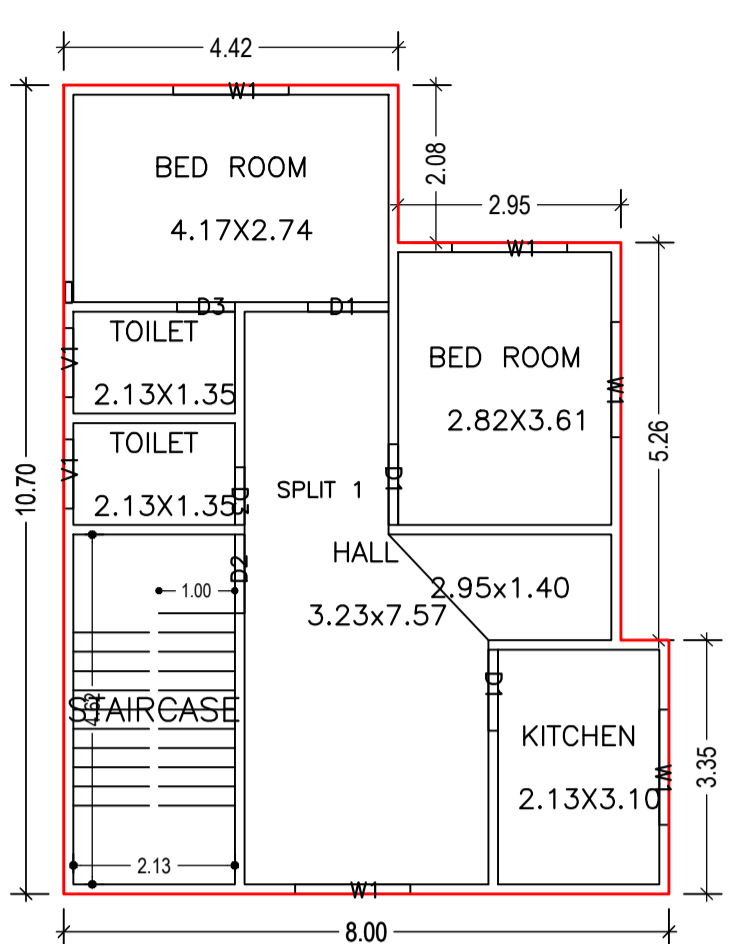

FIRST FLOOR PLAN (Proposed) (SCALE 1:100)

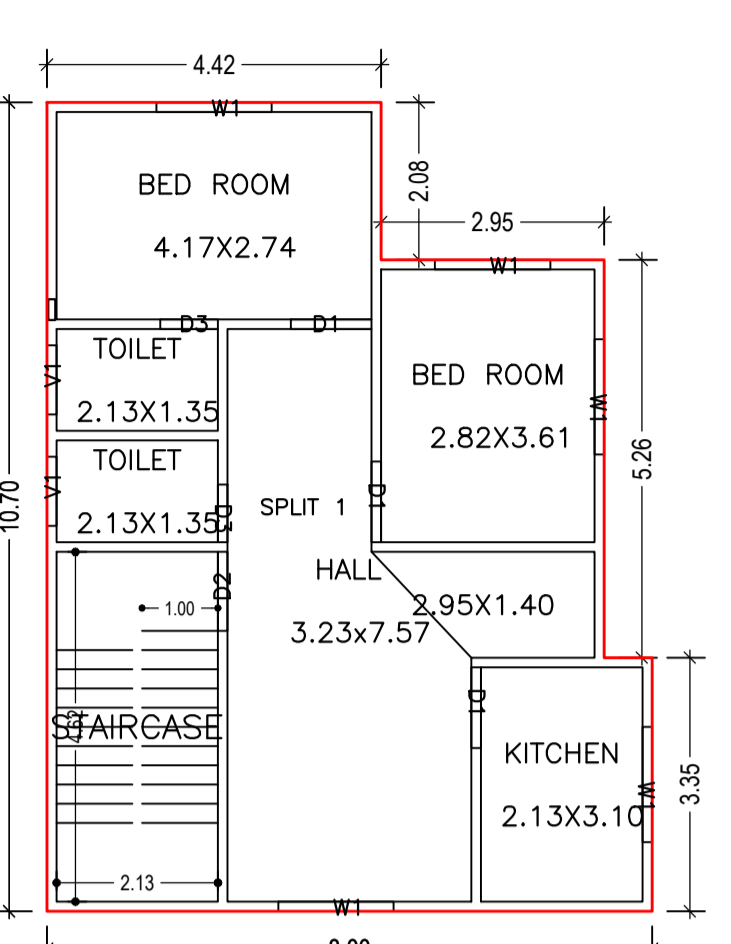

SECOND FLOOR PLAN (Proposed) (SCALE 1:100)

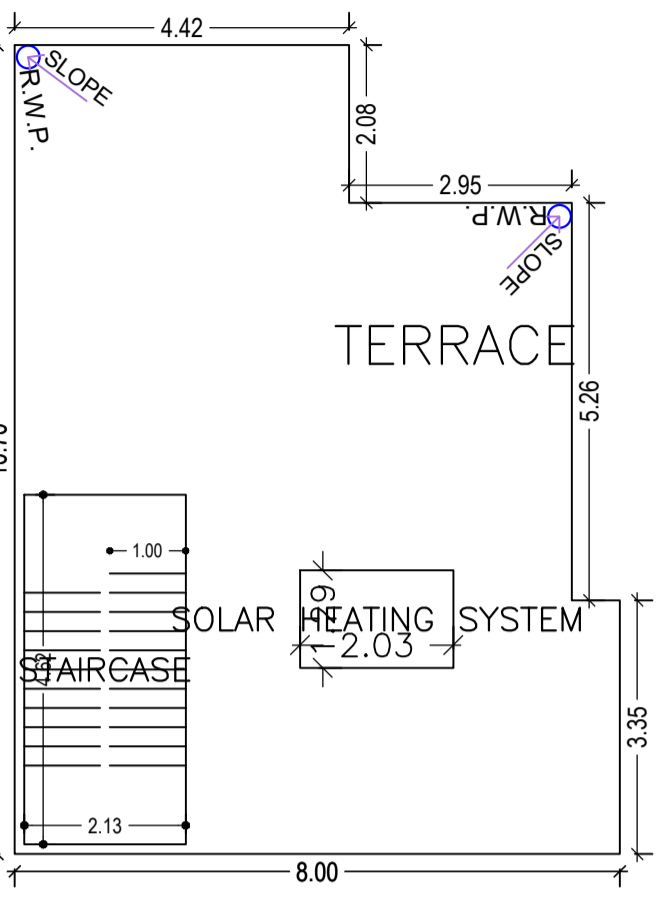

TERRACE FLOOR PLAN (SCALE 1:100)

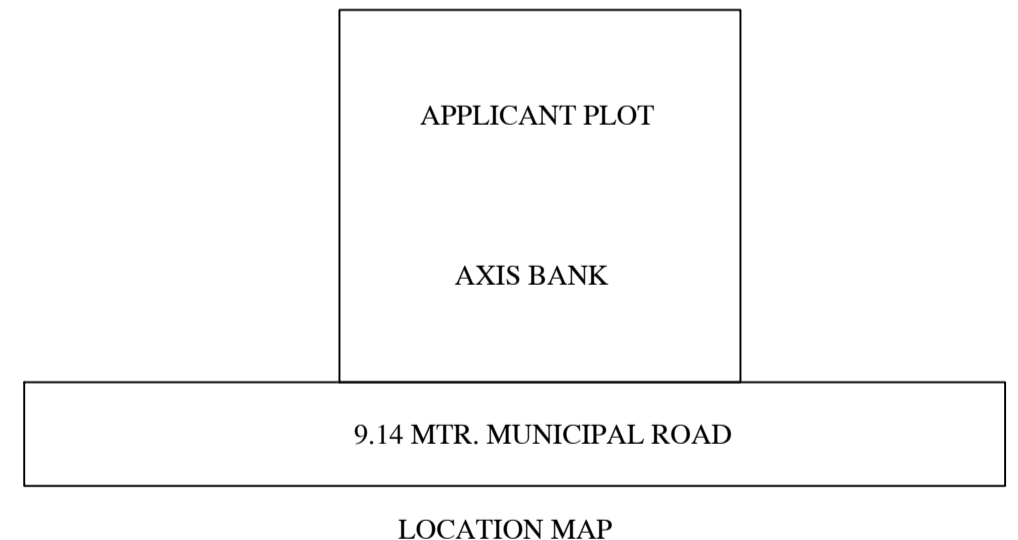
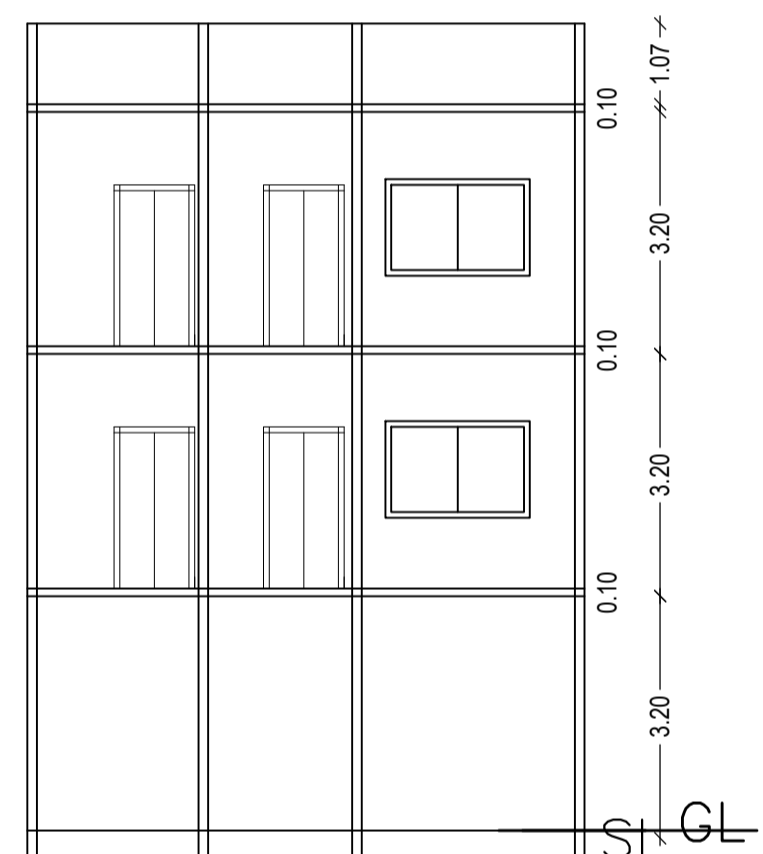
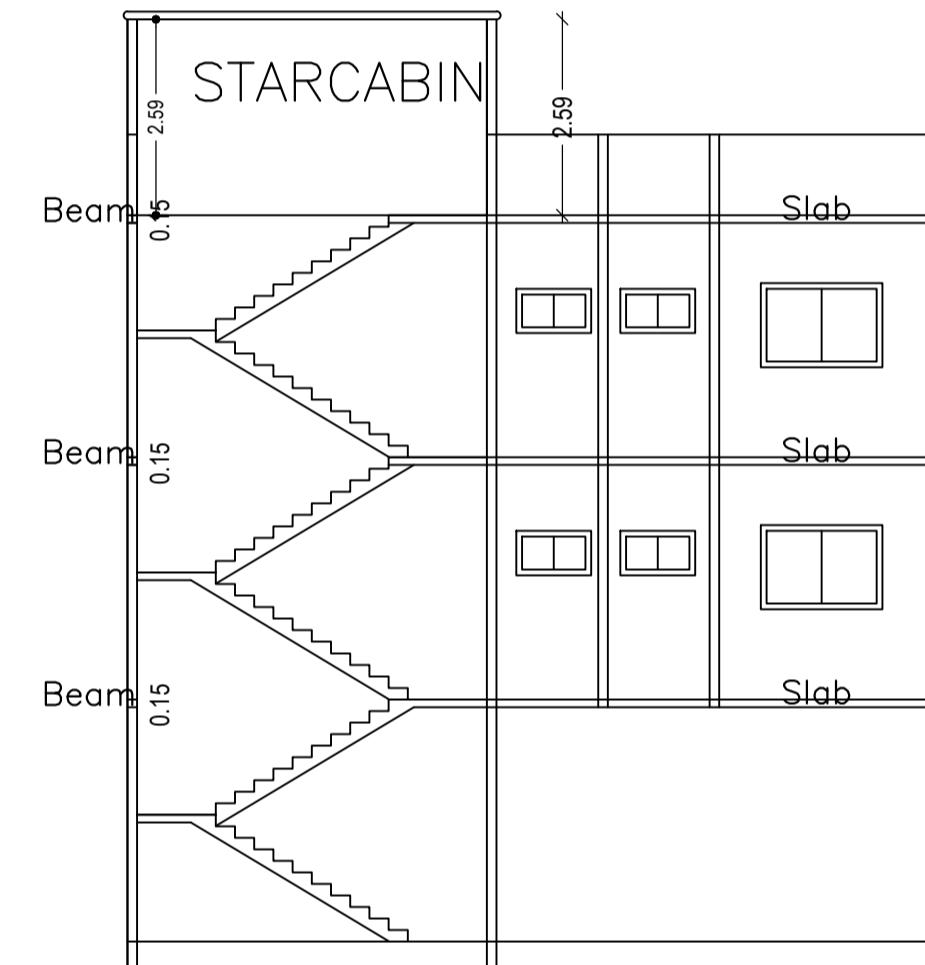
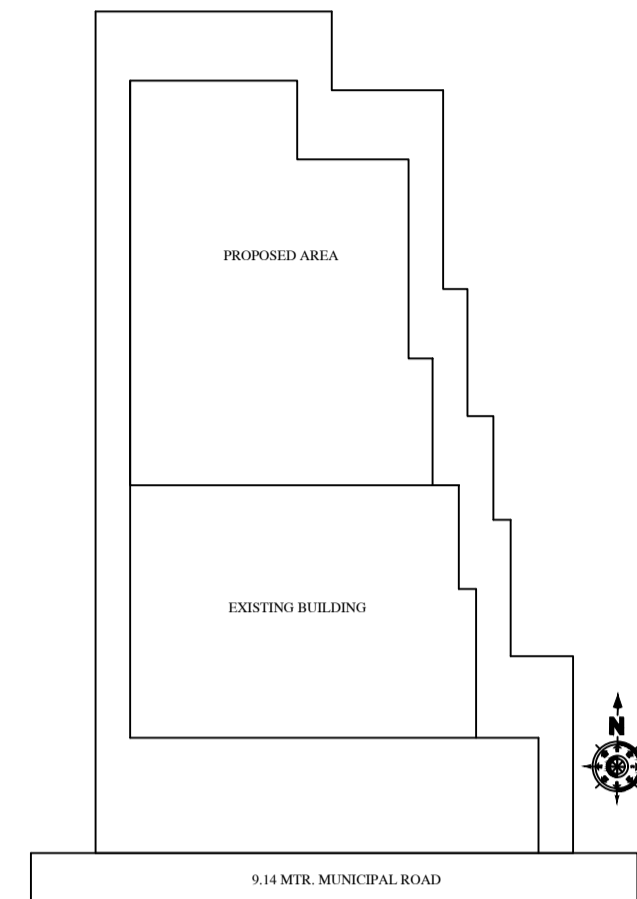

LOCATION MAP

Building :A (1)

Floor Name	Total Built Up Area (Sq.mt.)	Proposed FAR Area (Sq.mt.) Resi.	Total FAR Area (Sq.mt.)	Total Consumed Additional FAR Area (Sq.mt.)	Trmt (No.)
Ground Floor	74.83	74.83	74.83	74.83	01
First Floor	74.83	74.83	74.83	74.83	00
Second Floor	74.83	74.83	74.83	74.83	00
Terrace Floor	0.00	0.00	0.00	0.00	00
Total :	224.49	224.49	224.49	224.49	01
Total Number of Same Buildings	1				
Total :	224.49	224.49	224.49	224.49	01

SCHEDULE OF DOOR:

BUILDING NAME	NAME	LENGTH	HEIGHT	NOS
A (1)	D3	0.76	2.10	04
A (1)	D2	1.04	2.10	03
A (1)	D1	1.07	2.10	06
A (1)	D4	1.83	2.10	01

SCHEDULE OF WINDOW/VENTILATION:

BUILDING NAME	NAME	LENGTH	HEIGHT	NOS
A (1)	V1	0.91	0.45	04
A (1)	W1	1.52	1.20	15

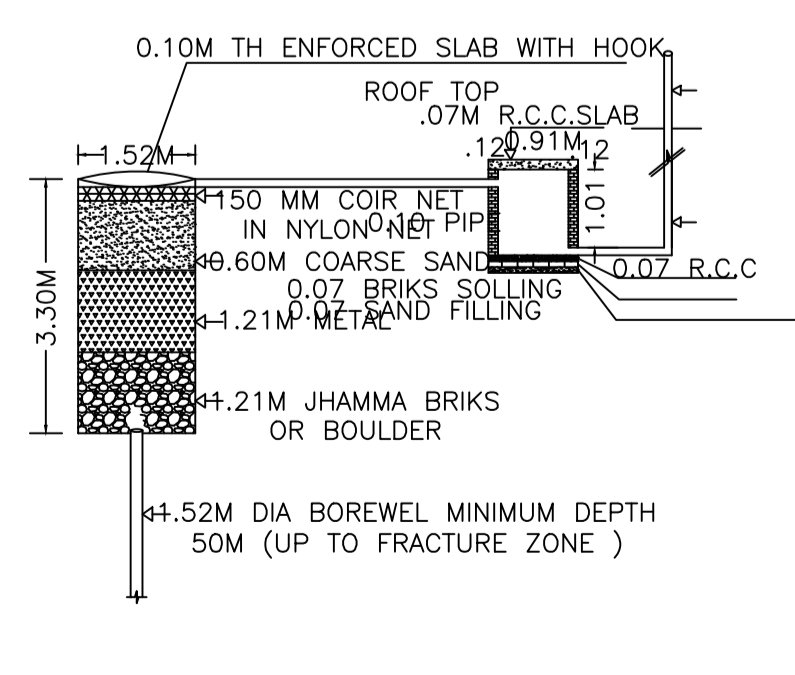

DETAIL OF GROUND WATER RECHARGING PIT WITH SILT TANK NOT TO SCALE

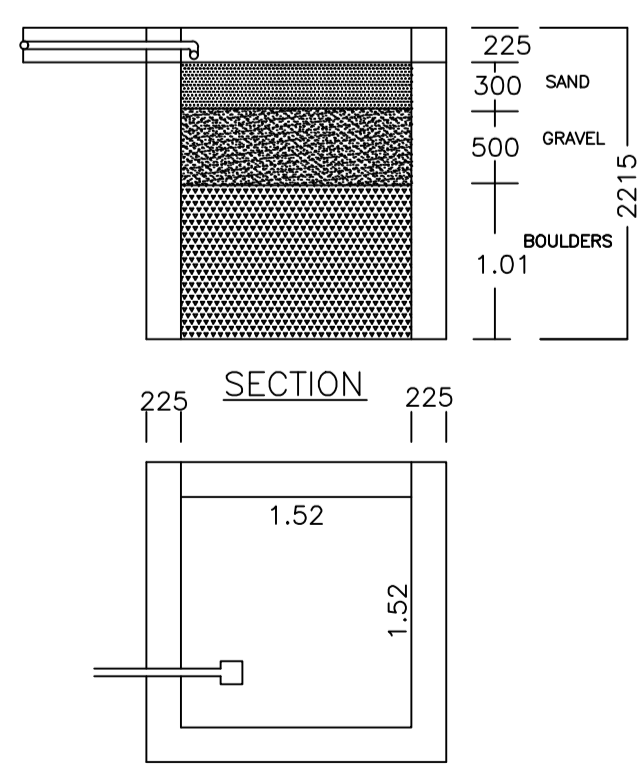

PLAN OF RAIN WATER HARVESTING (SCALE:-1:25)

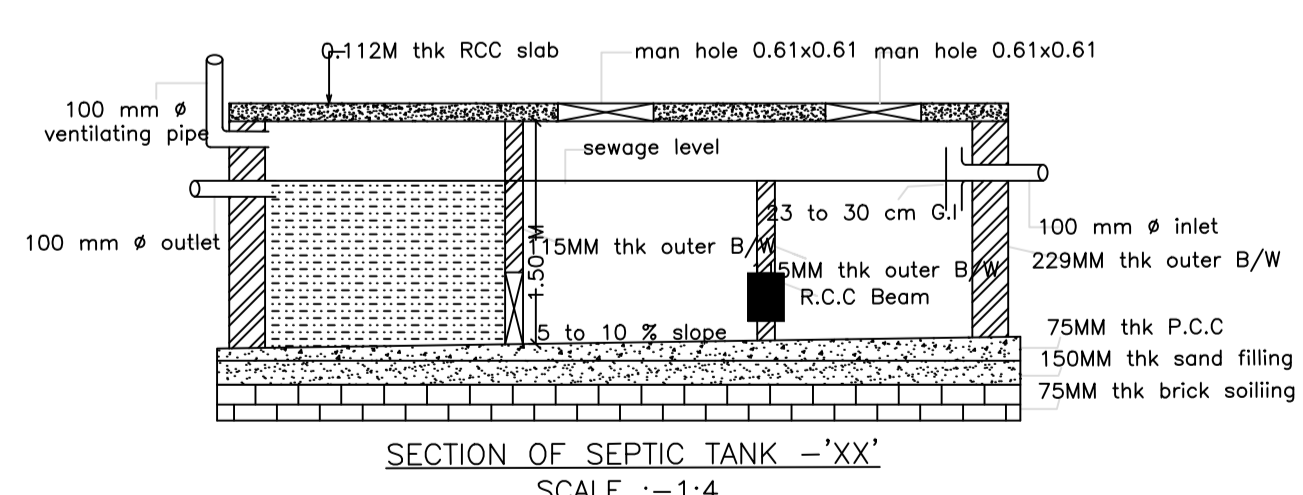

SECTION OF SEPTIC TANK 'XX' SCALE :-1:4

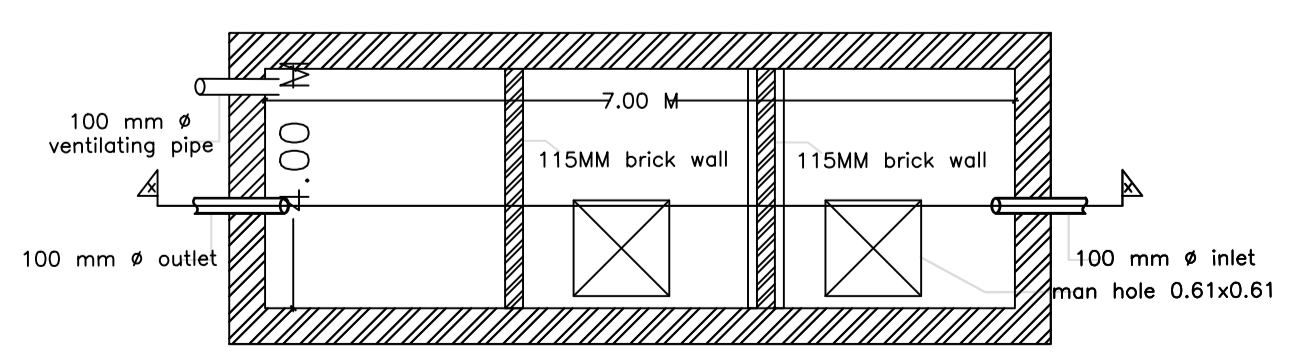

PLAN OF SEPTIC TANK

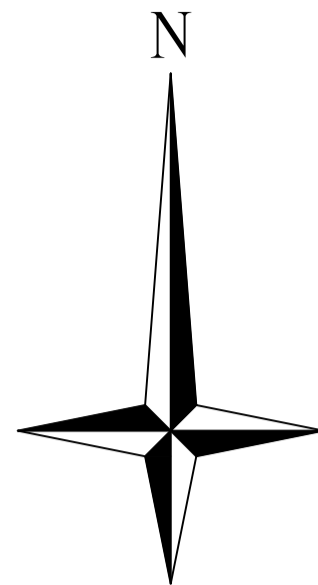

Proposal Basic Information

Proposal File No.	MNP/IB/0052/W07/2023
Owner Name	ANINDYA SEN
Khata No	34
Plot No	0/1
Village Name	Bara Shekhpura
Use	Residential
SubUse	Bungalow/ Dwelling / Non Apartment

AREA STATEMENT MADHUPUR NAGAR PARISHAD

AREA OF PLOT (Minimum)	(A)	SQ.MT.
NET AREA OF PLOT(Gross Plot Area - Deduction from Gross Plot area)	(A-Deductions)	228.67
Deduction for Balance Plot Area(from Gross Plot Area)		
Common Plot		21.92
Total		21.92
BALANCE AREA OF PLOT(Net Plot Area - Recreational/Amenity space)	(A-Deductions)	206.75
PLOT AREA FOR COVERAGE(Net Plot Area)	(A-Deductions)	228.67
Plot Area for FAR (Net Plot Area + RoadWidening Area)	(A-Deductions)	228.67
COVERAGE CHECK		
Permissible Coverage area (70.00 %)		160.07
Proposed Coverage Area (32.72 %)		74.83
Total Prop. Coverage Area (32.72 %)		74.83
Balance coverage area (37.28 %)		85.24
FAR CHECK		
Perm. FAR Area (2.000)		457.34
Total Perm. FAR area		457.34
Residential FAR		224.48
Proposed FAR Area		224.48
Total Proposed FAR Area		224.48
Consumed FAR (Factor)		0.98
Balance FAR Area		232.86
BUILT UP AREA CHECK		
Total Proposed BuiltUp Area		224.49
ARCHITECT (Regd) PRAWEEEN KUMAR MAHTO		
ENGINEER (Regd)		
SUPERVISOR (Regd)		
OWNER (Regd) ANINDYA SEN		
DEVELOPMENT AUTHORITY LOCAL BODY		

COLOR INDEX

PLOT BOUNDARY	Black
ABUTTING ROAD	Red
PROPOSED CONSTRUCTION	Green
COMMON PLOT	Yellow
ROAD WIDENING AREA	Blue
EXISTING (To be retained)	Orange
EXISTING (To be demolished)	Light Blue

Buildingwise Floor FAR Details

Floor Name	Building Name A (1)		Total	
	Proposed Built Up Area (Sq.mt.)	Proposed FAR Area (Sq.mt.)	Total Proposed Built Up Area (Sq.mt.)	Total FAR Area (Sq.mt.)
Ground Floor	74.83	74.83	74.83	74.83
First Floor	74.83	74.83	74.83	74.83
Second Floor	74.83	74.83	74.83	74.83
Terrace Floor	0.00	0.00	0.00	0.00
Total :	224.49	224.49	224.49	224.49

Building USE/SUBUSE Details

Building Name	Building Use	Building SubUse	Building Structure
A (1)	Residential	Bungalow/ Dwelling / Non Apartment	Non-Highrise

FAR & Tenement Details (Table 4c-1)

Building	No. of Same Bldg	Total Built Up Area (Sq.mt.)	Proposed FAR Area (Sq.mt.) Resi.	Total FAR Area (Sq.mt.)	Total Consumed Additional FAR Area (Sq.mt.)	Trmt (No.)
A (1)	1	224.49	224.49	224.49	224.49	01
Grand Total :	1	224.49	224.49	224.49	224.49	01

UnitBUA Table for Building :A (1)

FLOOR	Name	UnitBUA Type	UnitBUA Area	Carpet Area	No. of Rooms	No. of Tenement
GROUND FLOOR PLAN	SPLIT 1	FLAT	224.48	224.40	1	1
FIRST FLOOR PLAN	SPLIT 1	FLAT	0.00	0.00	6	0
SECOND FLOOR PLAN	SPLIT 1	FLAT	0.00	0.00	6	0
Total:	-	-	224.48	224.40	13	1

LTP NAME AND SIGNATURE PRAWEEEN KUMAR MAHTO MNP/ENG/0005/2020	STRUCTURAL ENG'S NAME AND SIGNATURE	BUILDER NAME AND SIGNATURE	DIGITAL SIGNATURE
---	-------------------------------------	----------------------------	-------------------