

Proposal Basic Information	
Proposal File No.	MNP/BI/0057/W22/2023
Owner Name	SHANTI DEVI
Khata No	59/43
Plot No	800
Village Name	Patharchptti
Use	Residential
SubUse	Bungalow/ Dwelling / Non Apartment

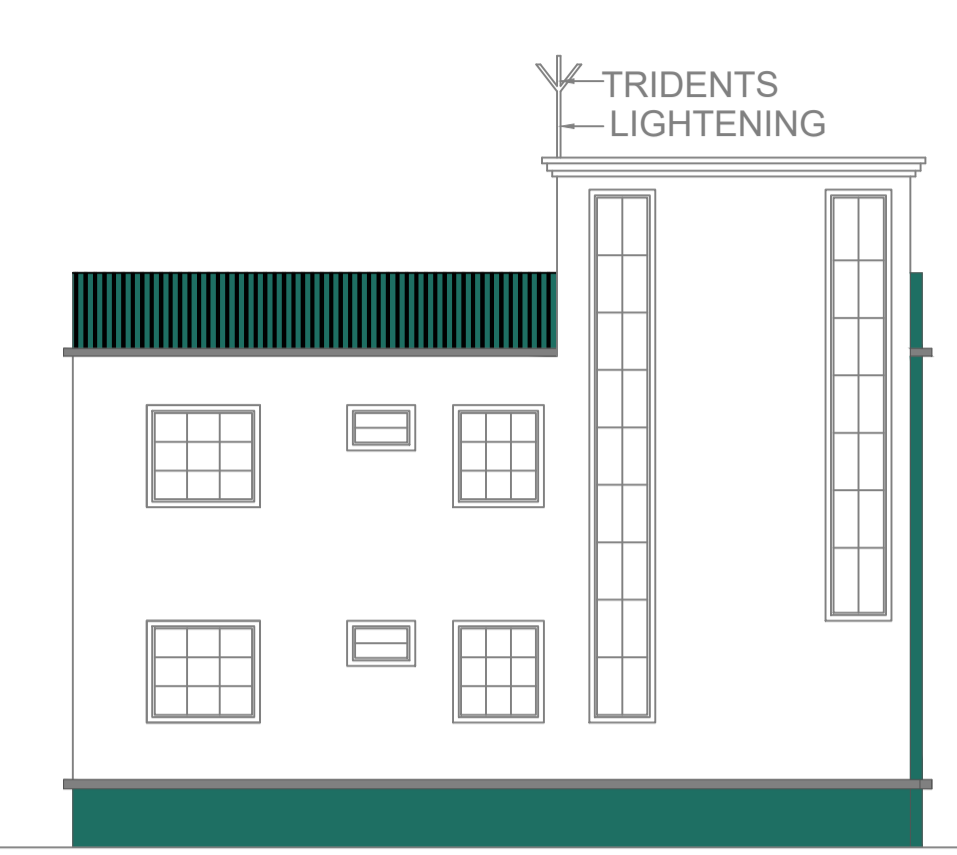
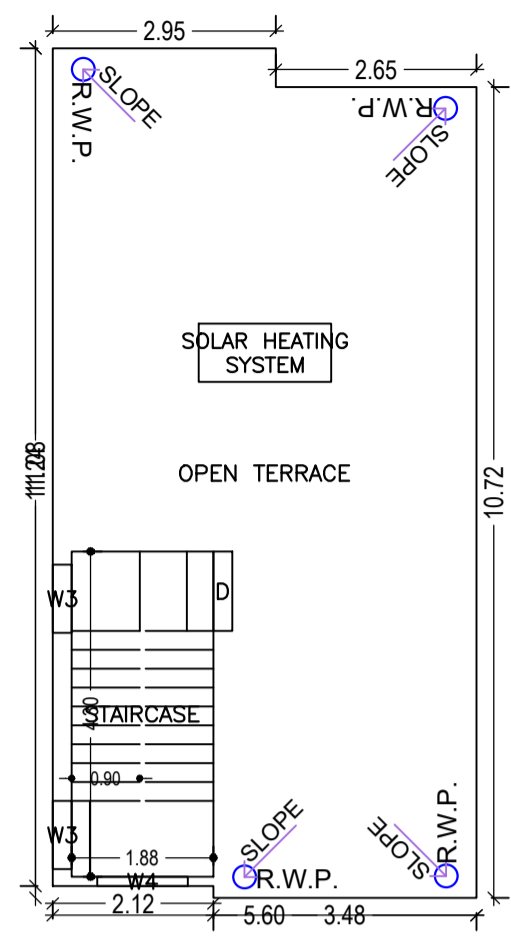
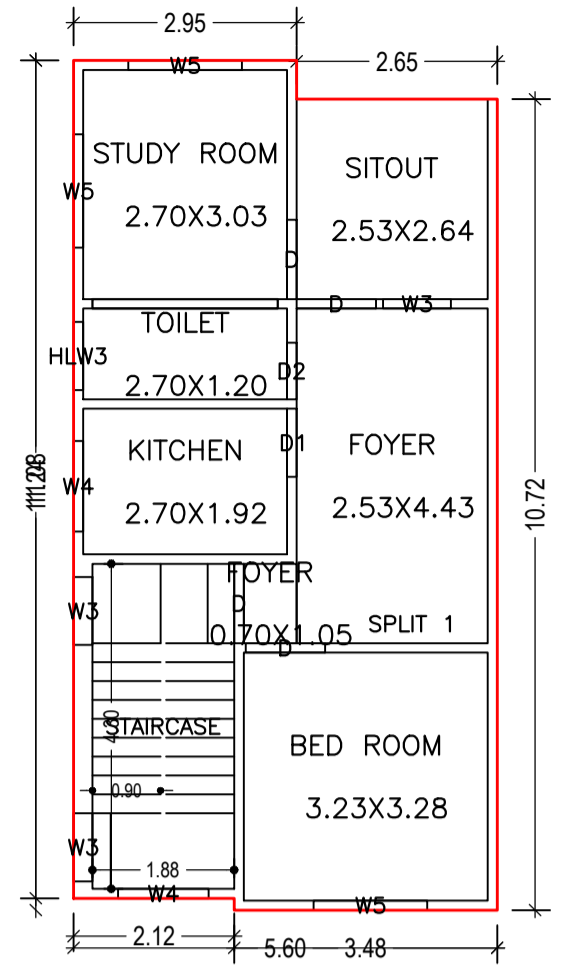
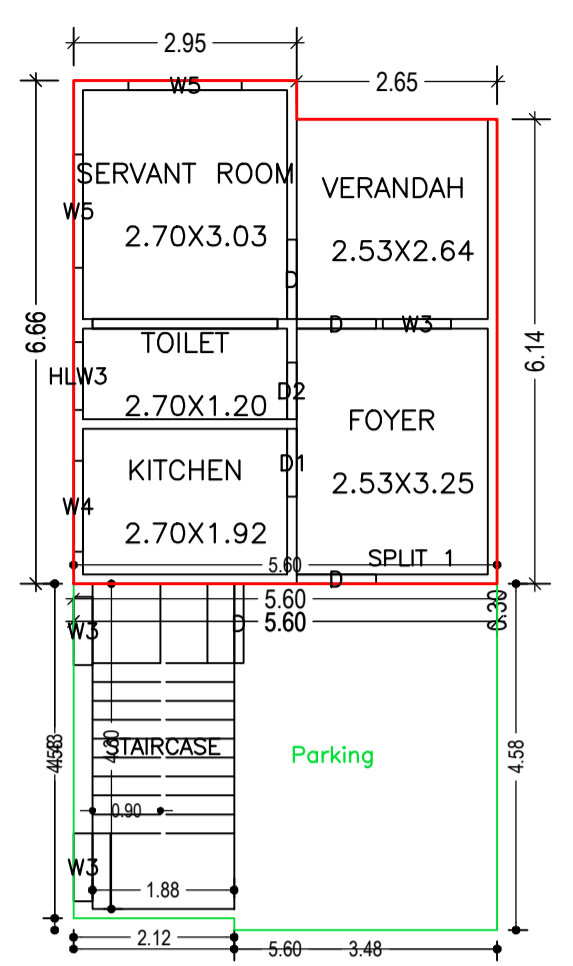
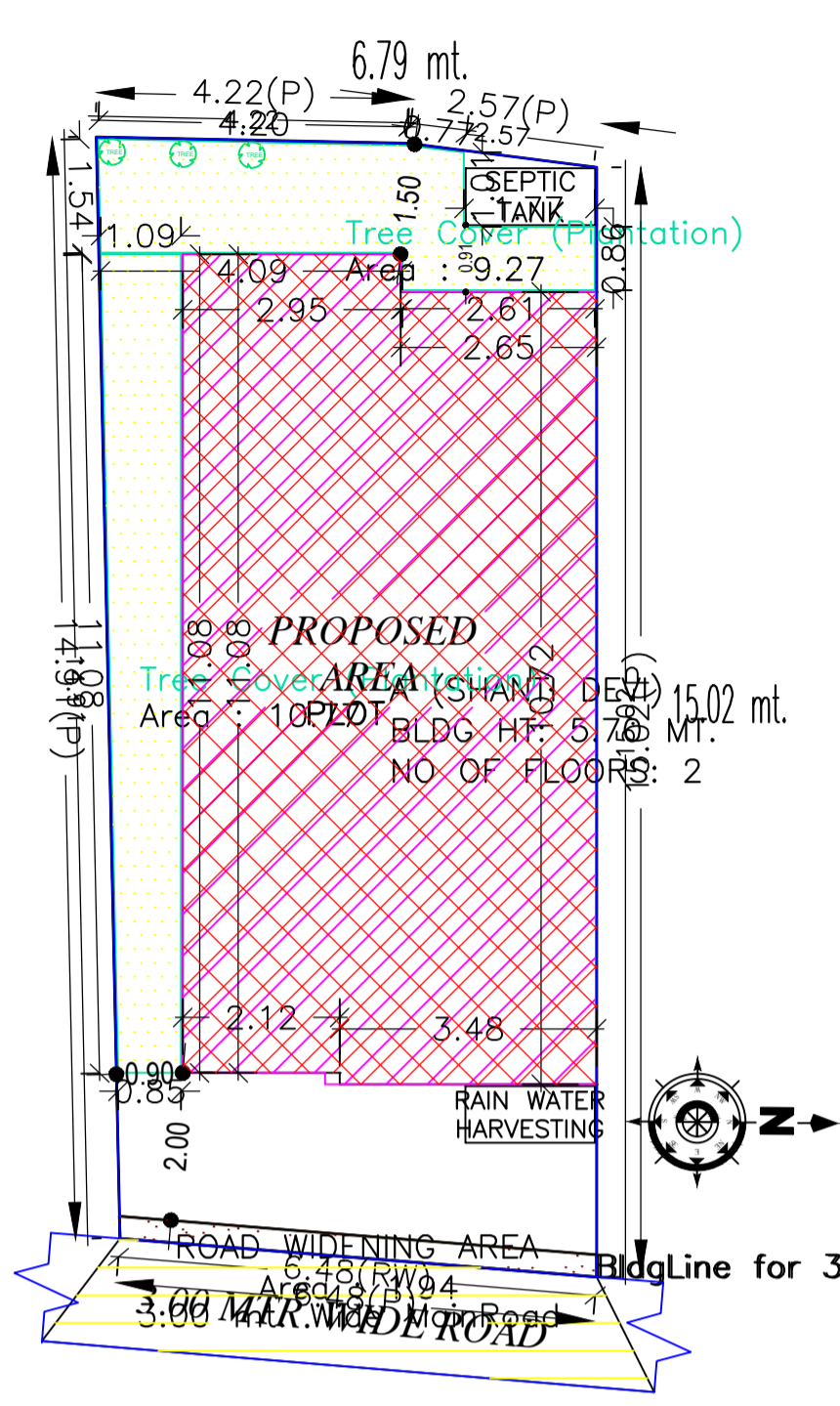
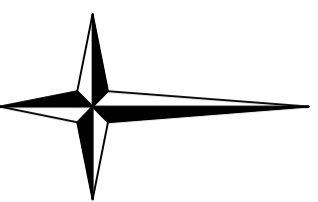

AREA STATEMENT		VERSION NO. : 1.0.66
MADHUPUR NAGAR PARISHAD		VERSION DATE: 16/10/2020
PROJECT DETAIL:		
Region: JHARKHAND URBAN LOCAL BODIES	Plot Use: Residential	
District: DEOGHAR	Plot SubUse: Bungalow/ Dwelling / Non Apartment	
Authority: MADHUPUR NAGAR PARISHAD	PlotNearby/ReligiousStructure: NA	
Inward No: MNP/BI/0057/W22/2023	PlotSubPlot No: 800	
Application Type: General Proposal	North: Plot No. - VENDORS LAND	
Project Type: Building Permission	South: Plot No. - SUB PLOT NO.-4	
Nature of Development: New	East: Road Width - 3.0	
Location of Development Area: Old Area	West: Plot No. - LAND OF ANSUIA DEVI GUTGUTIA AND OTHERS	

AREA DETAILS:		SQ.MT.
AREA OF PLOT (Minimum)	(A)	99.49
Deduction for NetPlot Area		
Road Widening Area		1.94
Total		1.94
NET AREA OF PLOT(Gross Plot Area - Deduction from Gross Plot area)	(A-Deductions)	97.55
Deduction for Balance Plot Area(from Gross Plot Area)		
Road Widening Area		1.94
Common Plot		20.04
Total		21.98
BALANCE AREA OF PLOT(Net Plot Area - Recreational/Amenity space)	(A-Deductions)	77.51
PLOT AREA FOR COVERAGE(Net Plot Area)	(A-Deductions)	97.55
Plot Area for FAR (Net Plot Area + RoadWidening Area)	(A-Deductions)	97.55

COVERAGE CHECK		
Permissible Coverage area (70.00 %)		68.29
Proposed Coverage Area (62.81 %)		61.27
Total Prop. Coverage Area (62.81 %)		61.27
Balance coverage area (7.20 %)		7.02

FAR CHECK		
Perm. FAR Area (1.200)		117.06
Total Perm. FAR area		117.06
Residential FAR		97.21
Proposed FAR Area		105.27
Total Proposed FAR Area		105.27
Consumed FAR (Factor)		1.08
Balance FAR Area		11.79

BUILT UP AREA CHECK		
Total Proposed BuiltUp Area		122.54
ARCHITECT (Regd)	RAKISHOR KUMAR	
ENGINEER (Regd)		
SUPERVISOR (Regd)		
OWNER (Regd)	SHANTI DEVI	
DEVELOPMENT AUTHORITY		LOCAL BODY

COLOR INDEX		
PLOT BOUNDARY		Black
ABUTTING ROAD		Red
PROPOSED CONSTRUCTION		Green
COMMON PLOT		Yellow
ROAD WIDENING AREA		Blue
EXISTING (To be retained)		Light Blue
EXISTING (To be demolished)		White

Buildingwise Floor FAR Details		Total	
Floor Name	Proposed Built Up Area (Sq.mt.)	Proposed FAR Area (Sq.mt.)	Total FAR Area (Sq.mt.)
Ground Floor	61.27	44.00	61.27
First Floor	61.27	61.27	61.27
Terrace Floor	0.00	0.00	0.00
Total:	122.54	105.27	122.54

Building USE/SUBUSE Details		Building Structure	
Building Name	Building Use	Building SubUse	Building Structure
A (SHANTI DEVI)	Residential	Bungalow/ Dwelling / Non Apartment	Non-Highrise

FAR & Tenement Details (Table 4c-1)		Total	
Building	No. of Same Bldg	Total Built Up Area (Sq.mt.)	Total Consumed Additional FAR Area (Sq.mt.)
A (SHANTI DEVI)	1	122.54	105.27
Grand Total :	1	122.54	105.27

This is certify that the structure design is in accordance with the latest I-S code(I-S 875,I-S456-2002, I-S 1893-2000) for design & loading conditions (Sessmic/wind/dead/live) and other all parameters are taken in account for safetyof the structure.

Building :A (SHANTI DEVI)						
Floor Name	Total Built Up Area (Sq.mt.)	Deductions (Area in Sq.mt.)	Proposed FAR Area (Sq.mt.)	Add Area In FAR (Sq.mt.)	Total FAR Area (Sq.mt.)	Total Consumed Additional FAR Area (Sq.mt.)
Ground Floor	61.27	17.27	35.94	8.06	44.00	44.00
First Floor	61.27	0.00	61.27	0.00	61.27	61.27
Terrace Floor	0.00	0.00	0.00	0.00	0.00	0.00
Total	122.54	17.27	97.21	8.06	105.27	105.27
Total Number of Same Buildings	1					
Total :	122.54	17.27	97.21	8.06	105.27	105.27

SCHEDULE OF DOOR:				
BUILDING NAME	NAME	LENGTH	HEIGHT	NOS
A (SHANTI DEVI)	D2	0.75	2.10	02
A (SHANTI DEVI)	D1	0.90	2.10	02
A (SHANTI DEVI)	D	1.05	2.10	07

SCHEDULE OF WINDOW/VENTILATION:				
BUILDING NAME	NAME	LENGTH	HEIGHT	NOS
A (SHANTI DEVI)	HLW3	0.90	0.60	02
A (SHANTI DEVI)	W3	0.90	1.35	06
A (SHANTI DEVI)	W3	0.90	2.10	02
A (SHANTI DEVI)	W4	1.20	1.35	04
A (SHANTI DEVI)	W5	1.50	1.35	05

UnitBUA Table for Building :A (SHANTI DEVI)						
FLOOR	Name	UnitBUA Type	UnitBUA Area	Carpet Area	No. of Rooms	No. of Tenement
GROUND FLOOR PLAN	SPLIT 1	FLAT	87.81	87.19	5	1
FIRST FLOOR PLAN	SPLIT 1	FLAT	0.00	0.00	7	0
Total:	-	-	87.81	87.19	12	1

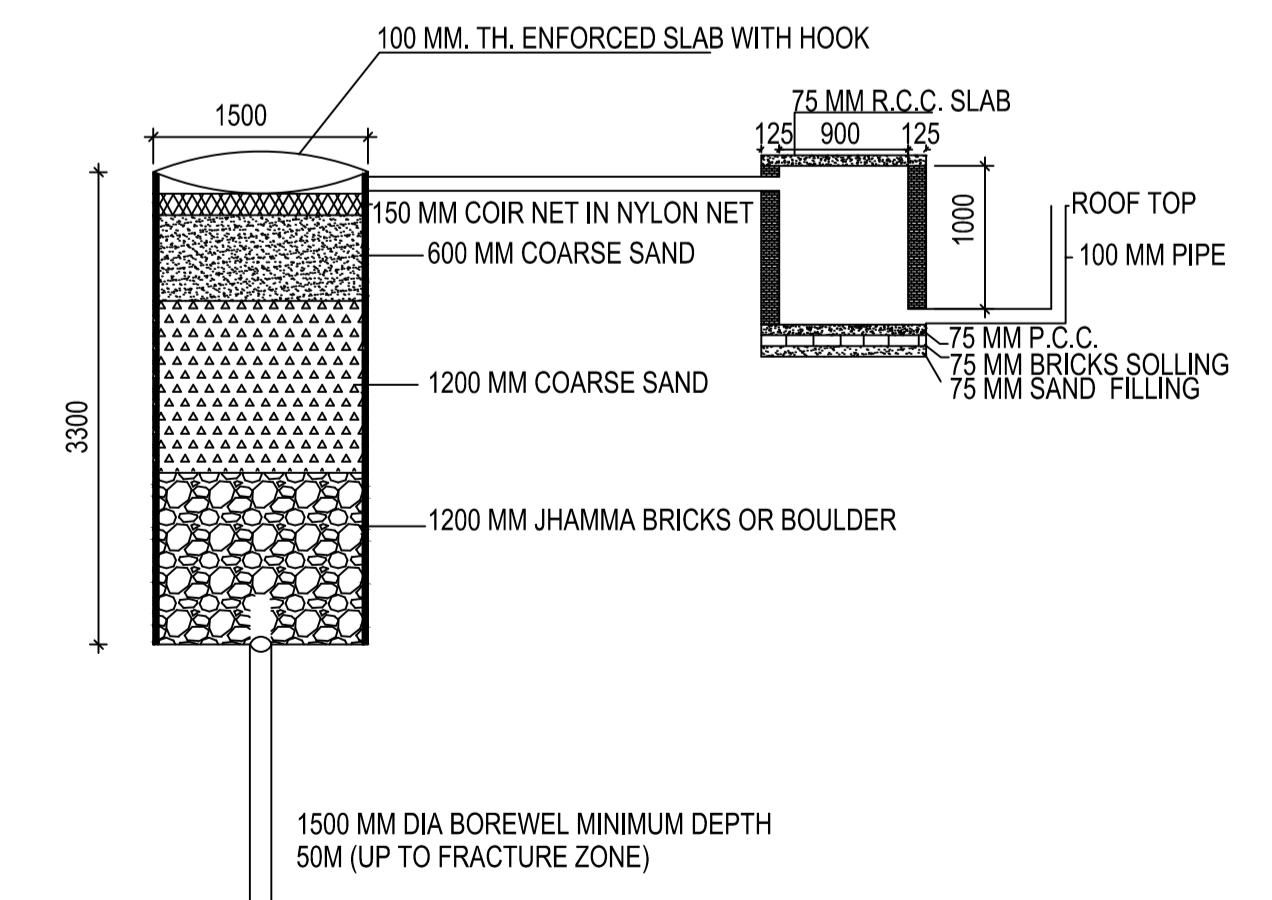
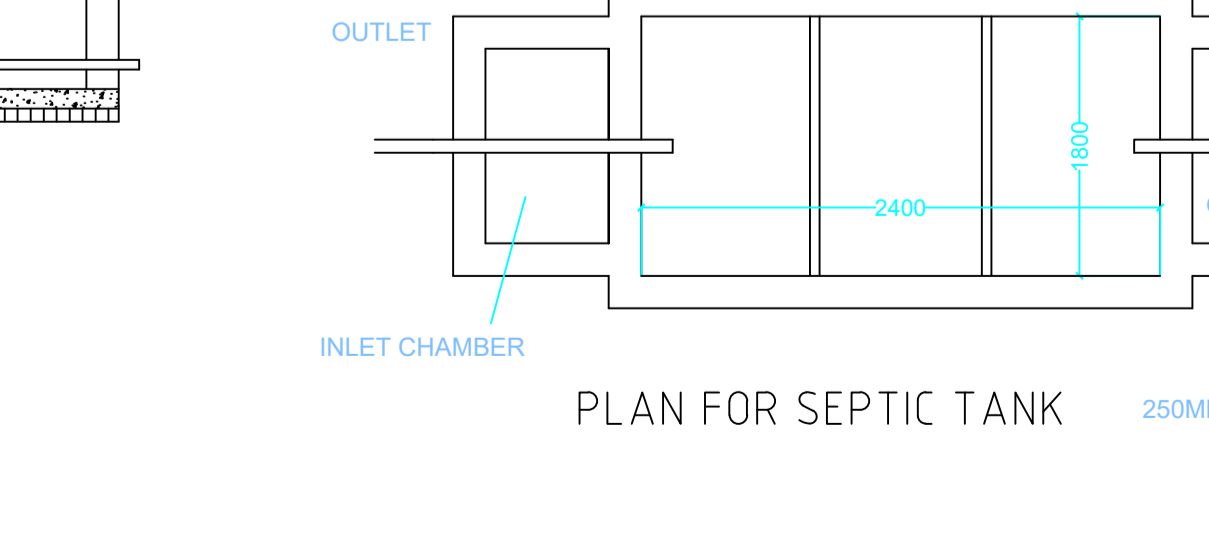
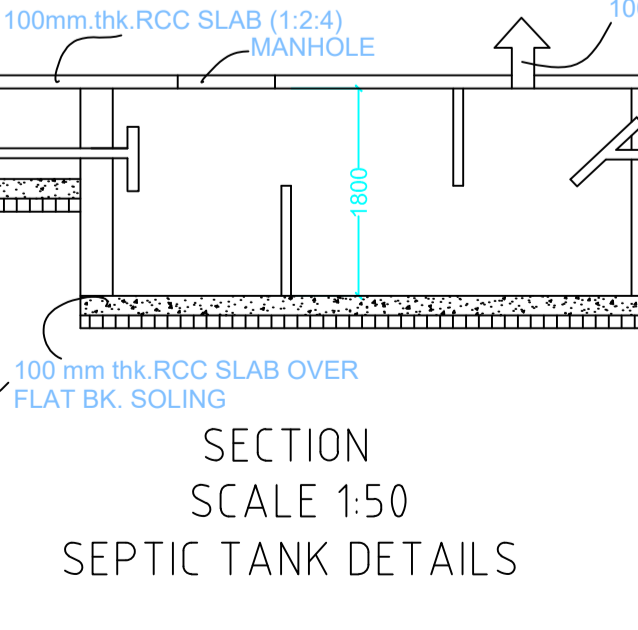
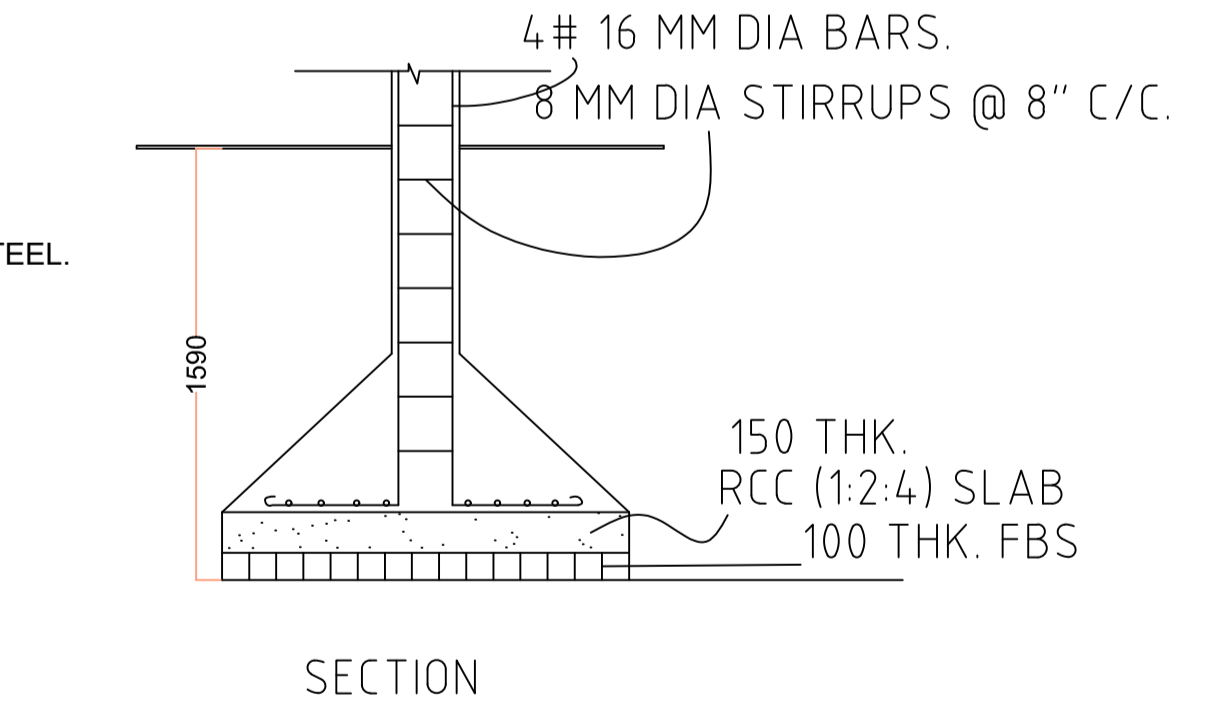
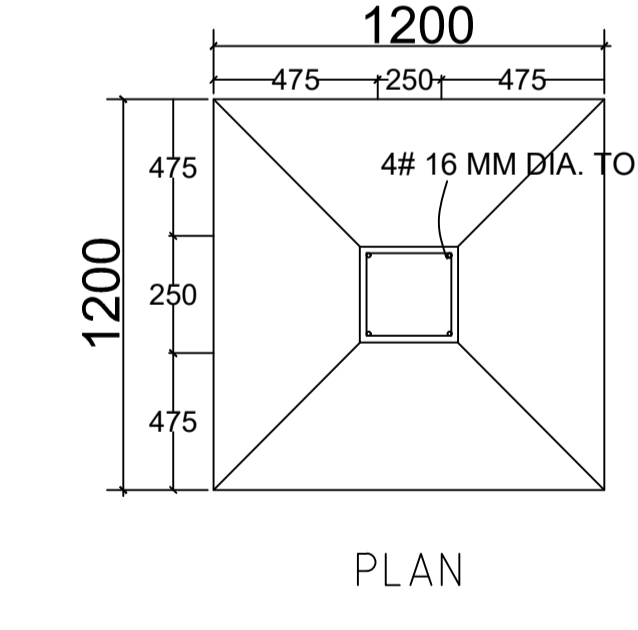
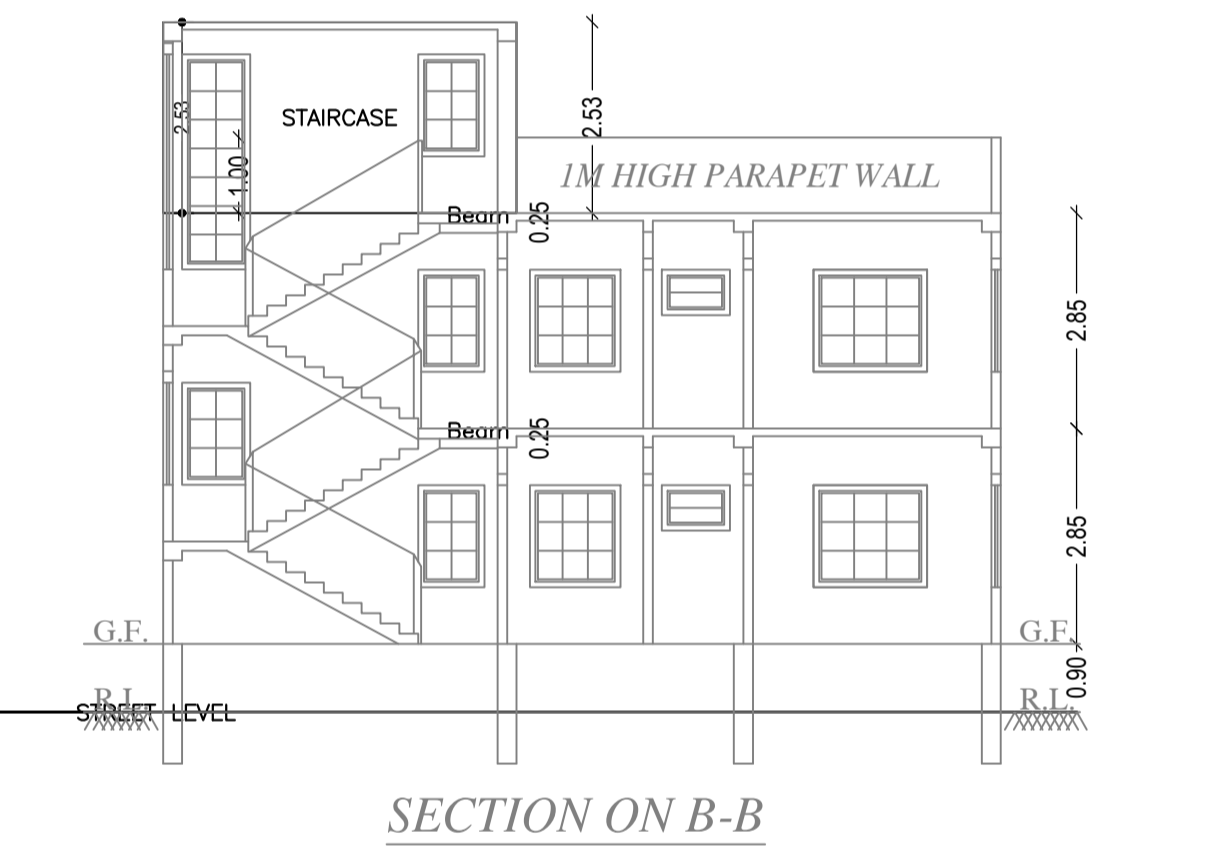
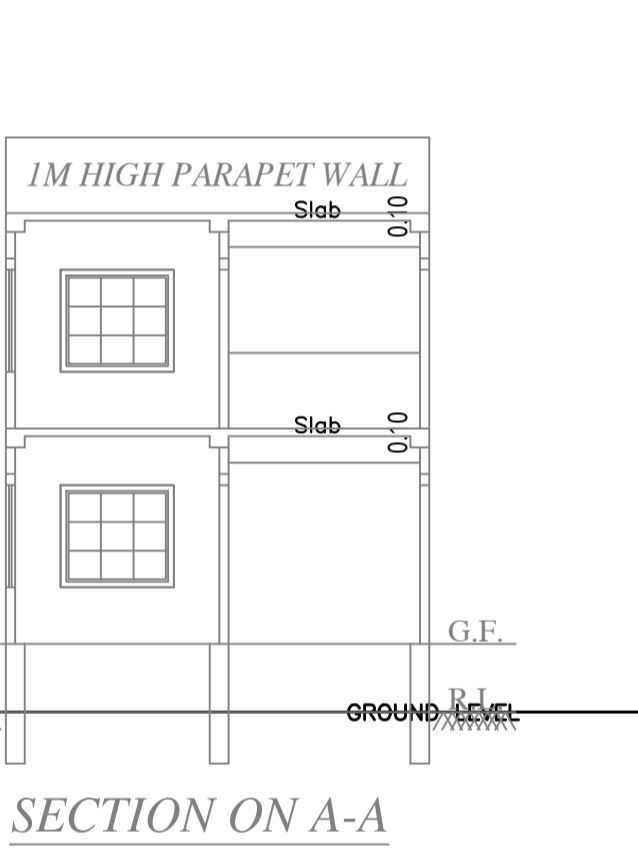

DETAIL OF GROUND WATER RECHARGING PIT WITH SILT TANK SCALE - N.T.S.

LTP NAME AND SIGNATURE	STRUCTURAL ENG'S NAME AND SIGNATURE	BUILDER NAME AND SIGNATURE	DIGITAL SIGNATURE
RAKISHOR KUMAR MNP/ENG/0003/2018			