

GROUND FLOOR PLAN (Proposed) (SCALE 1:100)

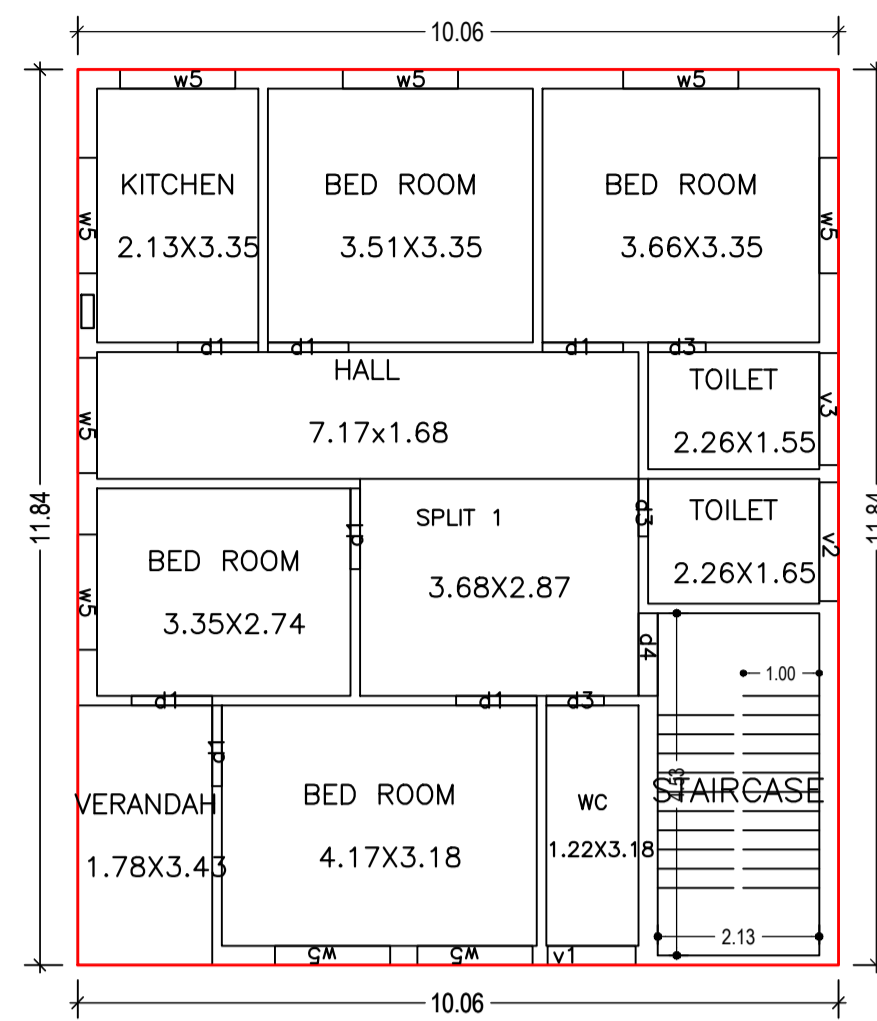

FIRST FLOOR PLAN (Proposed) (SCALE 1:100)

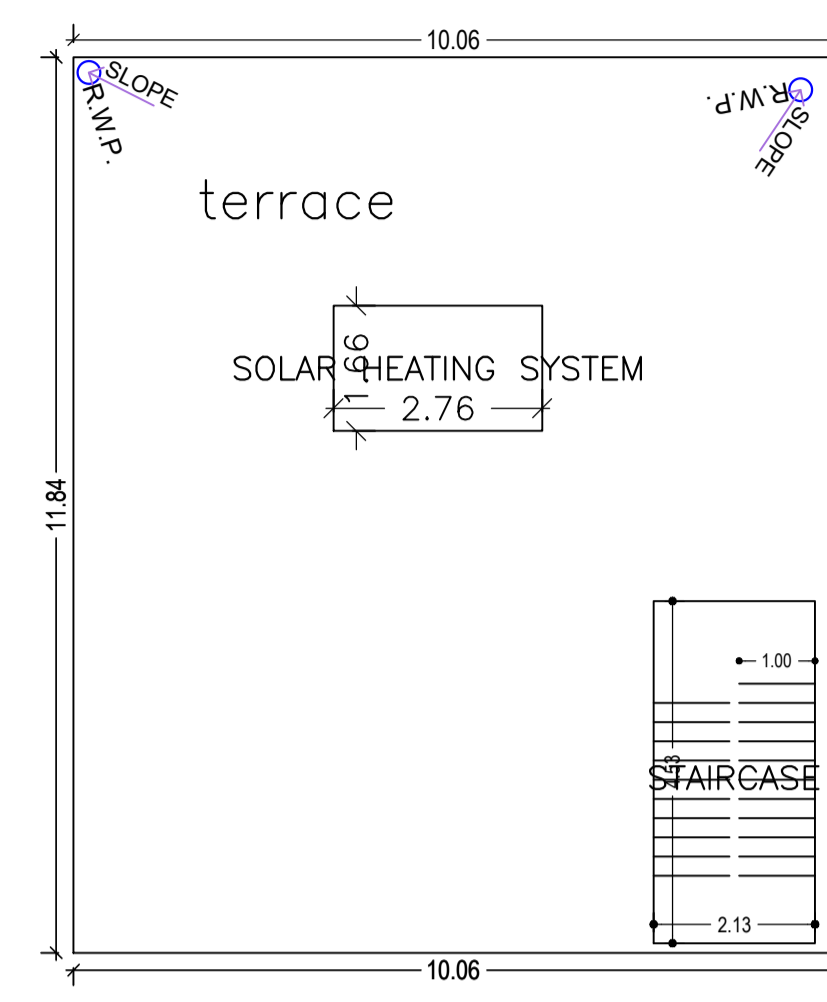

TERRACE FLOOR PLAN (SCALE 1:100)

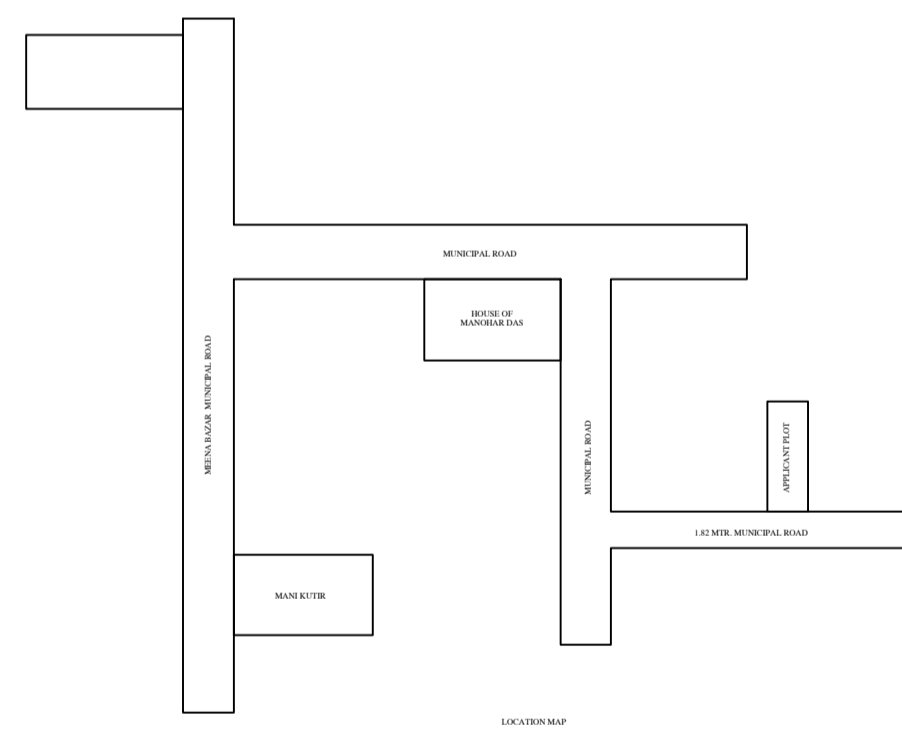
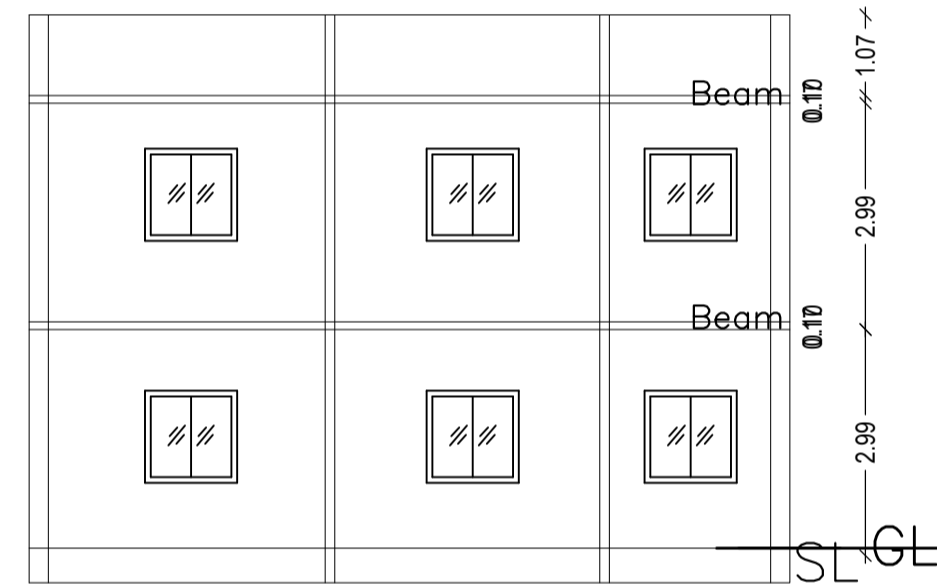
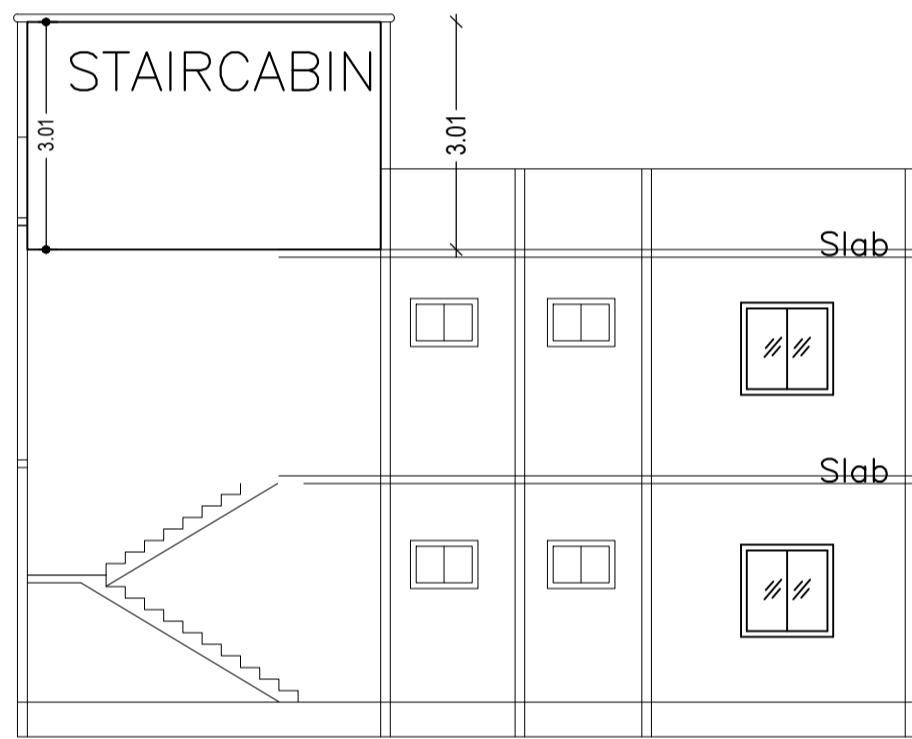

SITE PLAN

Building :A (1)

Floor Name	Total Built Up Area (Sq.mt.)	Proposed FAR Area (Sq.mt.)	Total FAR Area (Sq.mt.)	Total Consumed Additional FAR Area (Sq.mt.)	Trmt (No.)
Ground Floor	119.18	119.18	119.18	119.18	01
First Floor	119.18	119.18	119.18	119.18	00
Terrace Floor	0.00	0.00	0.00	0.00	00
Total :	238.36	238.36	238.36	238.36	01
Total Number of Same Buildings :	1				
Total :	238.36	238.36	238.36	238.36	01

SCHEDULE OF DOOR:

BUILDING NAME	NAME	LENGTH	HEIGHT	NOS
A (1)	d3	0.76	2.10	06
A (1)	d1	1.07	2.10	14
A (1)	d4	1.09	2.10	02

SCHEDULE OF WINDOW/VENTILATION:

BUILDING NAME	NAME	LENGTH	HEIGHT	NOS
A (1)	v1	1.16	0.45	02
A (1)	v3	1.48	0.45	02
A (1)	w5	1.52	1.20	18
A (1)	v2	1.57	0.45	02

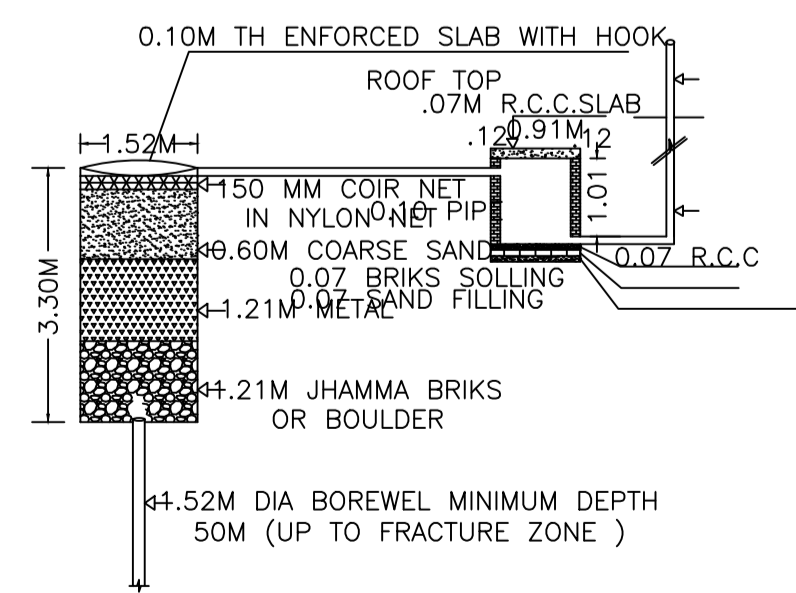

DETAIL OF GROUND WATER RECHARGING PIT WITH SILT TANK NOT TO SCALE

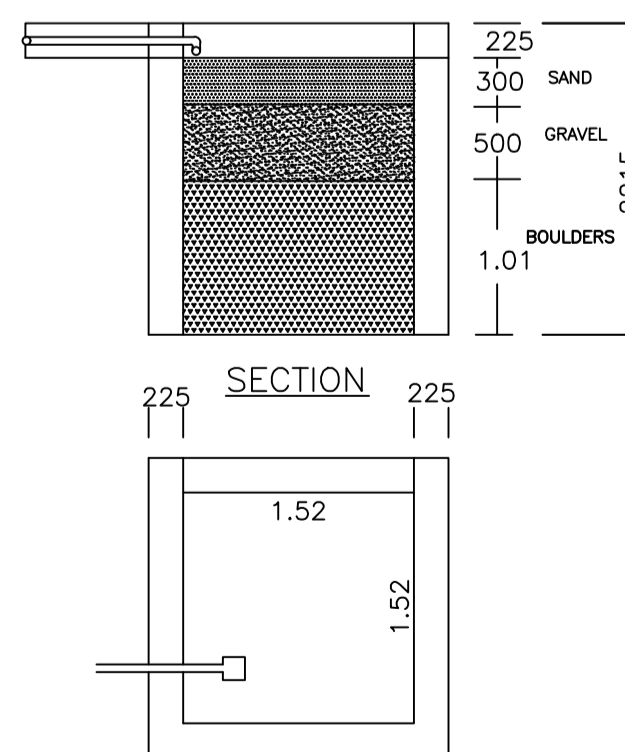

PLAN OF RAIN WATER HARVESTING (SCALE:-1:25)

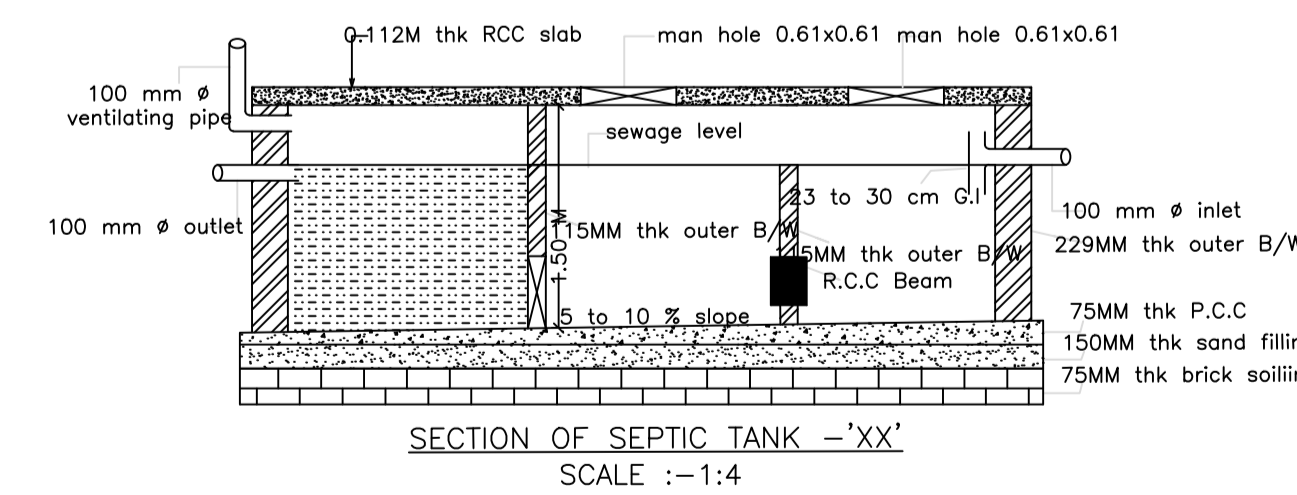

SECTION OF SEPTIC TANK -'XX'

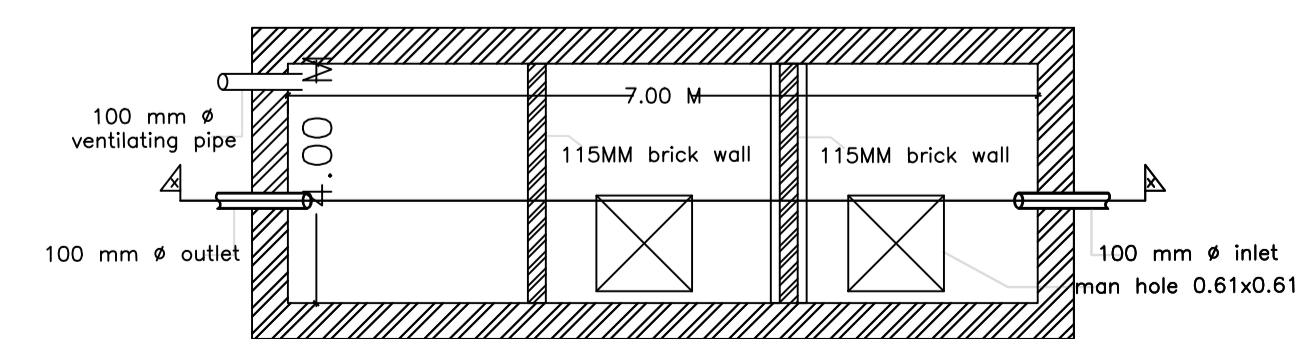

PLAN OF SEPTIC TANK

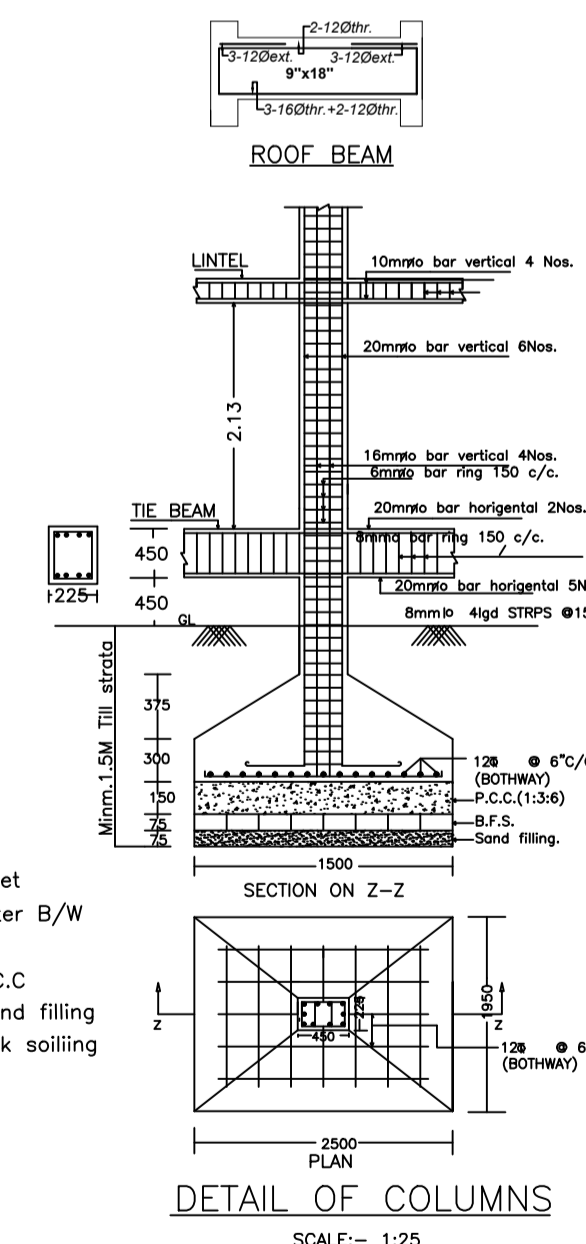

DETAIL OF COLUMNS (SCALE:- 1:25)

Proposal Basic Information

Proposal File No.	MNP/IB/0056/W21/2023
Owner Name	CHANDA DEVI
Khata No	2201/KA/1/2
Plot No	46
Village Name	Patharchptti
Use	Residential
SubUse	Bungalow/ Dwelling / Non Apartment

AREA STATEMENT	VERSION NO. : 1.0.66	
MADHUPUR NAGAR PARISHAD	VERSION DATE: 16/10/2020	
PROJECT DETAIL:		
Region: JHARKHAND URBAN LOCAL BODIES	Plot Use: Residential	
District: DEOGHAR	Plot SubUse: Bungalow/ Dwelling / Non Apartment	
Authority: MADHUPUR NAGAR PARISHAD	PlotNearby/ReligiousStructure: NA	
Inward No: MNP/IB/0056/W21/2023	Plot/SubPlot No: 46	
Application Type: General Proposal	North: Road Width - 1.82	
Project Type: Building Permission	South: Plot No. - LAND OF MANOJ PASWAN	
Nature of Development: New	East: Plot No. - HOUSE OF C.K TIWARI	
Location of Development Area: Old Area	West: Plot No. - LAND OF N. K MAJUMDAR	
AREA DETAILS:		
AREA OF PLOT (Minimum)	(A)	SQ.MT.
Deduction for NetPlot Area		209.68
Surrender Free of Cost		11.25
Total		11.25
NET AREA OF PLOT(Gross Plot Area - Deduction from Gross Plot area)	(A-Deductions)	198.43
Deduction for Balance Plot Area(from Gross Plot Area)		
Surrender Free of Cost		11.25
Common Plot		19.96
Total		31.21
BALANCE AREA OF PLOT(Net Plot Area - Recreational/Amenity space)	(A-Deductions)	178.47
PLOT AREA FOR COVERAGE(Net Plot Area)	(A-Deductions)	198.43
Plot Area for FAR (Net Plot Area + RoadWidening Area)	(A-Deductions)	209.68
COVERAGE CHECK		
Permissible Coverage area (70.00 %)		138.90
Proposed Coverage Area (60.06 %)		119.18
Total Prop. Coverage Area (60.06 %)		119.18
Balance coverage area (9.94 %)		19.72
FAR CHECK		
Perm. FAR Area (1.200)		251.62
Total Perm. FAR area		251.62
Residential FAR		238.37
Proposed FAR Area		238.37
Total Proposed FAR Area		238.37
Consumed FAR (Factor)		1.14
Balance FAR Area		13.25
BUILT UP AREA CHECK		
Total Proposed BuiltUp Area		238.36
ARCHITECT (Regd)		RAJKISHOR KUMAR
ENGINEER (Regd)		
SUPERVISOR (Regd)		
OWNER (Regd)		CHANDA DEVI
DEVELOPMENT AUTHORITY		LOCAL BODY

COLOR INDEX

PLOT BOUNDARY	Black
ABUTTING ROAD	Green
PROPOSED CONSTRUCTION	Red
COMMON PLOT	Yellow
ROAD WIDENING AREA	Blue
EXISTING (To be retained)	White
EXISTING (To be demolished)	Grey

Buildingwise Floor FAR Details

Floor Name	Building Name A (1)		Total	
	Proposed Built Up Area (Sq.mt.)	Proposed FAR Area (Sq.mt.)	Total Proposed Built Up Area (Sq.mt.)	Total FAR Area (Sq.mt.)
Ground Floor	119.18	119.18	119.18	119.18
First Floor	119.18	119.18	119.18	119.18
Terrace Floor	0.00	0.00	0.00	0.00
Total :	238.36	238.36	238.36	238.36

Building USE/SUBUSE Details

Building Name	Building Use	Building SubUse	Building Structure
A (1)	Residential	Bungalow/ Dwelling / Non Apartment	Non-Highrise

FAR & Tenement Details (Table 4c-1)

Building	No. of Same Bldg	Total Built Up Area (Sq.mt.)	Proposed FAR Area (Sq.mt.)	Total FAR Area (Sq.mt.)	Total Consumed Additional FAR Area (Sq.mt.)	Trmt (No.)
A (1)	1	238.36	238.36	238.36	238.36	01
Grand Total :	1	238.36	238.36	238.36	238.36	01

UnitBUA Table for Building :A (1)

FLOOR	Name	UnitBUA Type	UnitBUA Area	Carpet Area	No. of Rooms	No. of Tenement
GROUND FLOOR PLAN	SPLIT 1	FLAT	238.37	238.22	10	1
FIRST FLOOR PLAN	SPLIT 1	FLAT	0.00	0.00	10	0
Total			238.37	238.22	20	1

LTP NAME AND SIGNATURE	STRUCTURAL ENG'S NAME AND SIGNATURE	BUILDER NAME AND SIGNATURE	DIGITAL SIGNATURE
RAJKISHOR KUMAR MNP/ENG/0003/2018			