

Proposal Basic Information	
Proposal File No.	MNP/0023/W21/2024
Owner Name	KOUSHAL KISHOR
Khata No	220/1
Plot No	0/1
Village Name	Patharchptti
Use	Residential
SubUse	Bungalow/ Dwelling / Non Apartment

AREA STATEMENT		VERSION NO. : 1.0.71
MADHUPUR NAGAR PARISHAD		VERSION DATE: 16/10/2020
PROJECT DETAIL:		
Region: JHARKHAND URBAN	Plot Use: Residential	
LOCAL BODIES	Plot SubUse: Bungalow/ Dwelling / Non Apartment	
District: DEOGHAR	PlotNearby/ReligiousStructure: NA	
Authority: MADHUPUR NAGAR PARISHAD	Plot/SubPlot No: 0/1	
Inward_No: MNP/0023/W21/2024	North: Road Width - 3.35	
Application Type: General Proposal	South: Plot No. - PLOT NO 33 &42	
Project Type: Building Permission	East: Plot No. - SUB PLOT B AND LAND OF MANI SHANKAR	
Nature of Development: New	West: Road Width - 3.35	
Location of Development Area: Old Area		

AREA DETAILS:		SQ. MT.
AREA OF PLOT (Minimum)	(A)	236.10
NET AREA OF PLOT(Gross Plot Area - Deduction from Gross Plot area)	(A-Deductions)	236.10
Deduction for Balance Plot Area(from Gross Plot Area)		
Common Plot		29.24
Total		29.24
BALANCE AREA OF PLOT(Net Plot Area - Recreational/Amenity space)	(A-Deductions)	206.86
PLOT AREA FOR COVERAGE(Net Plot Area)	(A-Deductions)	236.10
Plot Area for FAR (Net Plot Area + RoadWidening Area)	(A-Deductions)	236.10

COVERAGE CHECK		
Permissible Coverage area (60.00 %)		141.66
Proposed Coverage Area (48.85 %)		115.33
Total Prop. Coverage Area (48.85 %)		115.33
Balance coverage area (11.15 %)		26.33
FAR CHECK		
Perm. FAR Area (1.500)		354.15
Total Perm. FAR area		354.15
Residential FAR		115.33
Proposed FAR Area		115.33
Total Proposed FAR Area		115.33
Consumed FAR (Factor)		0.49
Balance FAR Area		238.82
BUILT UP AREA CHECK		
Total Proposed BuiltUp Area		115.33
ARCHITECT (Regd)	VISHAL YADAV	
ENGINEER (Regd)		
SUPERVISOR (Regd)		
OWNER (Regd)	KOUSHAL KISHOR	
DEVELOPMENT AUTHORITY		LOCAL BODY

COLOR INDEX	
PLOT BOUNDARY	Black
ABUTTING ROAD	Green
PROPOSED CONSTRUCTION	Red
COMMON PLOT	Yellow
ROAD WIDENING AREA	Orange
EXISTING (To be retained)	Blue
EXISTING (To be demolished)	Light Blue

Floor Name	Building Name A (1)		Total	
	Proposed Built Up Area (Sq.mt.)	Proposed FAR Area (Sq.mt.)	Total Proposed Built Up Area (Sq.mt.)	Total FAR Area (Sq.mt.)
Ground Floor	115.33	115.33	115.33	115.33
Terrace Floor	0.00	0.00	0.00	0.00
Total :	115.33	115.33	115.33	115.33

Building USE/SUBUSE Details

Building Name	Building Use	Building SubUse	Building Structure	Floor Name	Floor Use	Floor SubUse	FAR Name	FAR Use	FAR SubUse
A (1)	Residential	Bungalow/ Dwelling / Non Apartment	Non-Highrise	GROUND FLOOR PLAN	Residential	Bungalow/ Dwelling / Non Apartment	Residential FAR	Residential	Bungalow/ Dwelling / Non Apartment
				TERRACE FLOOR PLAN	Residential	Bungalow/ Dwelling / Non Apartment	-	-	-

FAR & Tenement Details (Table 4c-1)

Building	No. of Same Bldg	Total Built Up Area (Sq.mt.)	Proposed FAR Area (Sq.mt.)	Total FAR Area (Sq.mt.)	Total Consumed Additional FAR Area (Sq.mt.)	Tnmt (No.)
A (1)	1	115.33	115.33	115.33	115.33	01
Grand Total :	1	115.33	115.33	115.33	115.33	01

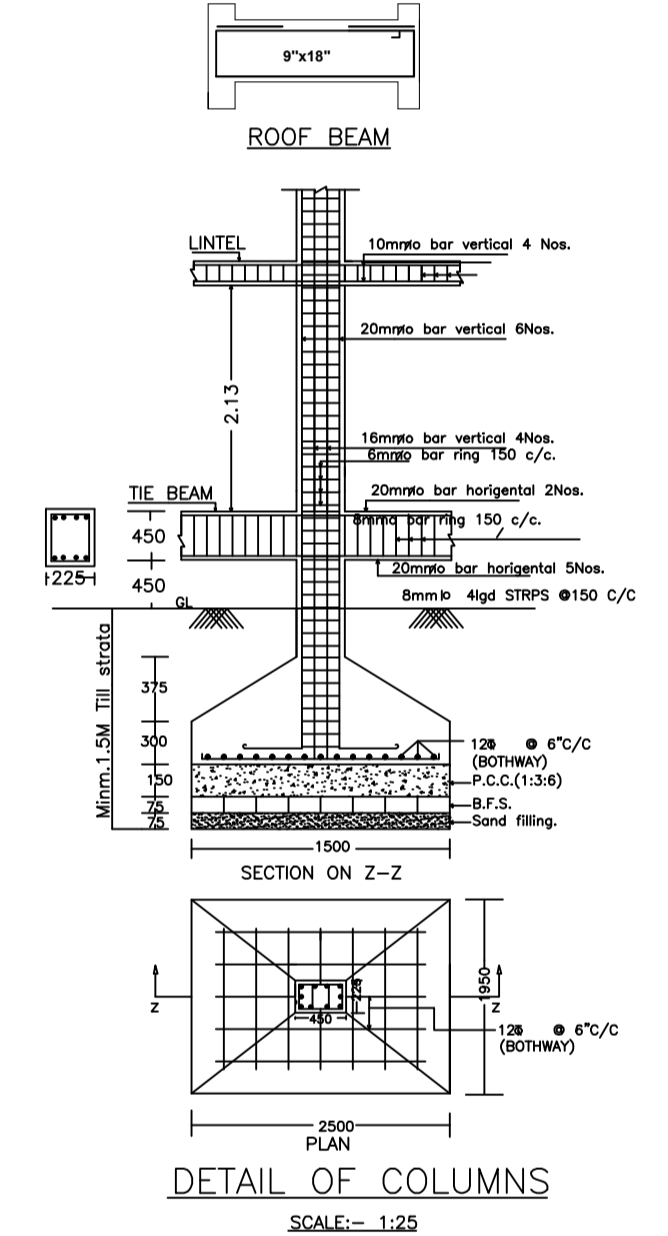
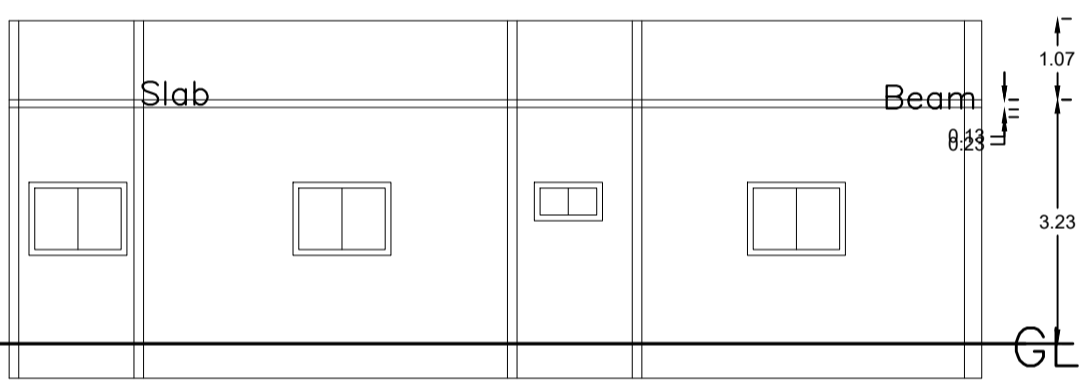
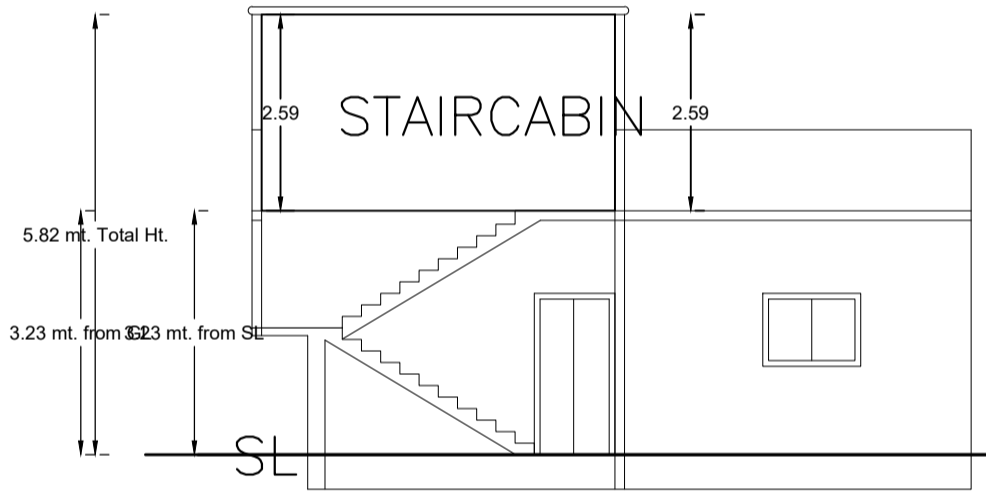
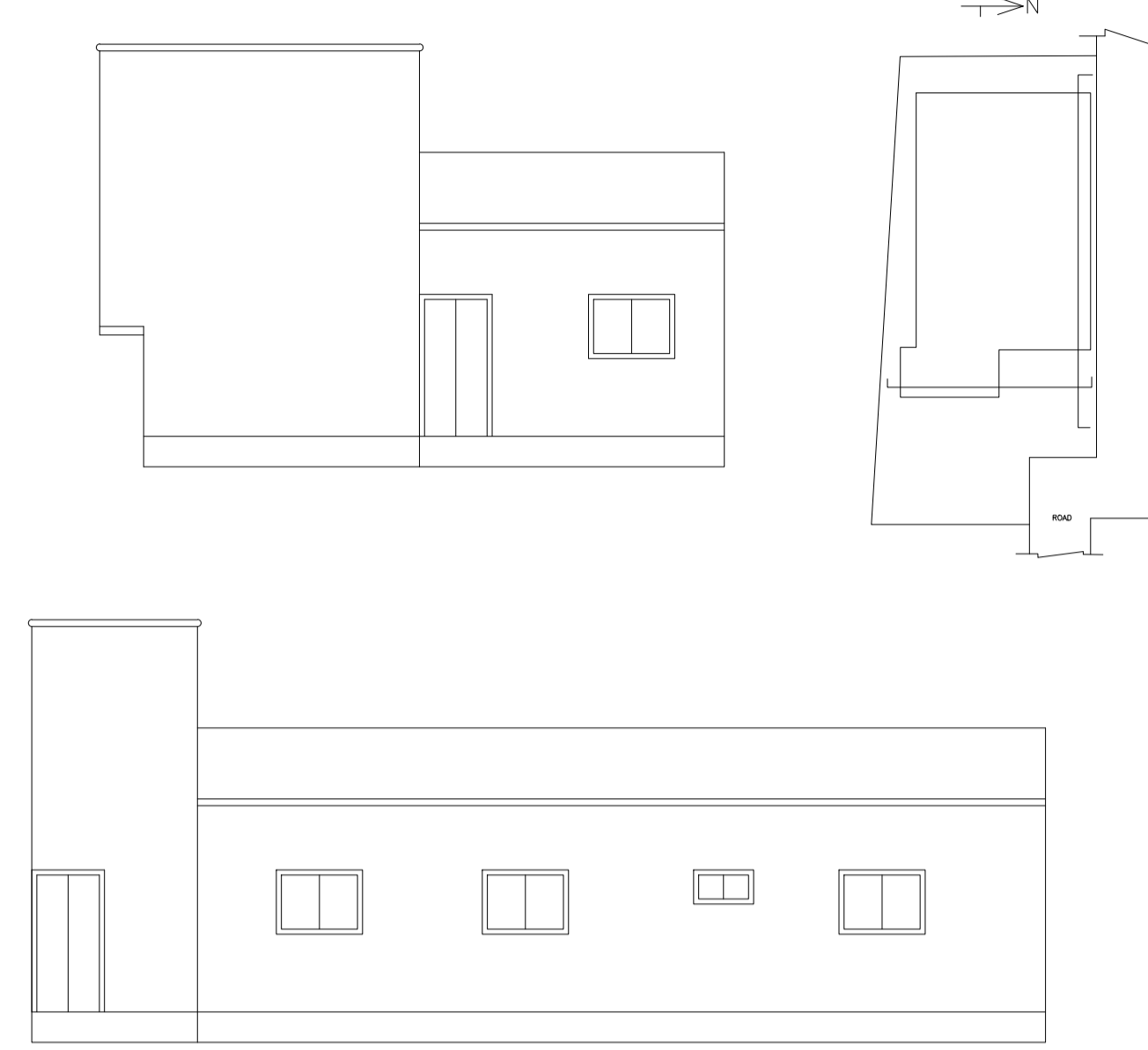
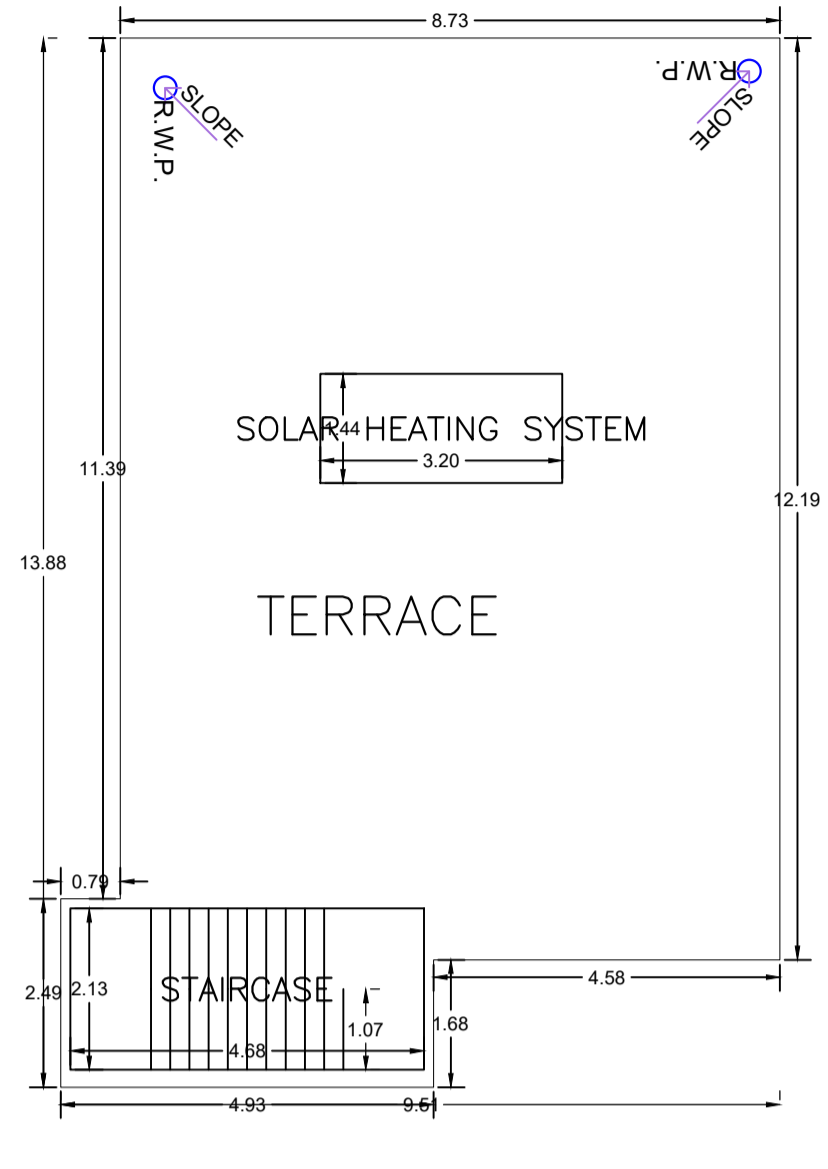
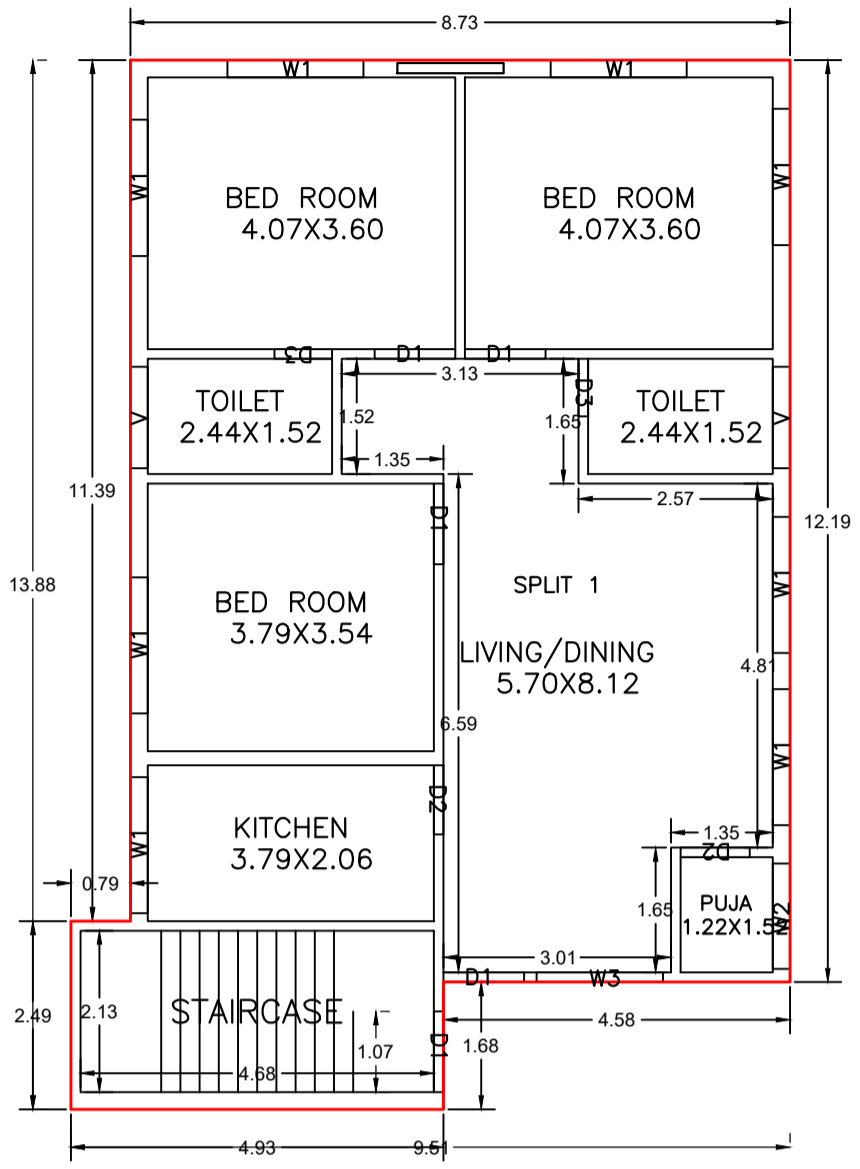
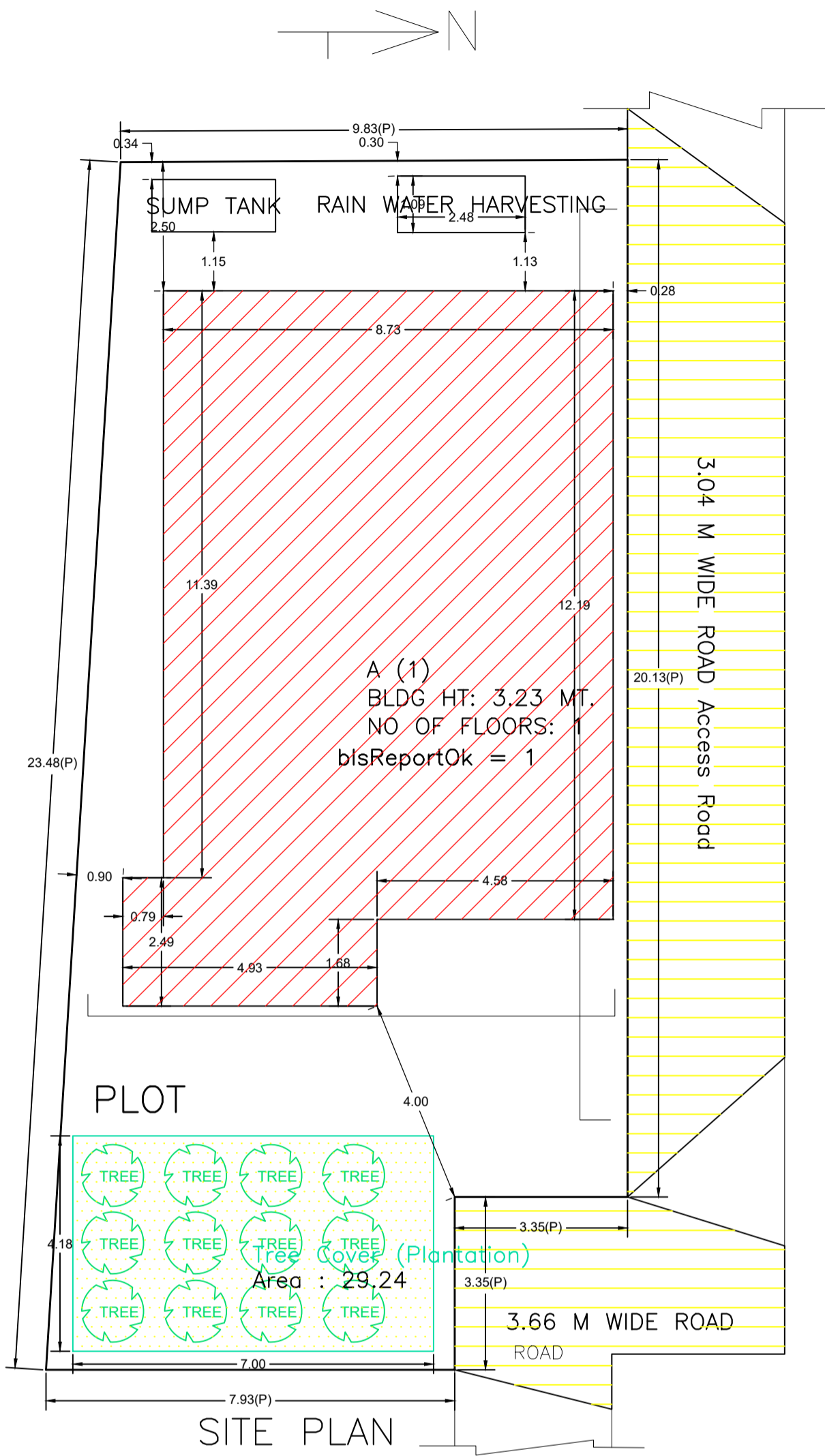

UnitBUA Table for Building :A (1)

FLOOR	Name	UnitBUA Type	UnitBUA Area	Carpet Area	No. of Rooms	No. of Tenement
GROUND FLOOR PLAN	SPLIT 1	FLAT	115.33	115.14	8	1
Total:	-	-	115.33	115.14	8	1

SCHEDULE OF DOOR:

BUILDING NAME	NAME	LENGTH	HEIGHT	NOS
A (1)	D3	0.76	2.10	02
A (1)	D2	0.91	2.10	02
A (1)	D1	1.07	2.10	04

SCHEDULE OF WINDOW/VENTILATION:

BUILDING NAME	NAME	LENGTH	HEIGHT	NOS
A (1)	V	1.34	0.45	02
A (1)	W2	1.40	1.20	01
A (1)	W3	1.67	1.20	01
A (1)	W1	1.80	1.20	08

Building :A (1)

Floor Name	Total Built Up Area (Sq.mt.)	Proposed FAR Area (Sq.mt.)	Total FAR Area (Sq.mt.)	Total Consumed Additional FAR Area (Sq.mt.)	Tnmt (No.)
Ground Floor	115.33	115.33	115.33	115.33	01
Terrace Floor	0.00	0.00	0.00	0.00	00
Total :	115.33	115.33	115.33	115.33	01
Total Number of Same Buildings :	1				
Total :	115.33	115.33	115.33	115.33	01

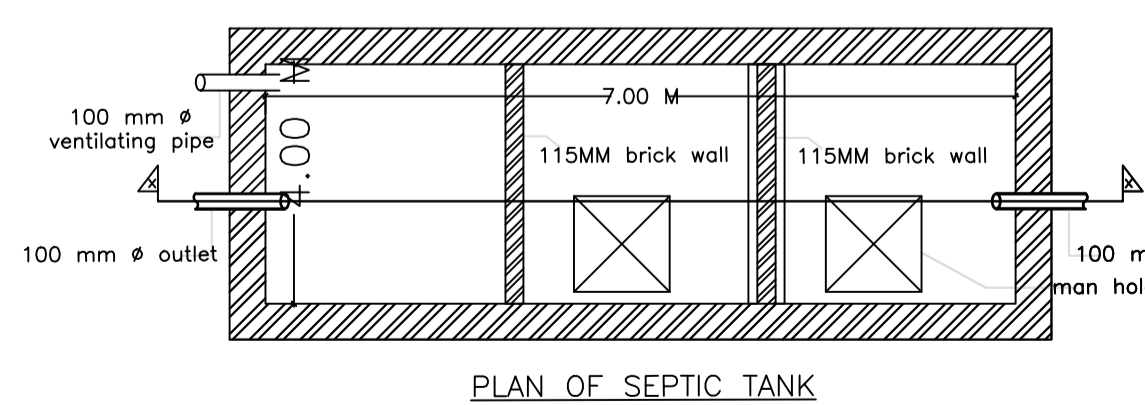
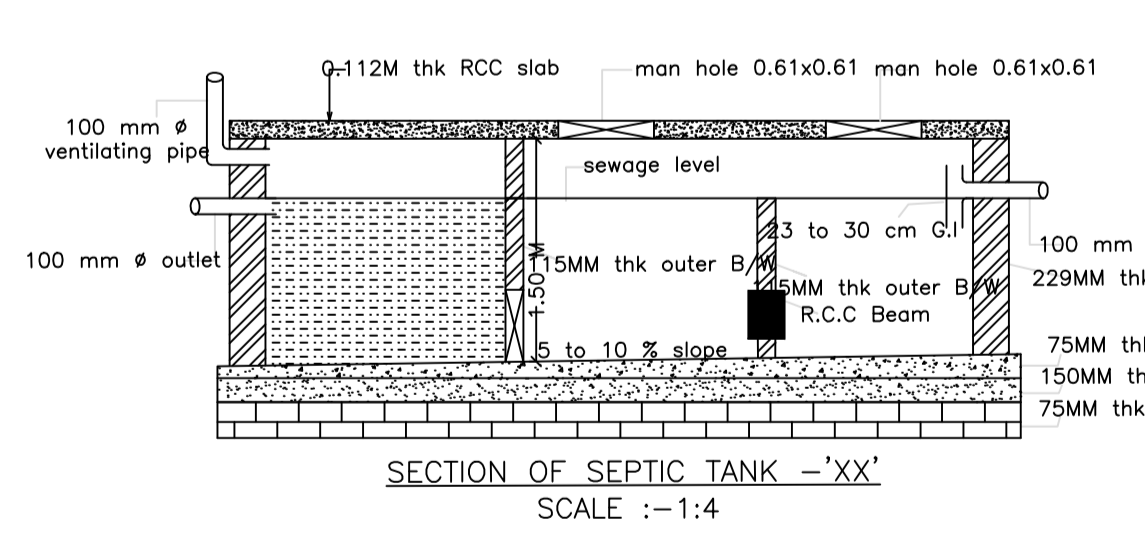
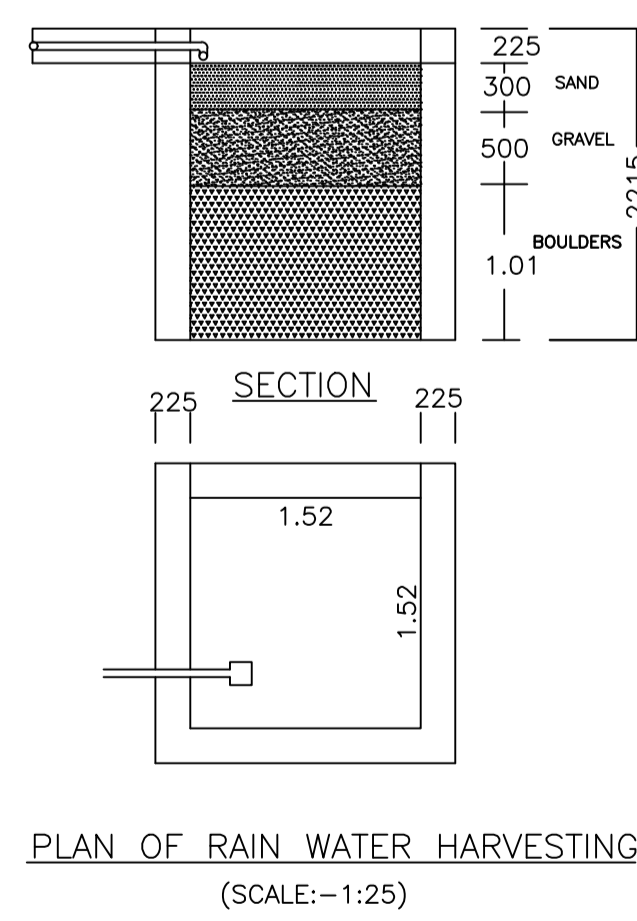
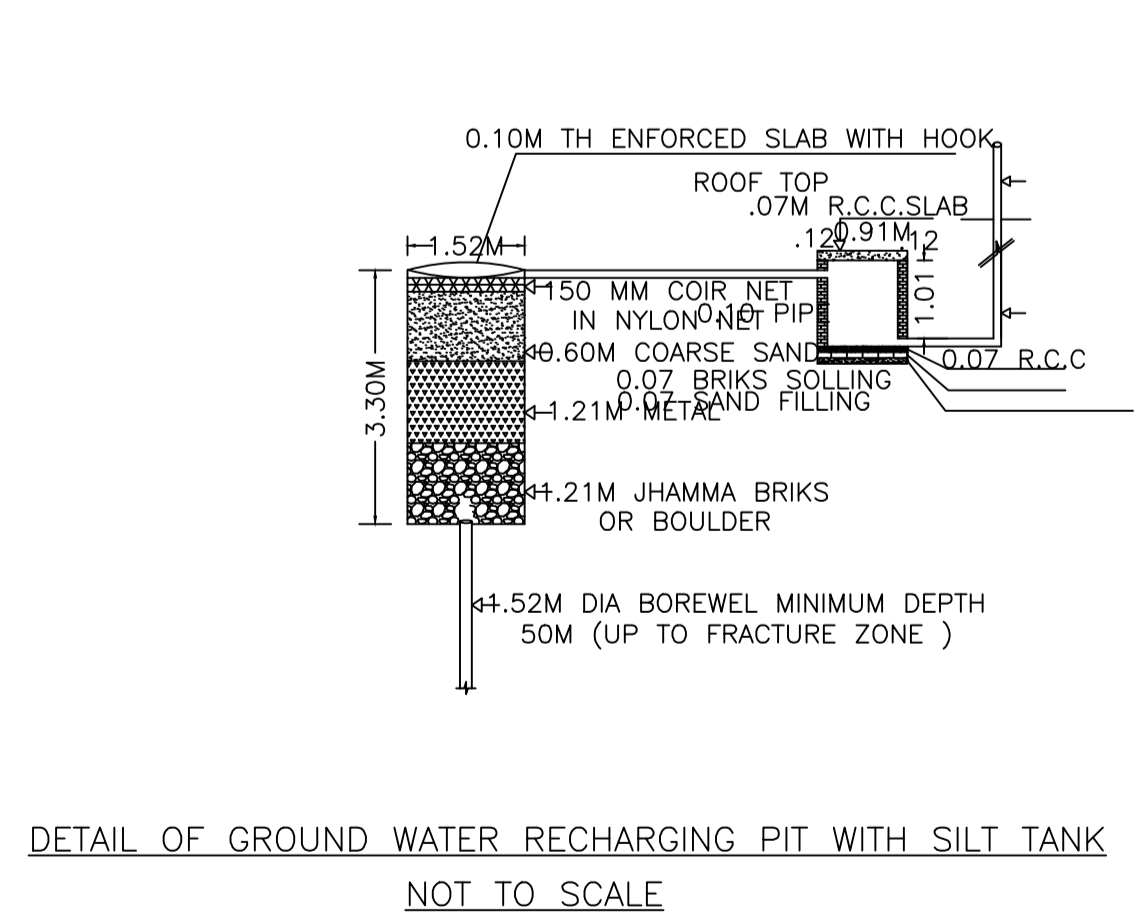

LTP NAME AND SIGNATURE	STRUCTURAL ENG'S NAME AND SIGNATURE	BUILDER NAME AND SIGNATURE	DIGITAL SIGNATURE
VISHAL YADAV MNP/ENG/0006/2020			