

Building :A (SMT PURNIMA DEVI)

Building USE/SUBUSE Details

Building Name	Building Use	Building SubUse	Building Structure
A (SMT PURNIMA DEVI)	Residential	Residential Bldg/Apartment	Non-Highrise

Floor Name	Total Built Up Area (Sq.mt.)	Proposed FAR Area (Sq.mt.) Resi.	Total FAR Area (Sq.mt.)	Total Consumed Additional FAR Area (Sq.mt.)	Tnmt (No.)
Ground Floor	62.26	62.26	62.26	62.26	01
Terrace Floor	0.00	0.00	0.00	0.00	00
Total :	62.26	62.26	62.26	62.26	01
Total Number of Same Buildings :	1				
Total :	62.26	62.26	62.26	62.26	01

COLOR INDEX

PLOT BOUNDARY
 ABUTTING ROAD
 PROPOSED CONSTRUCTION
 COMMON PLOT
 ROAD WIDENING AREA
 EXISTING (To be retained)
 EXISTING (To be demolished)

Buildingwise Floor FAR Details

Floor Name	Building Name		Total	
	Proposed Built Up Area (Sq.mt.)	Proposed FAR Area (Sq.mt.)	Total Proposed Built Up Area (Sq.mt.)	Total FAR Area (Sq.mt.)
Ground Floor	62.26	62.26	62.26	62.26
Terrace Floor	0.00	0.00	0.00	0.00
Total :	62.26	62.26	62.26	62.26

Proposal Basic Information

Proposal File No.	PNPC/BP/0017/W04/2018
Owner Name	PURNIMA DEVI
Khata No	552
Plot No	1350
Village Name	Pakur
Use	Residential
SubUse	Residential Bldg/Apartment

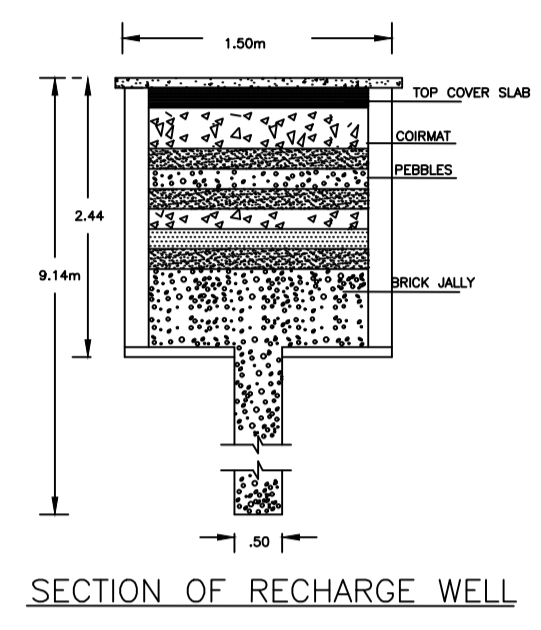
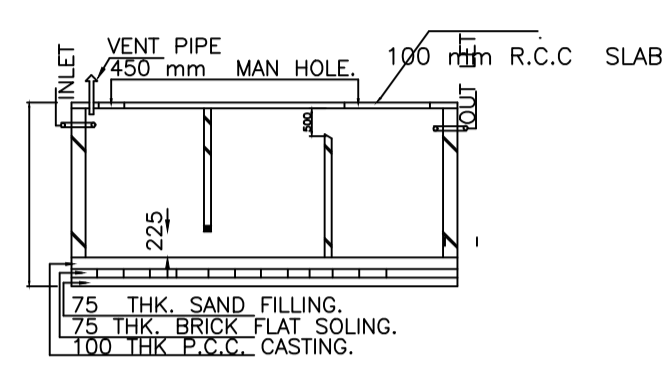
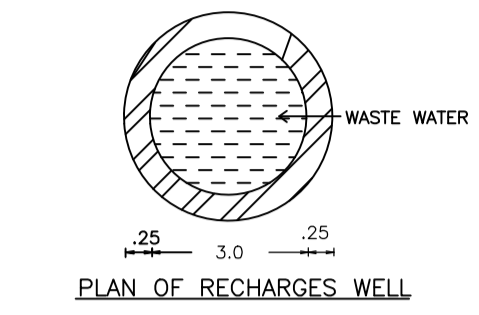
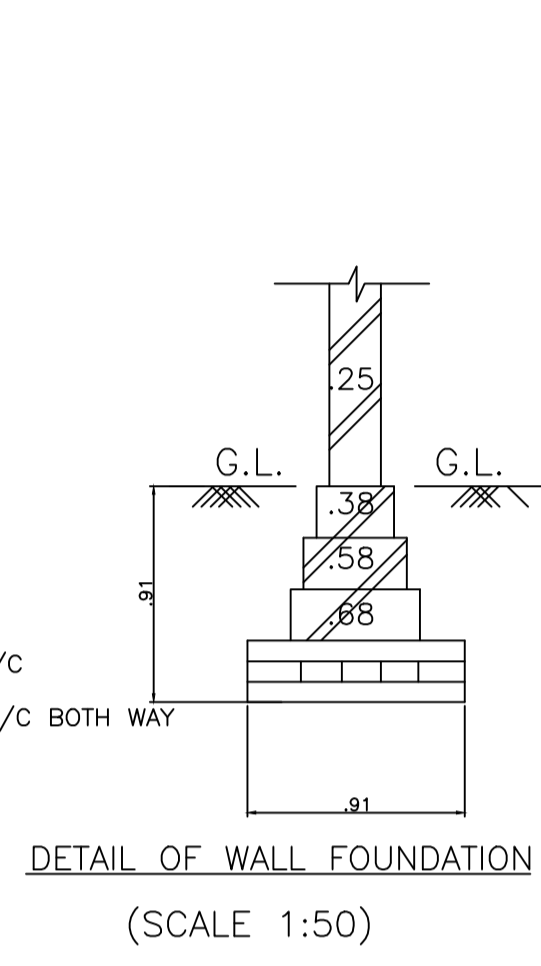
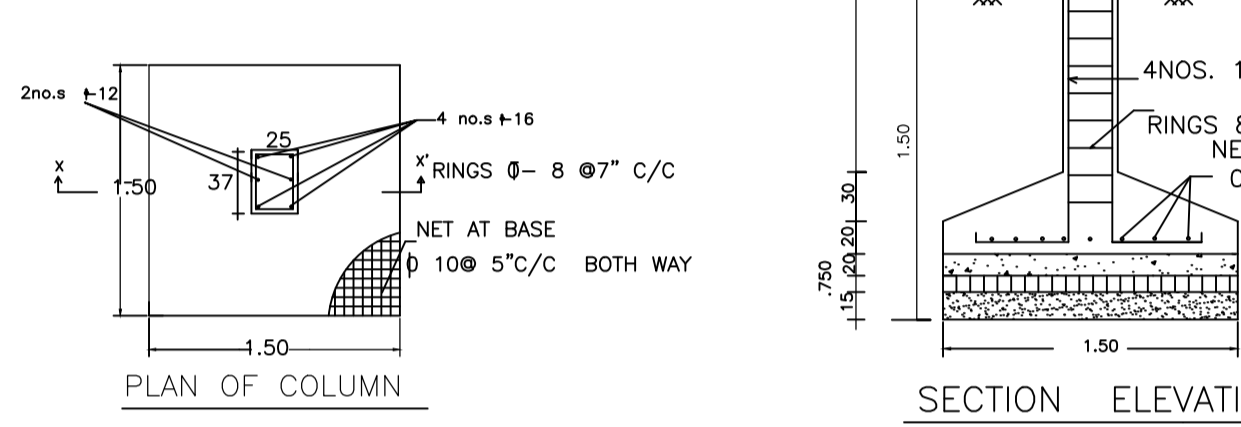
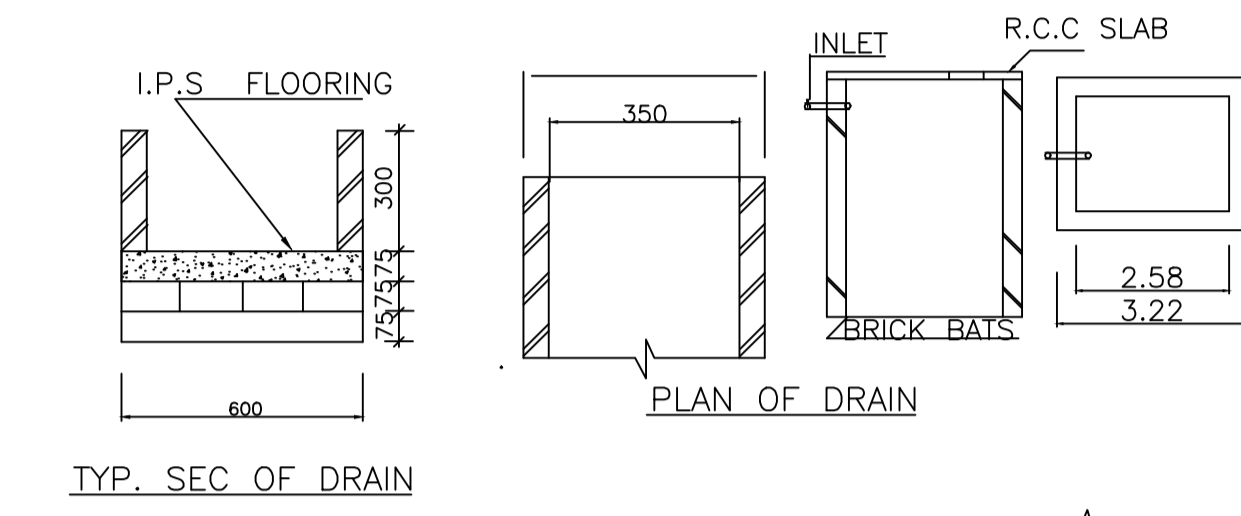

UnitBUA Table for Building :A (SMT PURNIMA DEVI)

FLOOR	Name	UnitBUA Type	UnitBUA Area	Carpet Area	No. of Rooms	No. of Tenement
GROUND FLOOR PLAN	SPLIT SMT PURNIMA DEVI	FLAT	43.23	43.04	3	1
Total:	-	-	43.23	43.04	3	1

FAR & Tenement Details (Table 4c-1)

Building	No. of Same Bldg	Total Built Up Area (Sq.mt.)	Proposed FAR Area (Sq.mt.) Resi.	Total FAR Area (Sq.mt.)	Total Consumed Additional FAR Area (Sq.mt.)	Tnmt (No.)
A (SMT PURNIMA DEVI)	1	62.26	62.26	62.26	62.26	01
Grand Total :	1	62.26	62.26	62.26	62.26	01

SCHEDULE OF DOOR:

BUILDING NAME	NAME	LENGTH	HEIGHT	NOS
A (SMT PURNIMA DEVI)	D2	0.75	2.13	01
A (SMT PURNIMA DEVI)	D1	0.90	2.13	01
A (SMT PURNIMA DEVI)	D1	1.07	2.13	01
A (SMT PURNIMA DEVI)	D0	1.07	2.13	01

SCHEDULE OF WINDOW/VENTILATION:

BUILDING NAME	NAME	LENGTH	HEIGHT	NOS
A (SMT PURNIMA DEVI)	V	0.76	1.50	01
A (SMT PURNIMA DEVI)	W1	1.20	2.50	01
A (SMT PURNIMA DEVI)	W	1.80	2.50	02
A (SMT PURNIMA DEVI)	W	2.38	2.50	01

AREA STATEMENT PAKUR NAGAR PARISHAD		VERSION NO. : 1.0.28
PROJECT DETAIL:		VERSION DATE: 30/08/2018
Region: JHARKHAND URBAN LOCAL BODIES	Plot Use: Residential	
District: PAKUR	Plot SubUse: Residential Bldg/Apartment	
Authority: PAKUR NAGAR PARISHAD	Plot/Nearby/Religious Structure: NA	
Inward No: PNP/CP/0017/W04/2018	Plot/SubPlot No: 1350	
Application Type: General Proposal	North: -	
Project Type: Building Permission	South: -	
Nature of Development: New	East: -	
Location of Development Area: Old Area	West: -	
AREA DETAILS:		SQ.MT.
AREA OF PLOT (Minimum)	(A)	134.08
NET AREA OF PLOT (Gross Plot Area - Deduction from Gross Plot area)	(A-Deductions)	134.08
Deduction for Balance Plot Area (from Gross Plot Area)		
Common Plot		19.37
Total		19.37
BALANCE AREA OF PLOT (Net Plot Area - Recreational/Amenity space)	(A-Deductions)	114.70
PLOT AREA FOR COVERAGE (Net Plot Area for FAR (Net Plot Area + Road/Widening Area))	(A-Deductions)	134.08
COVERAGE CHECK		
Permissible Coverage Area (70.00 %)		93.86
Proposed Coverage Area (46.44 %)		62.26
Total Prop. Coverage Area (46.44 %)		62.26
Balance coverage area (23.57 %)		31.60
FAR CHECK		
Perm. FAR Area (1.20)		160.90
Total Perm. FAR area		160.90
Residential FAR		62.26
Proposed FAR Area		62.26
Total Proposed FAR Area		62.26
Consumed FAR (Factor)		0.46
Balance FAR Area		98.64
BUILT UP AREA CHECK		
Total Proposed Built Up Area		62.26
ARCHITECT (Regd)	SHYAM DUTT SHUKLA	
ENGINEER (Regd)		
SUPERVISOR (Regd)	PURNIMA DEVI	
OWNER (Regd)		
DEVELOPMENT AUTHORITY	LOCAL BODY	

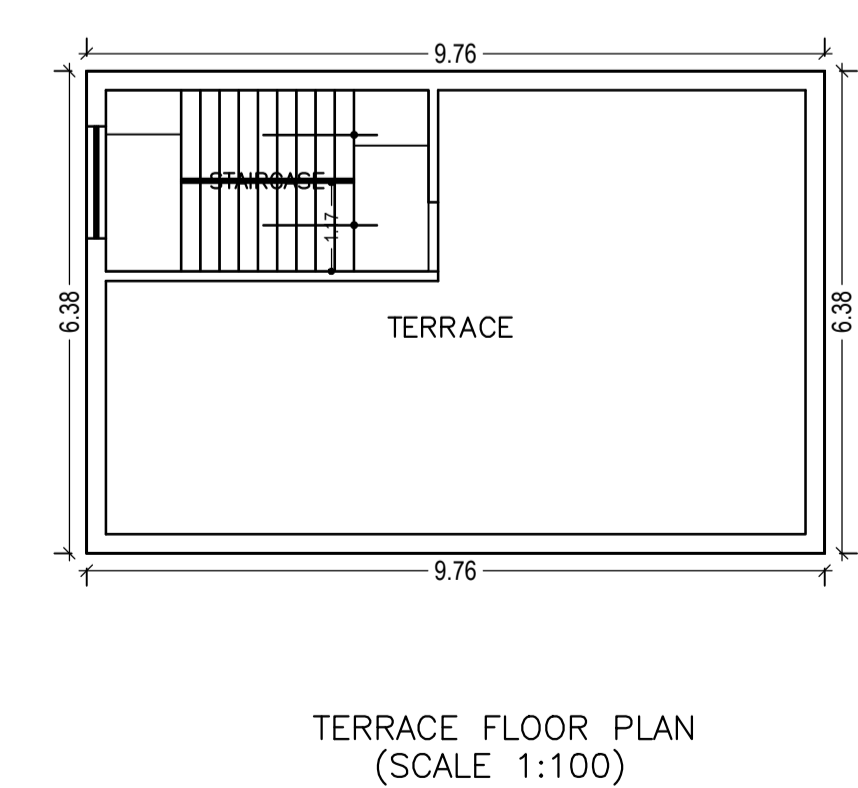
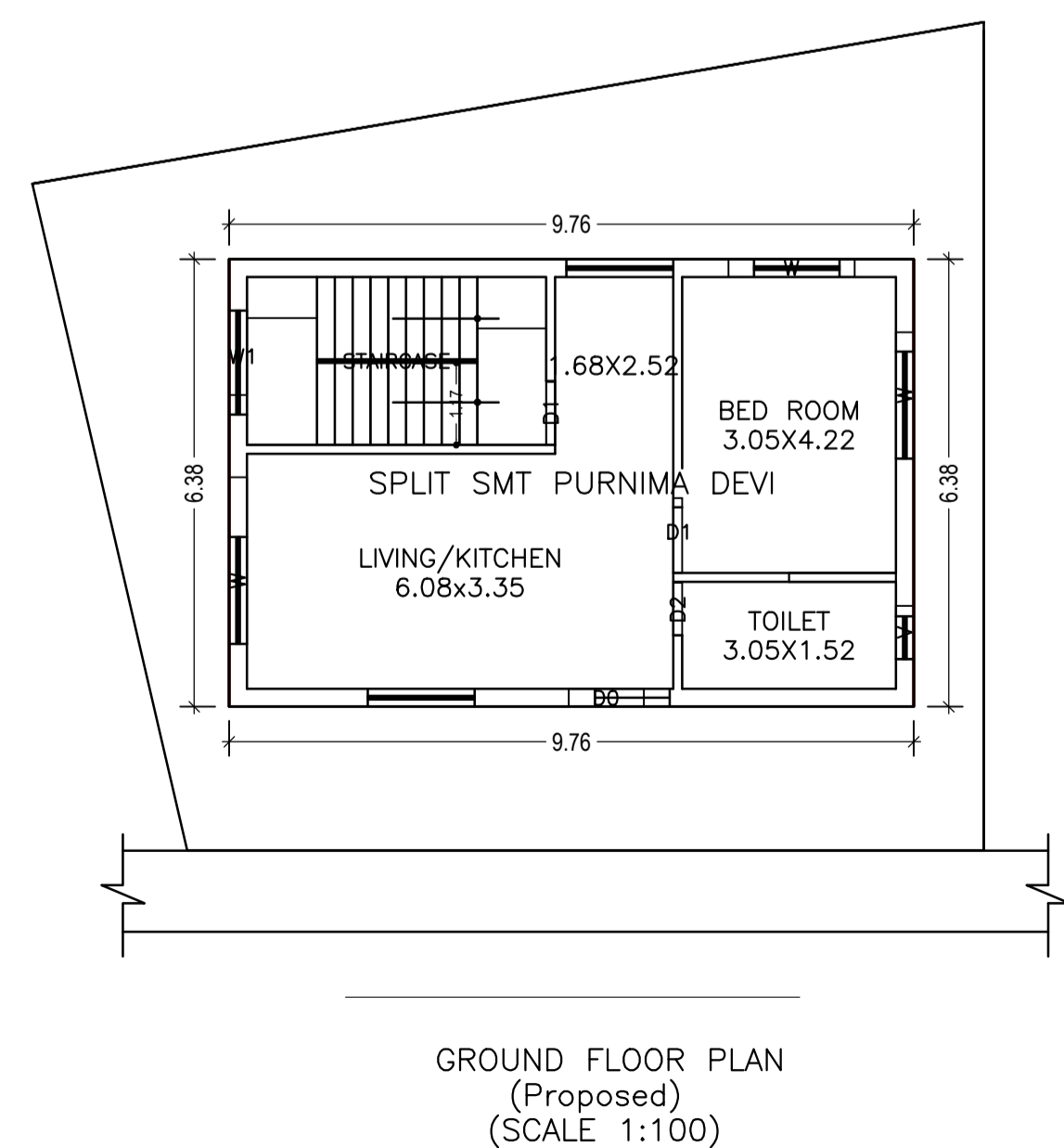
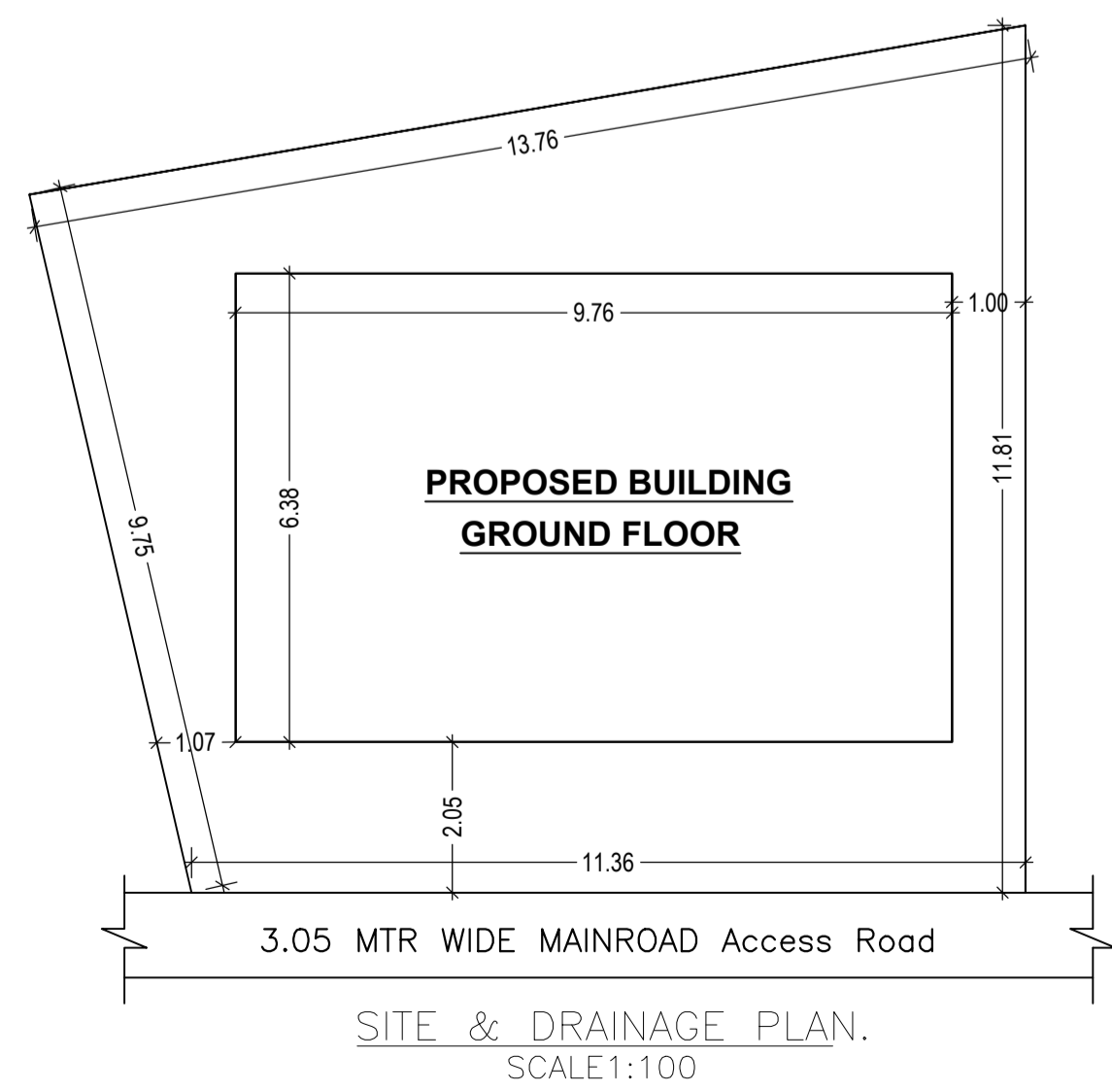
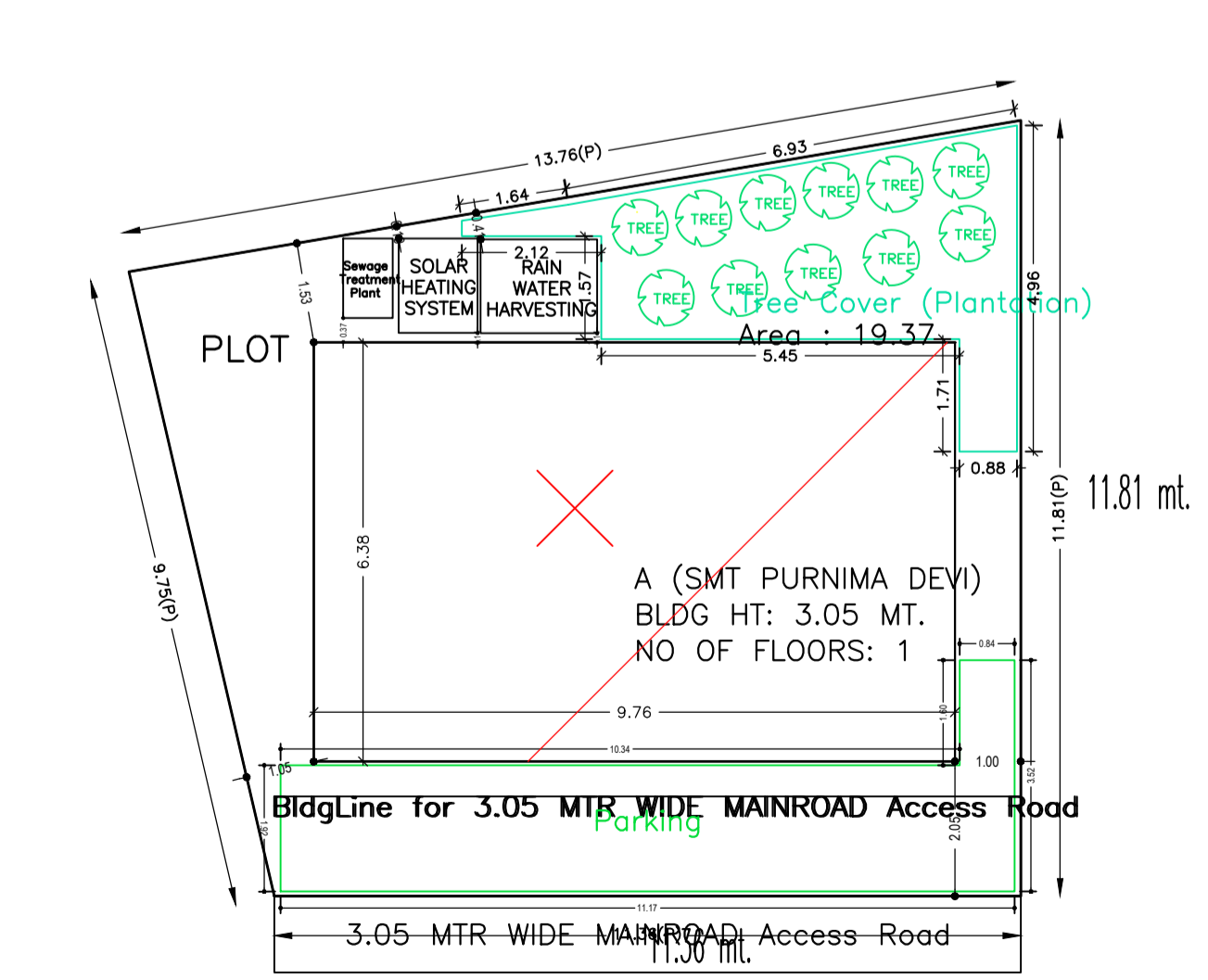
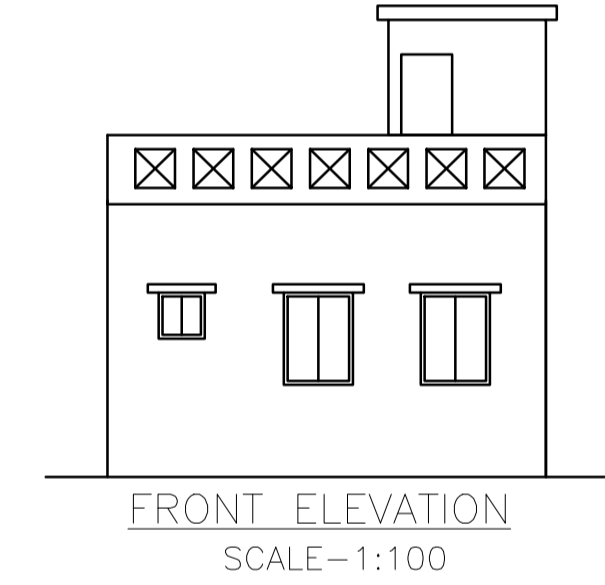
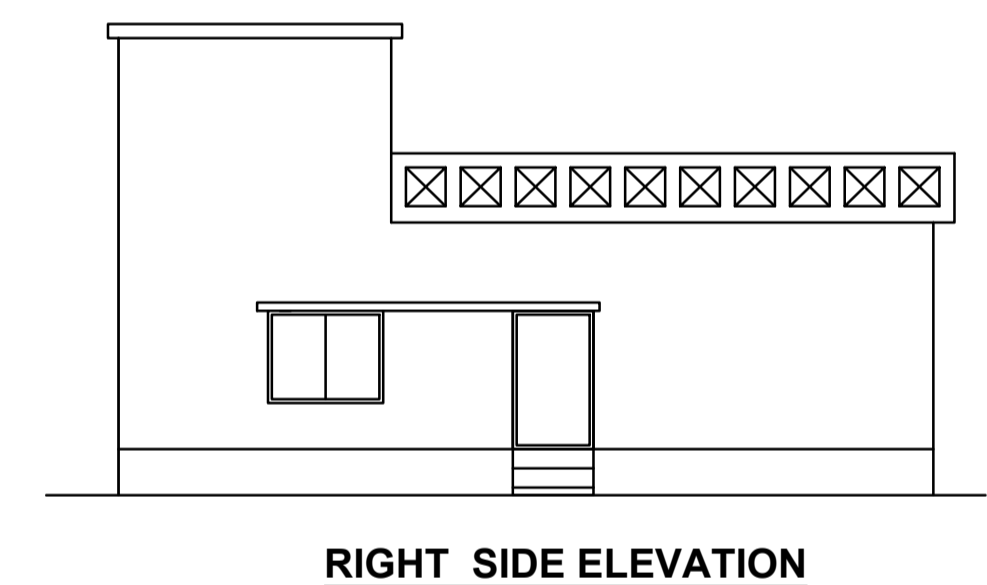
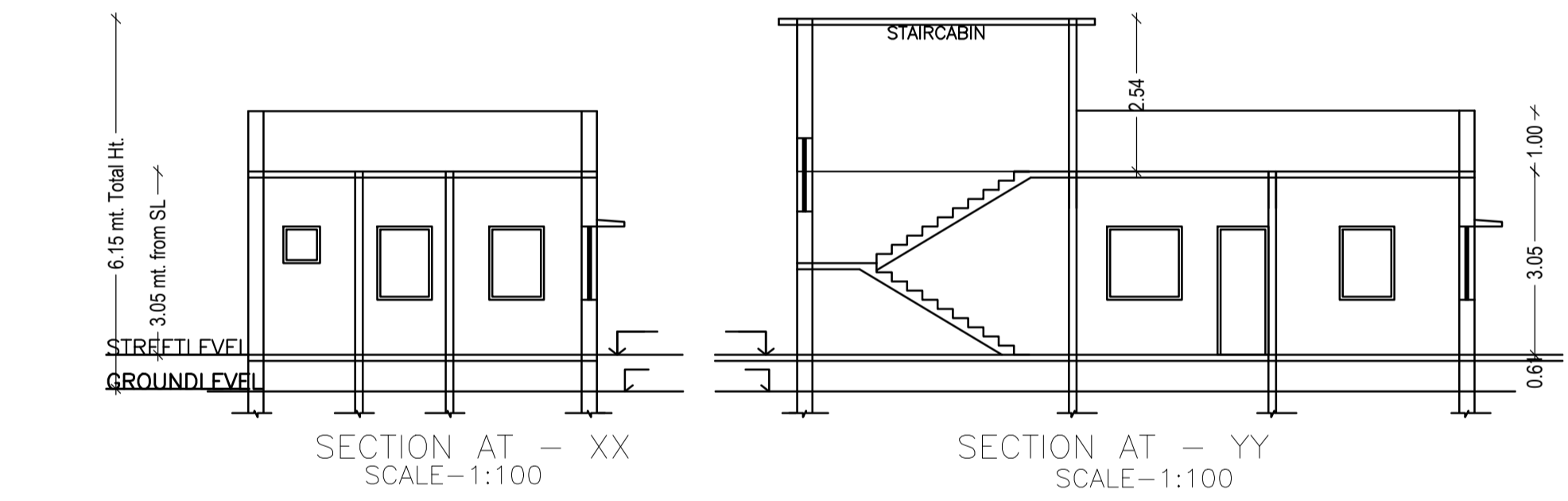

SITE PLAN

LTP NAME AND SIGNATURE	STRUCTURAL ENG'S NAME AND SIGNATURE	BUILDER NAME AND SIGNATURE
SHYAM DUTT SHUKLA PNPC/ENG/0004/2017		