

# Project Title :MRS ANITA DEVI JAISAWAL

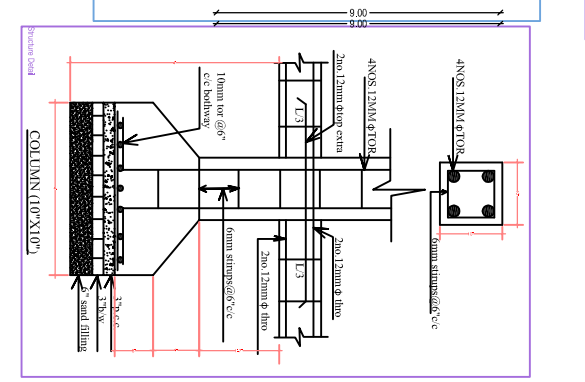
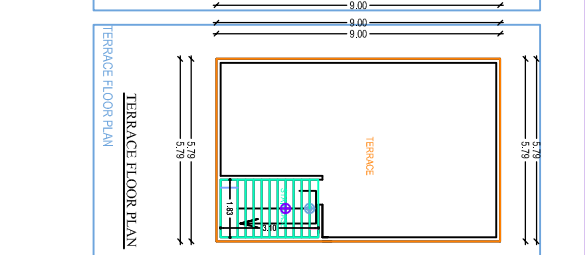
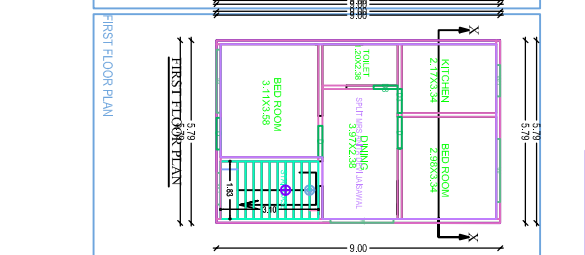
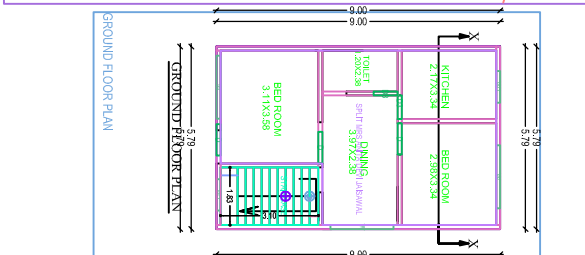
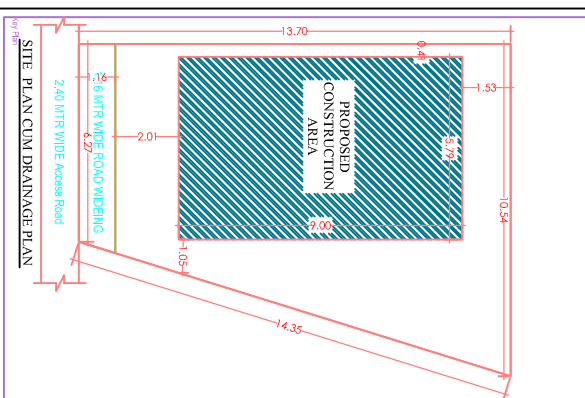
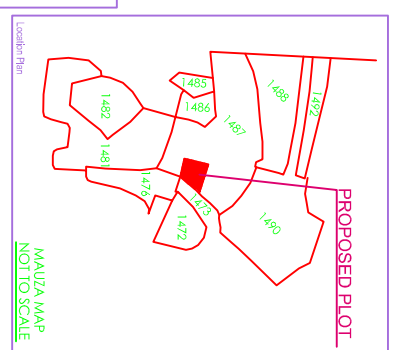
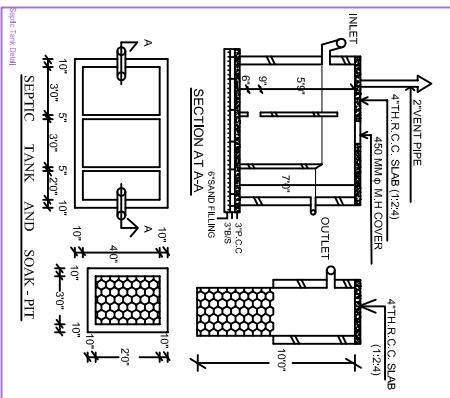
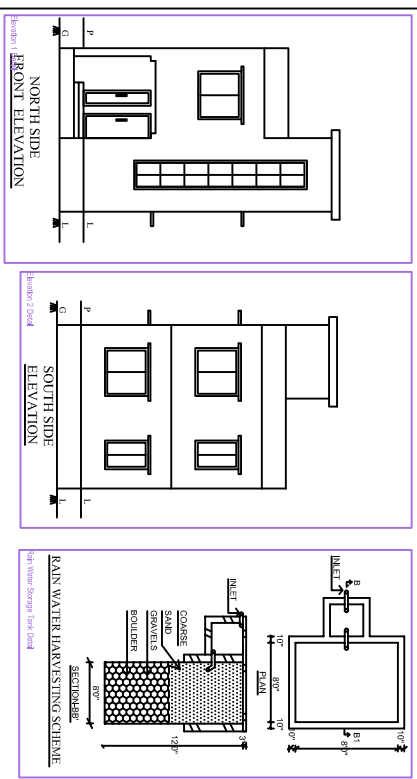
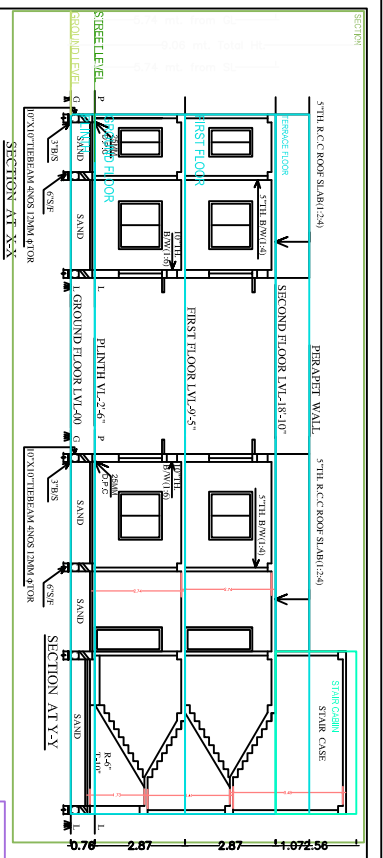

**PROPOSED RESIDENTIAL BUILDING PLAN FOR**  
**LAND OWNER**  
**MRS ANITA DEVI JAISAWAL**  
**W/O - MR PRADEEP JAISAWAL**

**DETAILS OF PLOT :-**  
 PLOT NO :- 1487  
 KHATA NO :- 567  
 MOUZA :- PAKUR  
 WARD NO :- 12  
 THANA NO :- 128  
 DISTRICT :- PAKUR, JHARKHAND

SIGNATURE OF OWNERS

SIGNATURE OF ENGINEER'S

Item Name	Quantity	Unit	Rate	Total
Plot Area	1	Sq. Mtr	104.28	104.28
Construction Area	1	Sq. Mtr	104.28	104.28
Site Area	1	Sq. Mtr	104.28	104.28
Overall Area	1	Sq. Mtr	104.28	104.28

Item Name	Quantity	Unit	Rate	Total
Plot Area	1	Sq. Mtr	104.28	104.28
Construction Area	1	Sq. Mtr	104.28	104.28
Site Area	1	Sq. Mtr	104.28	104.28
Overall Area	1	Sq. Mtr	104.28	104.28

Item Name	Quantity	Unit	Rate	Total
Plot Area	1	Sq. Mtr	104.28	104.28
Construction Area	1	Sq. Mtr	104.28	104.28
Site Area	1	Sq. Mtr	104.28	104.28
Overall Area	1	Sq. Mtr	104.28	104.28

Item Name	Quantity	Unit	Rate	Total
Plot Area	1	Sq. Mtr	104.28	104.28
Construction Area	1	Sq. Mtr	104.28	104.28
Site Area	1	Sq. Mtr	104.28	104.28
Overall Area	1	Sq. Mtr	104.28	104.28