

Proposal Basic Information	
Proposal File No.	PNPC/BP/0006/W10/2018
Owner Name	HARMEET KOUR
Khata No	1817
Plot No	619/2661
Village Name	Pakur
Use	Residential
SubUse	Residential Bldg/Apartment

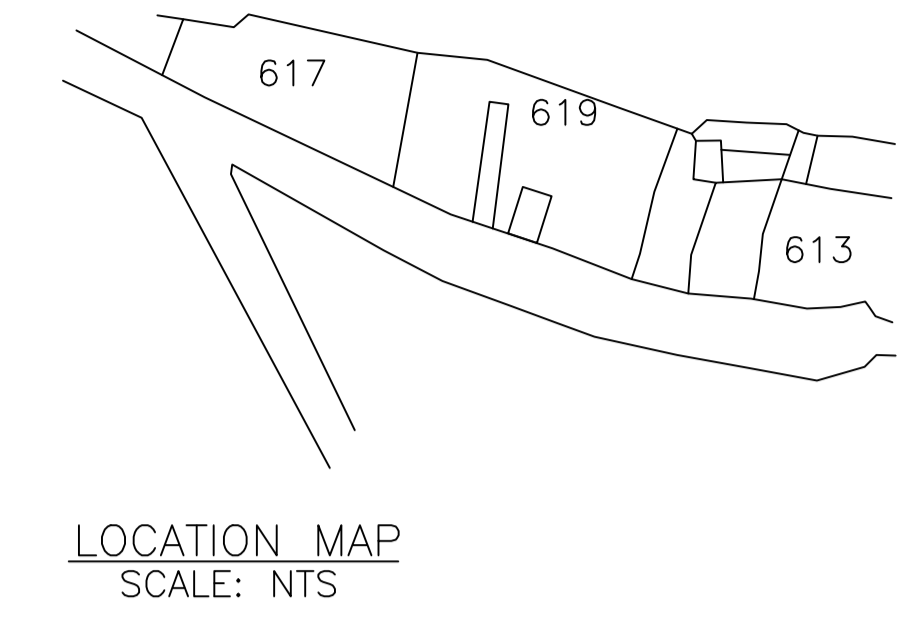
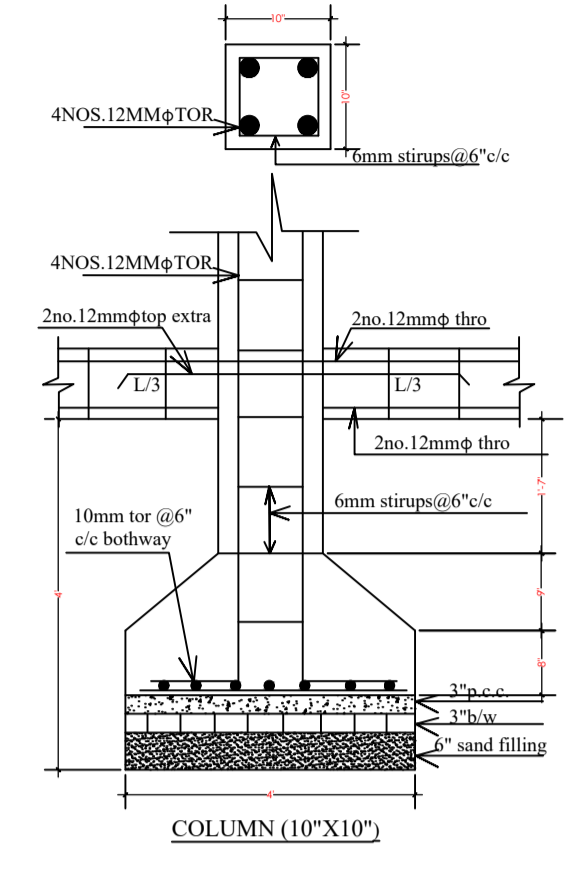
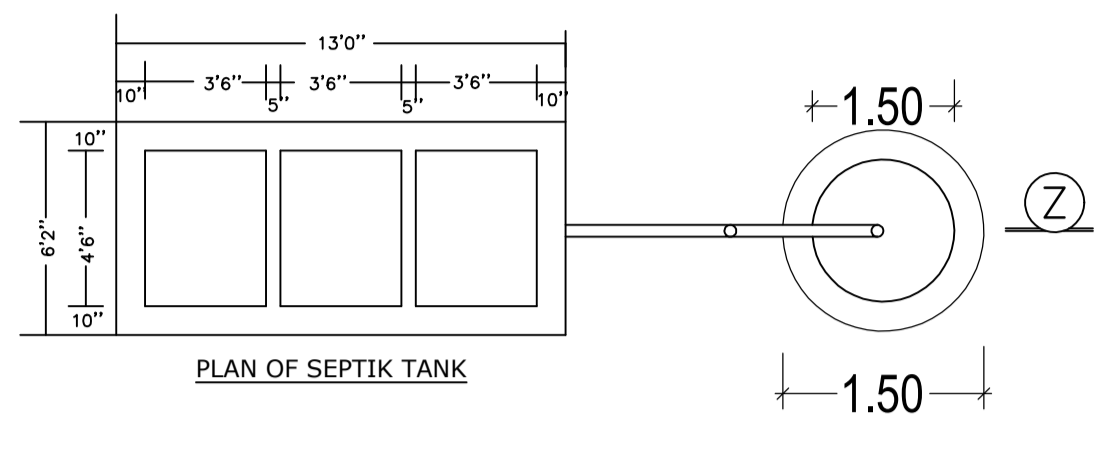
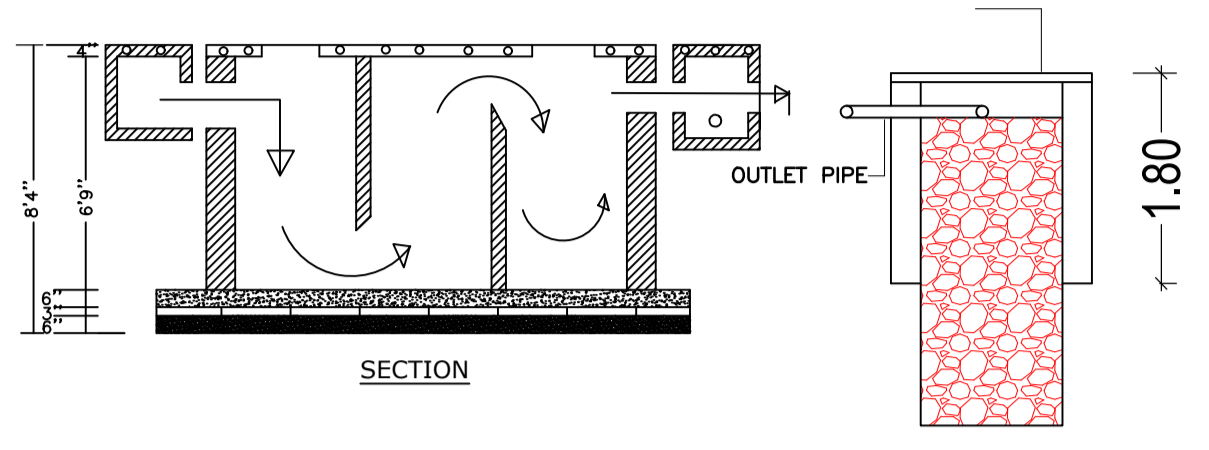

COLOR INDEX	
PLOT BOUNDARY	Black
ABUTTING ROAD	Green
PROPOSED CONSTRUCTION	Red
COMMON PLOT	Yellow
ROAD WIDENING AREA	Orange
EXISTING (To be retained)	Blue
EXISTING (To be demolished)	Light Blue

UnitBUA Table for Building :A (MRS HARMEET KOUR)

FLOOR	Name	UnitBUA Type	UnitBUA Area	Carpet Area	No. of Rooms	No. of Tenement
GROUND FLOOR PLAN	SPLIT MRS HARMEET KOUR	FLAT	56.62	55.58	3	1
FIRST FLOOR PLAN	SPLIT MRS HARMEET KOUR	FLAT	0.00	0.00	3	0
Total:	-	-	56.62	55.58	6	1

SCHEDULE OF DOOR:

BUILDING NAME	NAME	LENGTH	HEIGHT	NOS
A (MRS HARMEET KOUR)	D2	0.76	2.13	02
A (MRS HARMEET KOUR)	D1	0.90	2.13	04
A (MRS HARMEET KOUR)	D	1.05	2.13	01

SCHEDULE OF WINDOW/VENTILATION:

BUILDING NAME	NAME	LENGTH	HEIGHT	NOS
A (MRS HARMEET KOUR)	V	0.60	0.60	02
A (MRS HARMEET KOUR)	W1	2.00	2.50	02
A (MRS HARMEET KOUR)	W	2.50	2.50	02

FAR & Tenement Details (Table 4c-1)

Building	No. of Same Bldg	Total Built Up Area (Sq.mt.)	Proposed FAR Area (Sq.mt.) Resi.	Total FAR Area (Sq.mt.)	Total Consumed Additional FAR Area (Sq.mt.)	Tnmt (No.)
A (MRS HARMEET KOUR)	1	77.50	77.50	77.50	77.50	01
Grand Total :	1	77.50	77.50	77.50	77.50	01

Building USE/SUBUSE Details

Building Name	Building Use	Building SubUse	Building Structure
A (MRS HARMEET KOUR)	Residential	Residential Bldg/Apartment	Non-Highrise

Buildingwise Floor FAR Details

Floor Name	Building Name (MRS HARMEET KOUR)		Total	
	Proposed Built Up Area (Sq.mt.)	Proposed FAR Area (Sq.mt.)	Total Proposed Built Up Area (Sq.mt.)	Total FAR Area (Sq.mt.)
Ground Floor	38.75	38.75	38.75	38.75
First Floor	38.75	38.75	38.75	38.75
Terrace Floor	0.00	0.00	0.00	0.00
Total :	77.50	77.50	77.50	77.50

Building :A (MRS HARMEET KOUR)

Floor Name	Total Built Up Area (Sq.mt.)	Proposed FAR Area (Sq.mt.) Resi.	Total FAR Area (Sq.mt.)	Total Consumed Additional FAR Area (Sq.mt.)	Tnmt (No.)
Ground Floor	38.75	38.75	38.75	38.75	01
First Floor	38.75	38.75	38.75	38.75	00
Terrace Floor	0.00	0.00	0.00	0.00	00
Total :	77.50	77.50	77.50	77.50	01

AREA STATEMENT PAKUR NAGAR PARISHAD		VERSION NO.: 1.0.27
PROJECT DETAIL:		VERSION DATE: 18/05/2018
Region: JHARKHAND URBAN	Plot Use: Residential	
LOCAL BODIES: District: PAKUR	Plot SubUse: Residential Bldg/Apartment	
Authority: PAKUR NAGAR PARISHAD	PlotNearby/ReligiousStructure: NA	
Inward_No: PNP/CP/0006/W10/2018	Plot/SubPlot No: 619/2661	
Application Type: General Proposal	North: Plot No. - PRIVATE	
Project Type: Building Permission	South: Road Width - 4.85	
Nature of Development: New	East: Plot No. - PRIVATE	
Location of Development Area: Old Area	West: Plot No. - PRIVATE	
AREA DETAILS:		SQ.MT.
AREA OF PLOT (Minimum)	(A)	67.05
Deduction for NetPlot Area		
Surrender Free of Cost		2.81
Total		2.81
NET AREA OF PLOT(Gross Plot Area - Deduction from Gross Plot area)	(A-Deductions)	64.24
Deduction for Balance Plot Area(from Gross Plot Area)		
Surrender Free of Cost		2.81
Common Plot		7.01
Total		9.82
BALANCE AREA OF PLOT(Net Plot Area - Recreational/Amenity space)	(A-Deductions)	57.23
PLOT AREA FOR COVERAGE(Net Plot Area)	(A-Deductions)	64.24
Plot Area for FAR (Net Plot Area + RoadWidening Area)	(A-Deductions)	67.05
COVERAGE CHECK		
Permissible Coverage area (70.00 %)		44.97
Proposed Coverage Area (60.32 %)		38.75
Total Prop. Coverage Area (60.32 %)		38.75
Balance coverage area (9.68 %)		6.22
FAR CHECK		
Perm. FAR Area (1.80)		120.68
Total Perm. FAR area		120.68
Residential FAR		77.49
Proposed FAR Area		77.49
Total Proposed FAR Area		77.49
Consumed FAR (Factor)		1.16
Balance FAR Area		43.19
BUILT UP AREA CHECK		
Total Proposed BuiltUp Area		77.50
ARCHITECT (Regd)	SHYAM DUTT SHUKLA	
ENGINEER (Regd)		
SUPERVISOR (Regd)		
OWNER (Regd)	HARMEET KOUR	
DEVELOPMENT AUTHORITY		LOCAL BODY

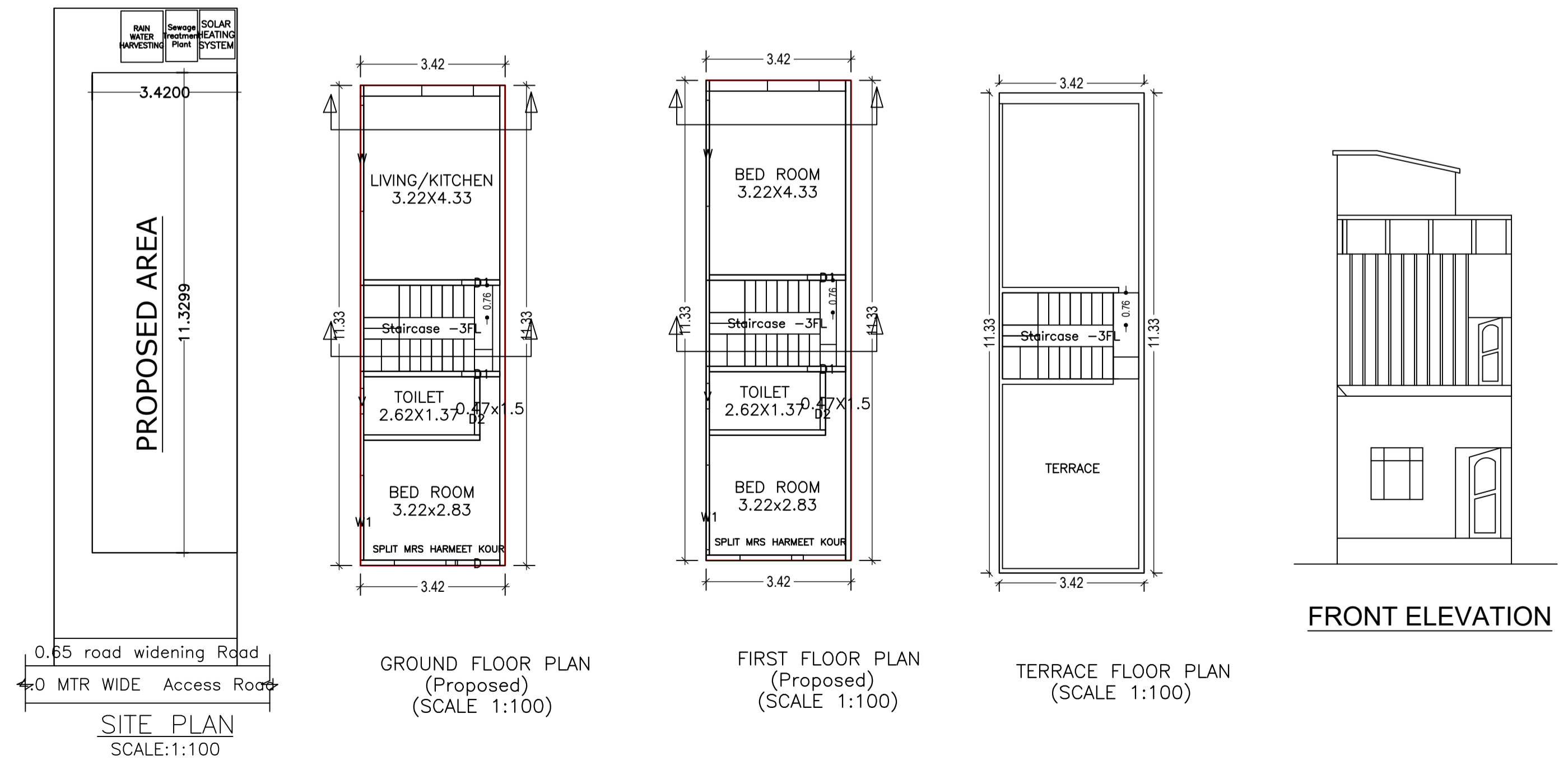
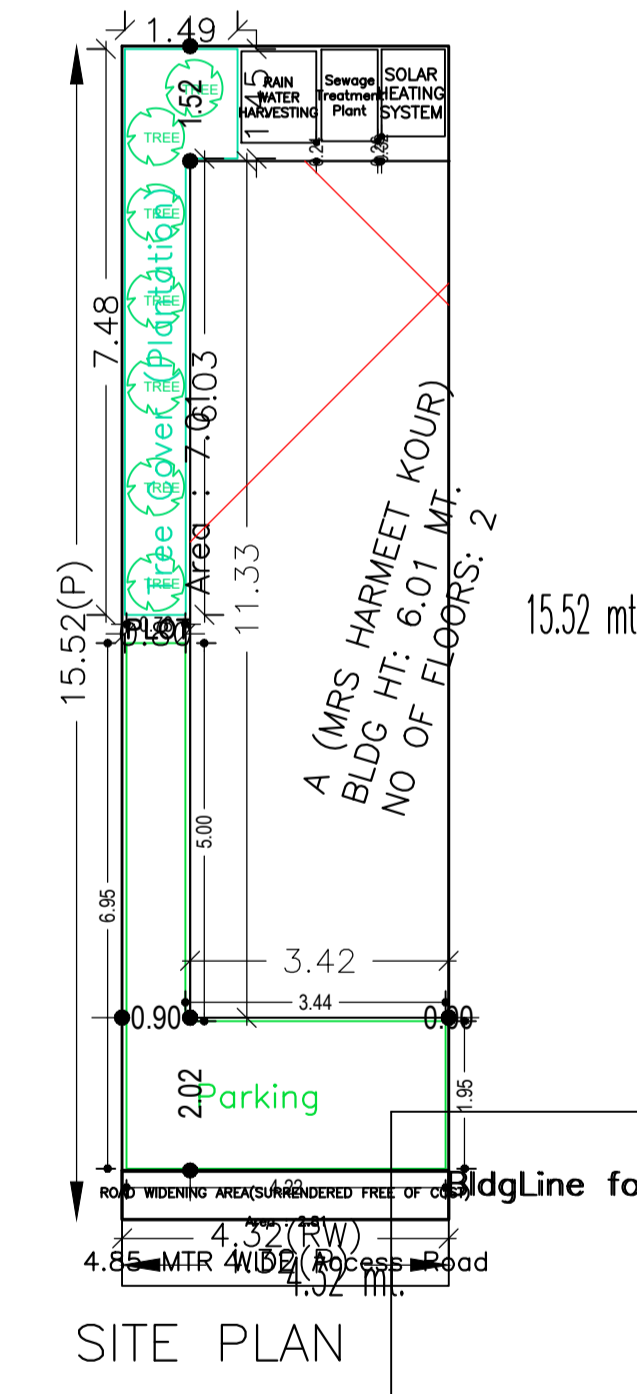
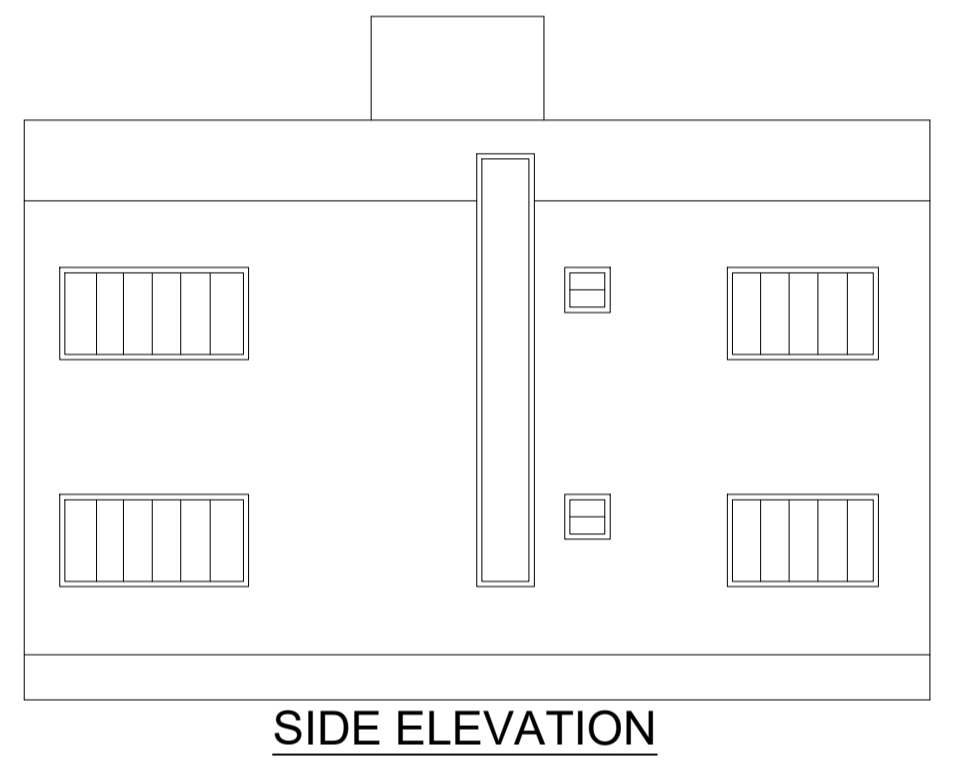
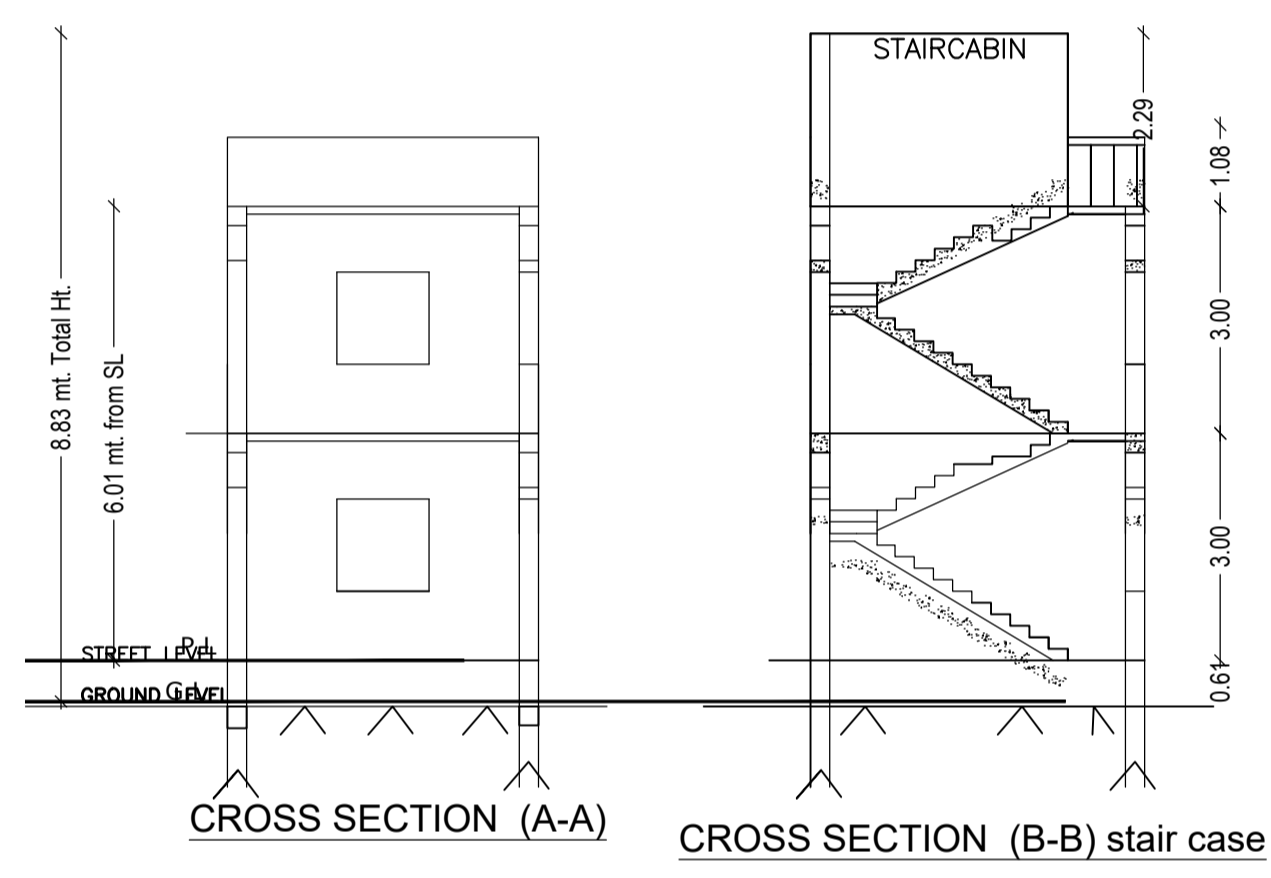

LTP NAME AND SIGNATURE	STRUCTURAL ENG'S NAME AND SIGNATURE	BUILDER NAME AND SIGNATURE
SHYAM DUTT SHUKLA PNPC/ENG/0004/2017		