

Proposal Basic Information	
Proposal File No.	PNPC/BP/0007/W10/2018
Owner Name	LUTFAL HAQUE
Khata No	532
Plot No	1909
Village Name	Pakur
Use	Residential
SubUse	Residential Bldg/Apartment

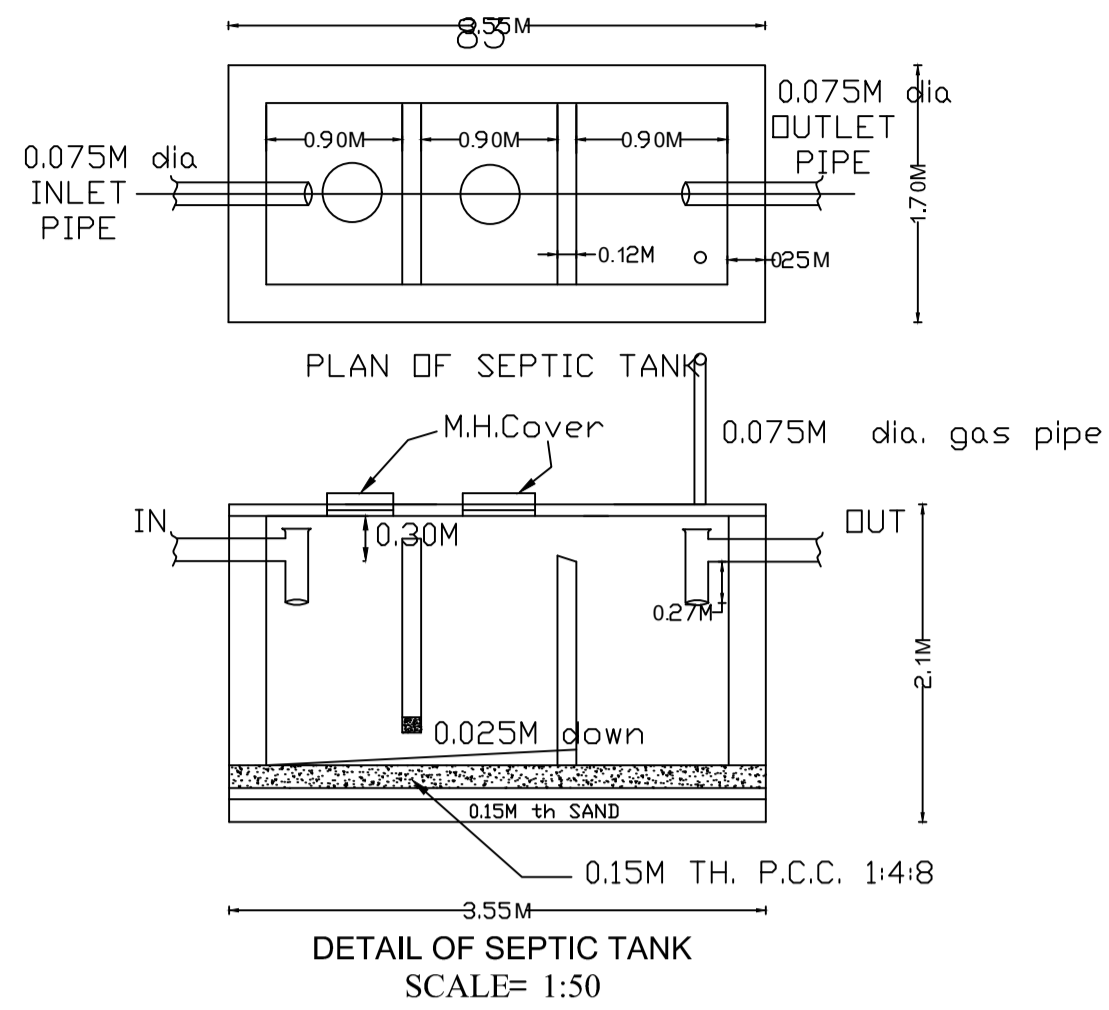

SCHEDULE OF DOOR:

BUILDING NAME	NAME	LENGTH	HEIGHT	NOS
A (LUTFAL HAQUE)	D1	0.76	2.13	03
A (LUTFAL HAQUE)	D	0.90	2.13	04

SCHEDULE OF WINDOW/VENTILATION:

BUILDING NAME	NAME	LENGTH	HEIGHT	NOS
A (LUTFAL HAQUE)	V	0.76	0.76	03
A (LUTFAL HAQUE)	W1	1.20	2.50	08
A (LUTFAL HAQUE)	W	2.00	2.50	02

COLOR INDEX

PLOT BOUNDARY	[Red Line]
ABUTTING ROAD	[Green Line]
PROPOSED CONSTRUCTION	[Yellow Line]
COMMON PLOT	[Blue Line]
ROAD WIDENING AREA	[Orange Line]
EXISTING (To be retained)	[Green Line]
EXISTING (To be demolished)	[Red Line]

FAR & Tenement Details (Table 4c-1)

Building	No. of Same Bldg	Total Built Up Area (Sq.mt.)	Proposed FAR Area (Sq.mt.) Resi.	Total FAR Area (Sq.mt.)	Total Consumed Additional FAR Area (Sq.mt.)	Tnmt (No.)
A (LUTFAL HAQUE)	1	70.92	70.92	70.92	70.92	01
Grand Total :	1	70.92	70.92	70.92	70.92	01

Buildingwise Floor FAR Details

Floor Name	Building Name A (LUTFAL HAQUE)		Total	
	Proposed Built Up Area (Sq.mt.)	Proposed FAR Area (Sq.mt.)	Total Proposed Built Up Area (Sq.mt.)	Total FAR Area (Sq.mt.)
Ground Floor	23.64	23.64	23.64	23.64
First Floor	23.64	23.64	23.64	23.64
Second Floor	23.64	23.64	23.64	23.64
Terrace Floor	0.00	0.00	0.00	0.00
Total :	70.92	70.92	70.92	70.92

Building USE/SUBUSE Details

Building Name	Building Use	Building SubUse	Building Structure
A (LUTFAL HAQUE)	Residential		Non-Highrise

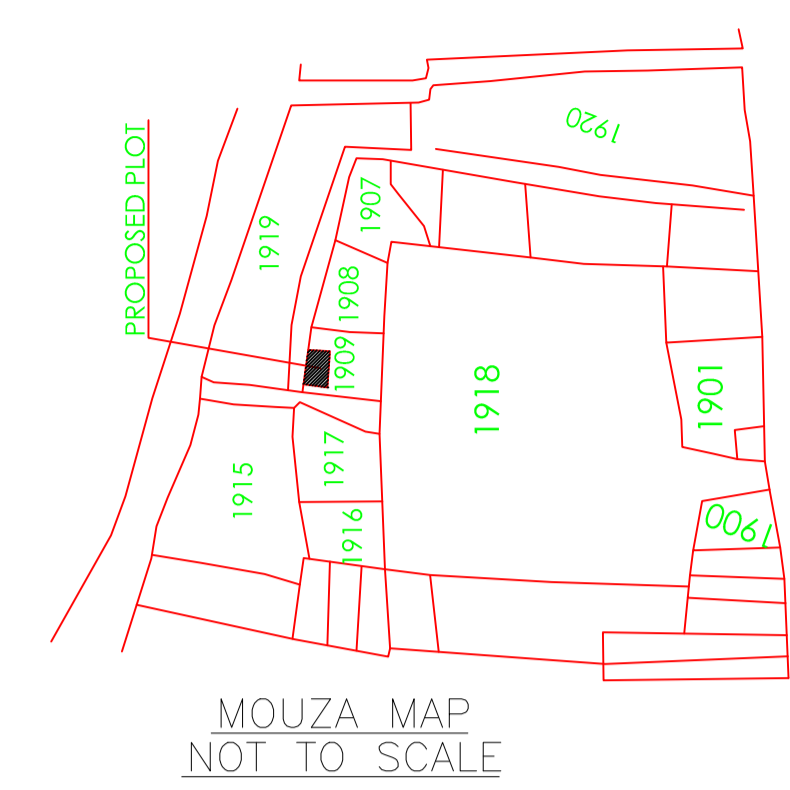

UnitBUA Table for Building :A (LUTFAL HAQUE)

FLOOR	Name	UnitBUA Type	UnitBUA Area	Carpet Area	No. of Rooms	No. of Tenement
GROUND FLOOR PLAN	SPLIT LUTFAL HAQUE	FLAT	38.93	37.48	3	1
FIRST FLOOR PLAN	SPLIT LUTFAL HAQUE	FLAT	0.00	0.00	2	0
SECOND FLOOR PLAN	SPLIT LUTFAL HAQUE	FLAT	0.00	0.00	2	0
Total :	-	-	38.93	37.48	7	1

Building :A (LUTFAL HAQUE)

Floor Name	Total Built Up Area (Sq.mt.)	Proposed FAR Area (Sq.mt.) Resi.	Total FAR Area (Sq.mt.)	Total Consumed Additional FAR Area (Sq.mt.)	Tnmt (No.)
Ground Floor	23.64	23.64	23.64	23.64	01
First Floor	23.64	23.64	23.64	23.64	00
Second Floor	23.64	23.64	23.64	23.64	00
Terrace Floor	0.00	0.00	0.00	0.00	00
Total :	70.92	70.92	70.92	70.92	01
Total Number of Same Buildings :	1				
Total :	70.92	70.92	70.92	70.92	01

DETAILS OF RAIN WATER HARVESTING STRUCTURES

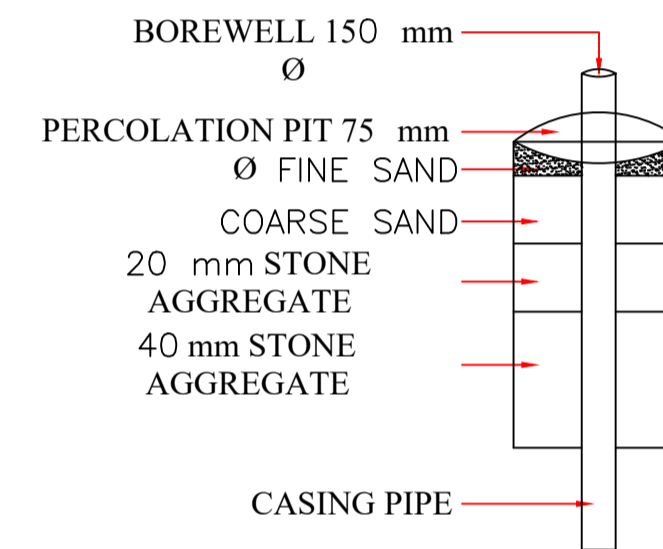

CROSS SECTION OF RAIN WATER 1.00M DIA PERCOLATION WELL FOR RECHARGING BORE WELL

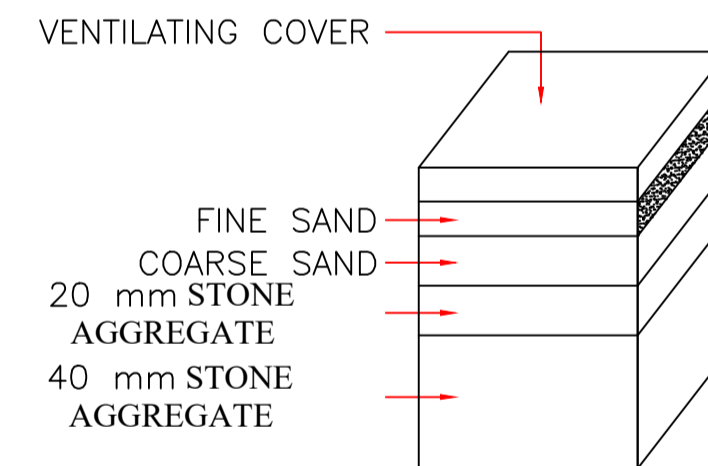

CROSS SECTION OF PERCOLATION PIT/TRENCH OF RAIN WATER

SCALE = N.T.S.

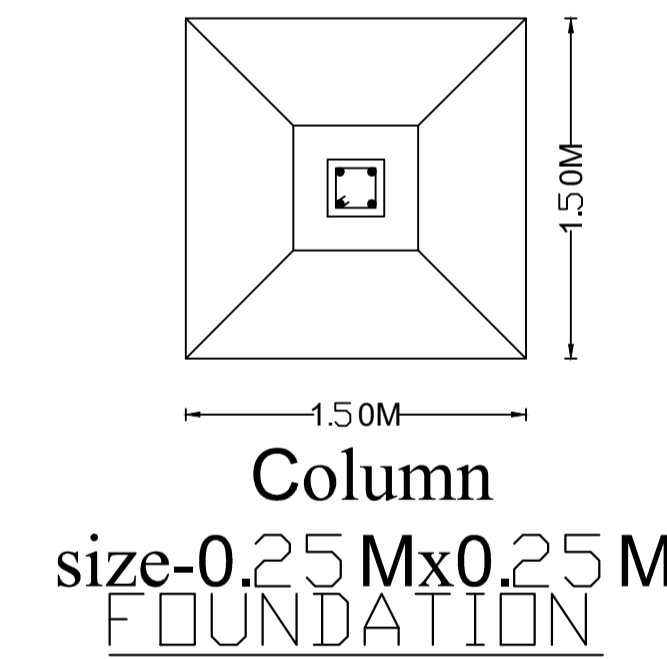
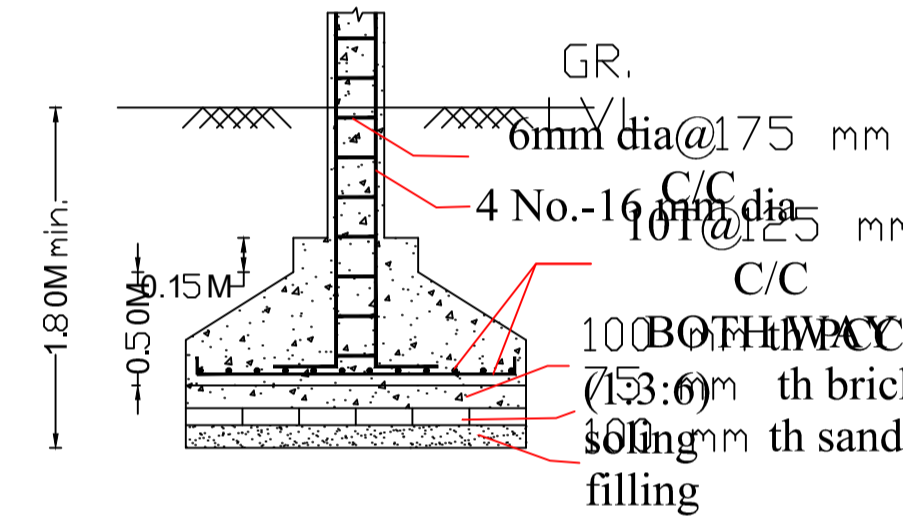

SCALE = 1:50

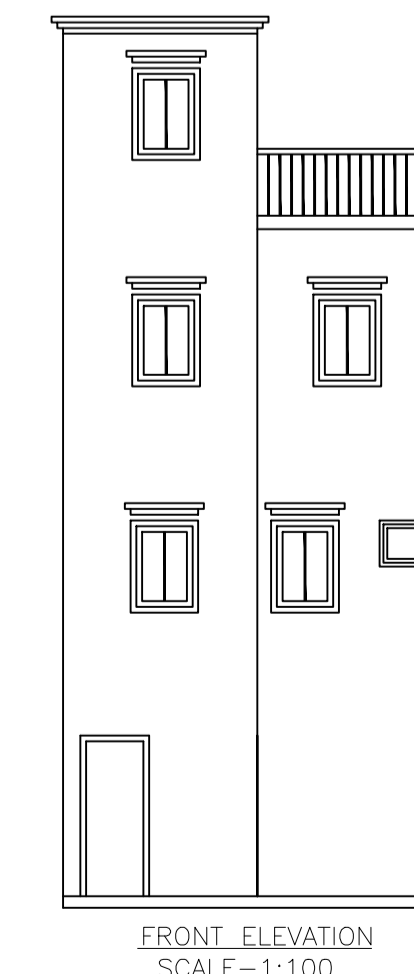
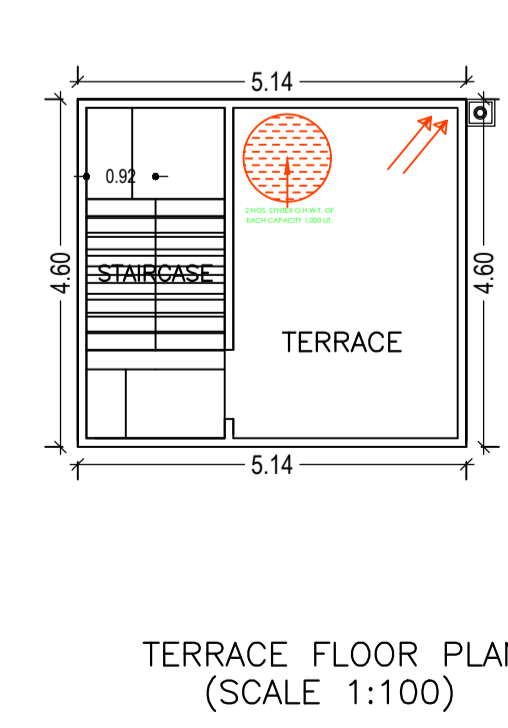
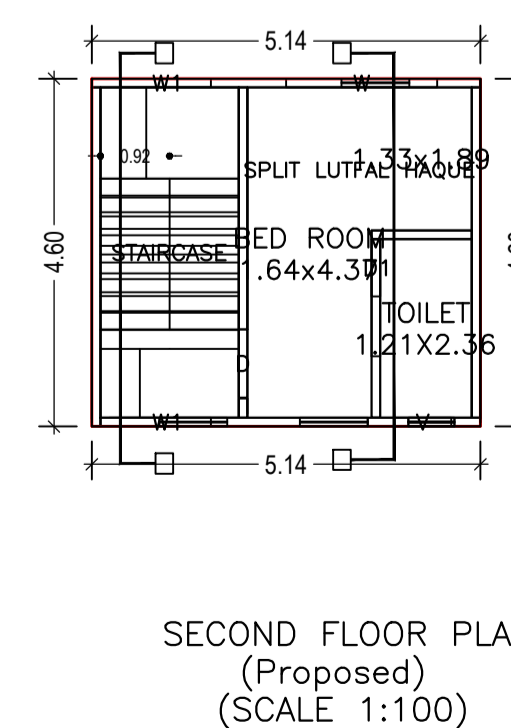
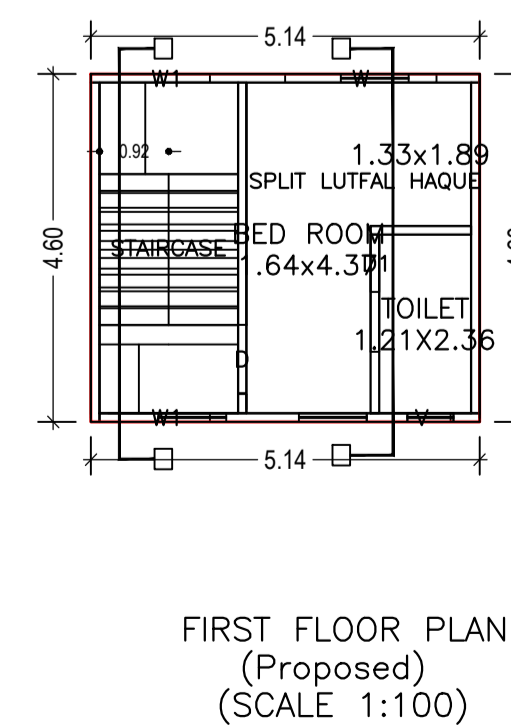
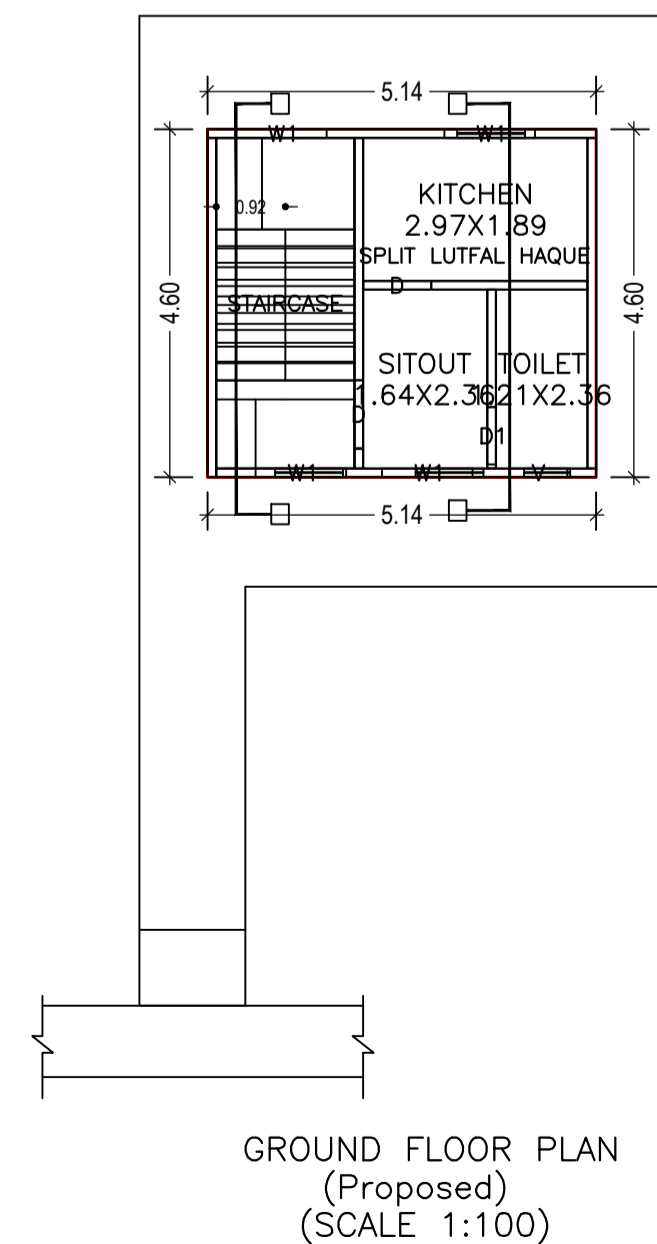
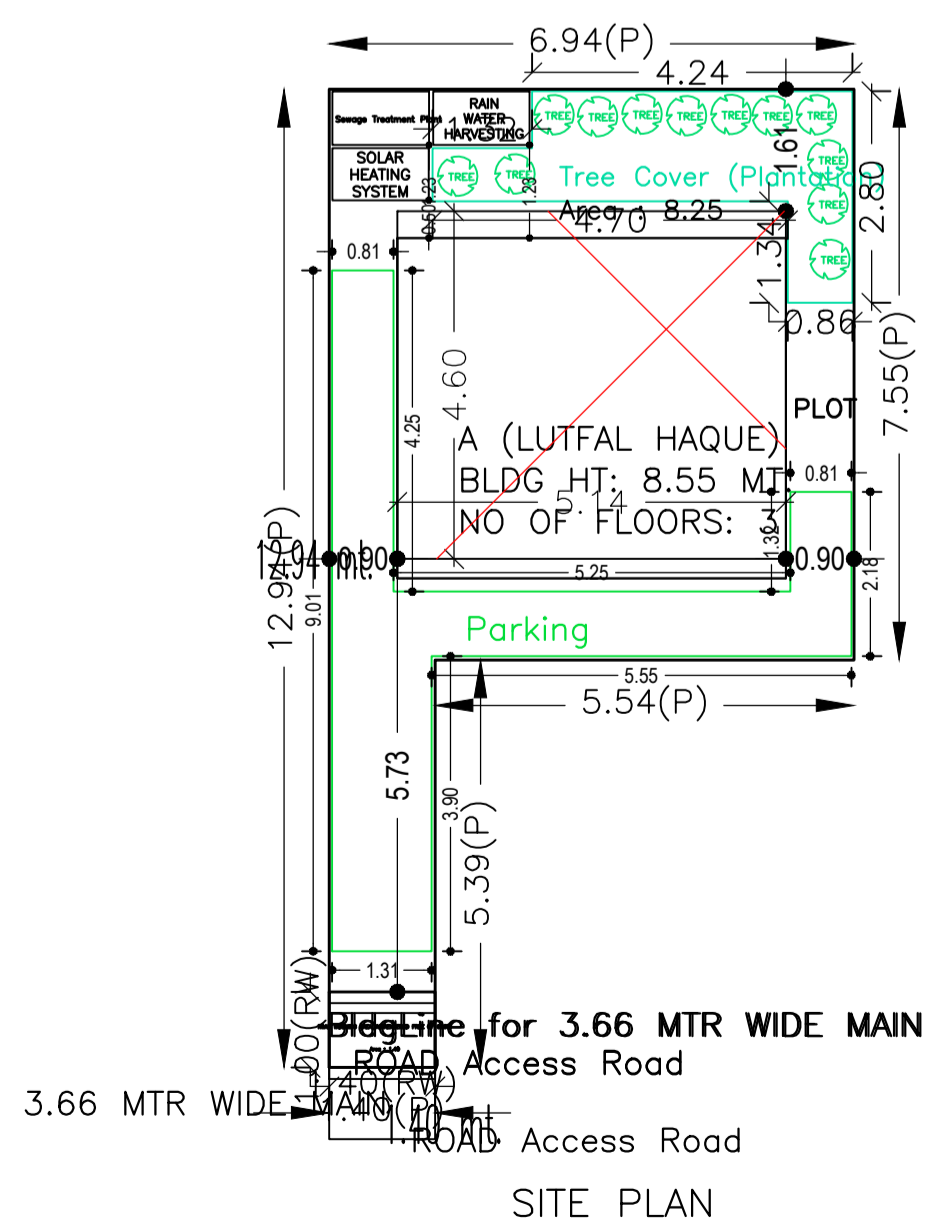
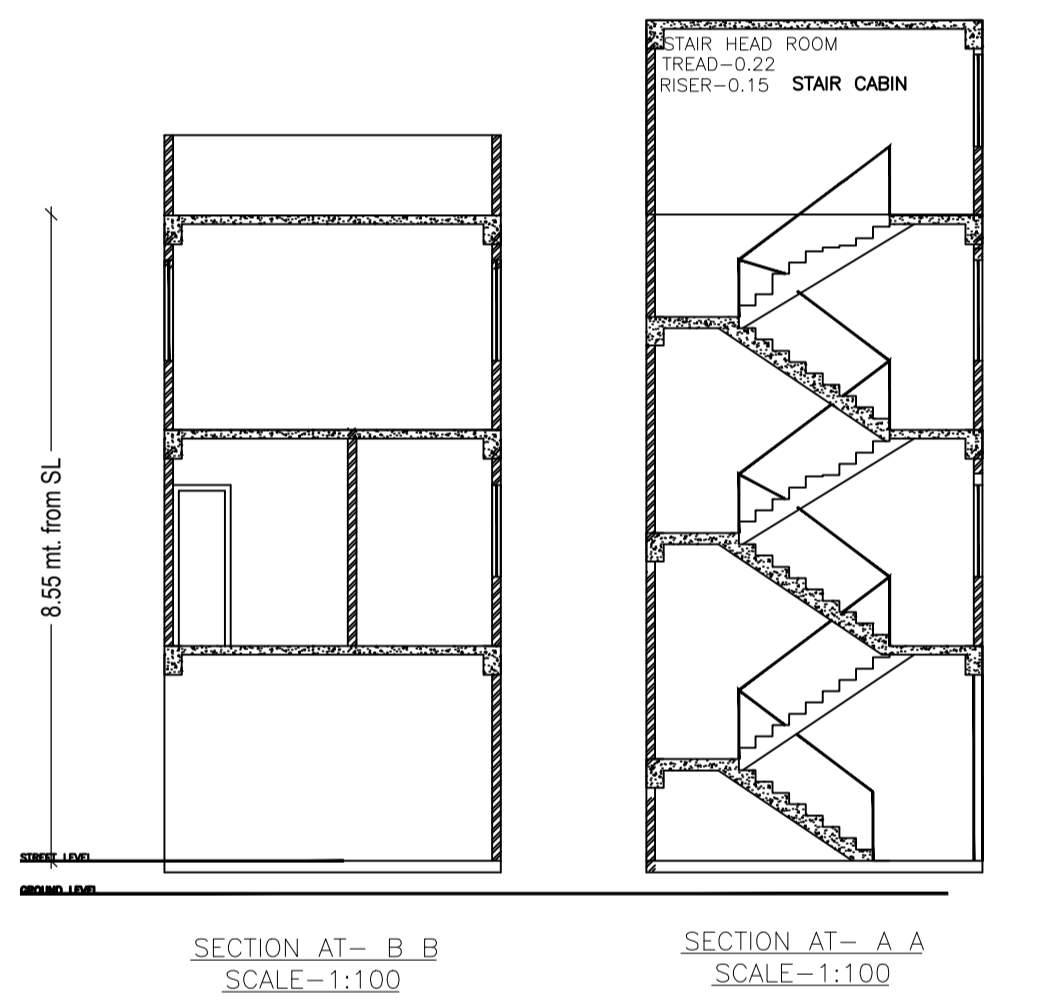

AREA STATEMENT PAKUR NAGAR PARISHAD		VERSION NO. : 1.0.27	VERSION DATE: 18/09/2018
PROJECT DETAIL:			
Region: JHARKHAND URBAN LOCAL BODIES	Plot Use: Residential		
District: PAKUR	Plot SubUse: Residential Bldg/Apartment		
Authority: PAKUR NAGAR PARISHAD	Plot/Nearby/Religious Structure: NA		
Inward No: PNP/0007/W10/2018	Plot/SubPlot No: 1909		
Application Type: General Proposal	North: Plot No. - PRIVATE		
Project Type: Building Permission	South: Plot No. - PRIVATE		
Nature of Development: New	East: Plot No. - PRIVATE		
Location of Development Area: Old Area	West: Road Width - 3.66		
AREA DETAILS:			
AREA OF PLOT (Minimum)	(A)		SQ.MT. 59.94
Deduction for NetPlot Area			
Surrender Free of Cost			1.40
Total			1.40
NET AREA OF PLOT(Gross Plot Area - Deduction from Gross Plot area)	(A-Deductions)		58.54
Deduction for Balance Plot Area(from Gross Plot Area)			
Surrender Free of Cost			1.40
Common Plot			8.25
Total			9.65
BALANCE AREA OF PLOT(Net Plot Area - Recreational/Amenity space)	(A-Deductions)		50.30
PLOT AREA FOR COVERAGE(Net Plot Area)	(A-Deductions)		58.54
Plot Area for FAR (Net Plot Area + RoadWidening Area)	(A-Deductions)		59.94
COVERAGE CHECK			
Permissible Coverage area (70.00 %)			40.98
Proposed Coverage Area (40.38 %)			23.64
Total Prop. Coverage Area (40.38 %)			23.64
Balance coverage area (29.62 %)			17.34
FAR CHECK			
Perm. FAR Area (1.50)			89.91
Total Perm. FAR area			89.91
Residential FAR			70.93
Proposed FAR Area			70.93
Total Proposed FAR Area			70.93
Consumed FAR (Factor)			1.18
Balance FAR Area			18.98
BUILT UP AREA CHECK			
Total Proposed BuiltUp Area			70.92
ARCHITECT (Regd) SHYAM DUTT SHUKLA			
ENGINEER (Regd)			
SUPERVISOR (Regd)			
OWNER (Regd) LUTFAL HAQUE			
DEVELOPMENT AUTHORITY LOCAL BODY			

LTP NAME AND SIGNATURE	STRUCTURAL ENG'S NAME AND SIGNATURE	BUILDER NAME AND SIGNATURE
SHYAM DUTT SHUKLA PNPC/ENG/0004/2017		