

UnitBUA Table for Building :A (SHRIPAT KUMAR)

FLOOR	Name	UnitBUA Type	UnitBUA Area	Carpet Area	No. of Rooms	No. of Tenement
GROUND FLOOR	SPLIT A	FLAT	66.68	66.60	7	1
Total:	-	-	66.68	66.60	7	1

**COLOR INDEX**

PLOT BOUNDARY	[Red Line]
ABUTTING ROAD	[Green Line]
PROPOSED CONSTRUCTION	[Yellow Line]
COMMON PLOT	[Blue Line]
ROAD WIDENING AREA	[Orange Line]
EXISTING (To be retained)	[Grey Line]
EXISTING (To be demolished)	[Black Line]

Building :A (SHRIPAT KUMAR)

Floor Name	Total Built Up Area (Sq.mt.)	Proposed FAR Area (Sq.mt.) Resi.	Total FAR Area (Sq.mt.)	Total Consumed Additional FAR Area (Sq.mt.)	Tnmt (No.)
Ground Floor	86.21	86.21	86.21	86.21	01
Terrace Floor	0.00	0.00	0.00	0.00	00
Total:	86.21	86.21	86.21	86.21	01
Total Number of Same Buildings :	1				
Total :	86.21	86.21	86.21	86.21	01

**Proposal Basic Information**

Proposal File No.	PNPC/BP/0022/W09/2019
Owner Name	SHRIPAT KUMAR
Khata No	58
Plot No	1959
Village Name	Pakur
Use	Residential
SubUse	Bungalow/ Dwelling / Non Apartment

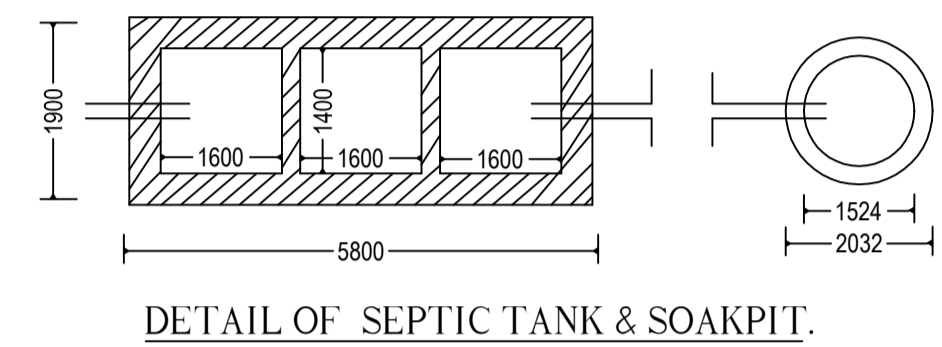
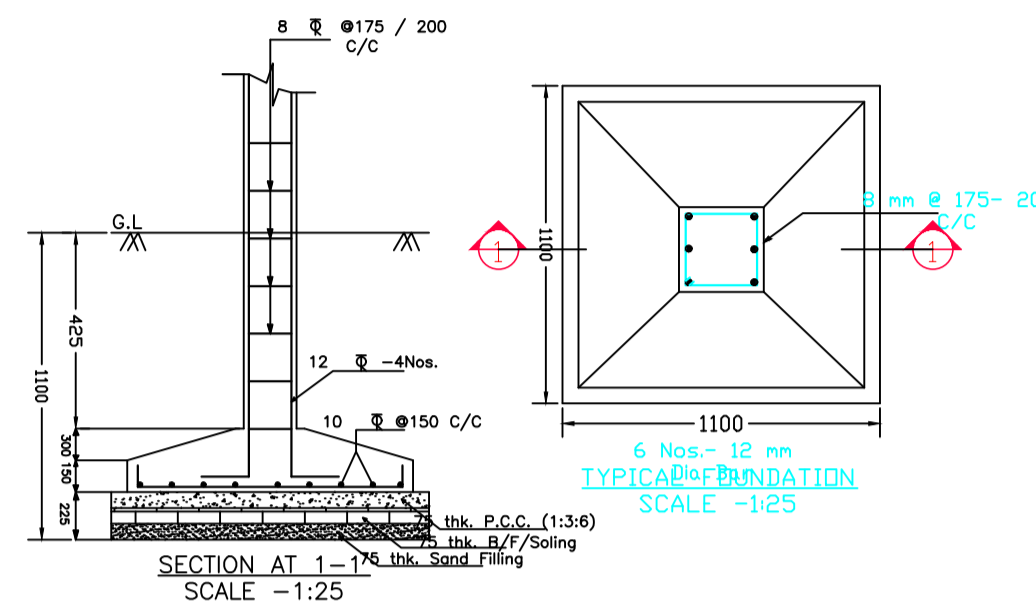
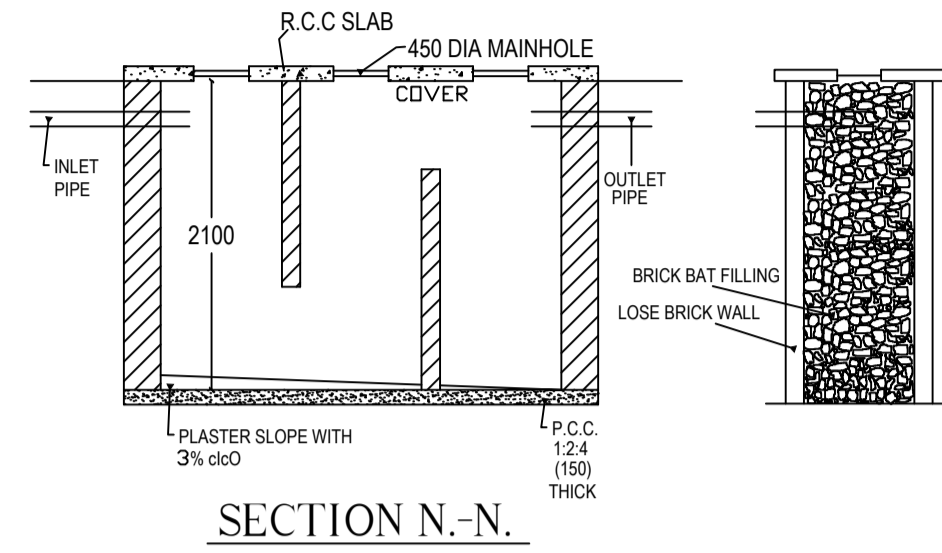
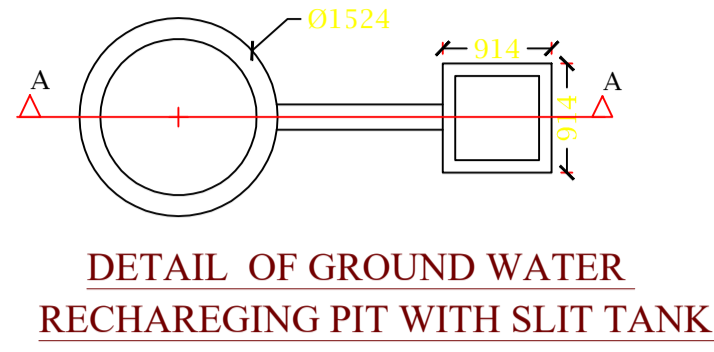

SCHEDULE OF DOOR:

BUILDING NAME	NAME	LENGTH	HEIGHT	NOS
A (SHRIPAT KUMAR)	D3	0.75	2.13	03
A (SHRIPAT KUMAR)	D2	0.91	2.13	04
A (SHRIPAT KUMAR)	D0	0.95	2.13	01

SCHEDULE OF WINDOW/VENTILATION:

BUILDING NAME	NAME	LENGTH	HEIGHT	NOS
A (SHRIPAT KUMAR)	V	0.60	2.70	02
A (SHRIPAT KUMAR)	W	1.50	2.70	05
A (SHRIPAT KUMAR)	W0	3.01	2.70	01

FAR & Tenement Details (Table 4c-1)

Building	No. of Same Bldg	Total Built Up Area (Sq.mt.)	Proposed FAR Area (Sq.mt.) Resi.	Total FAR Area (Sq.mt.)	Total Consumed Additional FAR Area (Sq.mt.)	Tnmt (No.)
A (SHRIPAT KUMAR)	1	86.21	86.21	86.21	86.21	01
Grand Total :	1	86.21	86.21	86.21	86.21	01

Buildingwise Floor FAR Details

Floor Name	Building Name		Total	
	Proposed Built Up Area (Sq.mt.)	Proposed FAR Area (Sq.mt.)	Total Proposed Built Up Area (Sq.mt.)	Total FAR Area (Sq.mt.)
Ground Floor	86.21	86.21	86.21	86.21
Terrace Floor	0.00	0.00	0.00	0.00
Total :	86.21	86.21	86.21	86.21

**AREA STATEMENT PAKUR NAGAR PARISHAD**

VERSION NO.: 1.0/41  
VERSION DATE: 29/04/2019

**PROJECT DETAIL:**

Region: JHARKHAND URBAN LOCAL BODIES	Plot Use: Residential
District: PAKUR	Plot SubUse: Bungalow/ Dwelling / Non Apartment
Authority: PAKUR NAGAR PARISHAD	PlotNearby/ReligiousStructure: NA
Inward No: PNP/0022/W09/2019	Plot/SubPlot No: 1959
Application Type: General Proposal	North -
Project Type: Building Permission	South -
Nature of Development: New	East: Road Width - 3.66
Location of Development Area: Old Area	West -

**AREA DETAILS:**

AREA OF PLOT (Minimum)	(A)	SQ.MT.	167.47
Deduction for NetPlot Area			
Surrender Free of Cost			7.79
Total			7.79
NET AREA OF PLOT(Gross Plot Area - Deduction from Gross Plot area)	(A-Deductions)		159.68
Deduction for Balance Plot Area(from Gross Plot Area)			
Surrender Free of Cost			7.79
Common Plot			26.96
Total			34.75
BALANCE AREA OF PLOT(Net Plot Area - Recreational/Armenity space)	(A-Deductions)		132.72
PLOT AREA FOR COVERAGE(Net Plot Area)	(A-Deductions)		159.68
Plot Area for FAR (Net Plot Area + Road/Widening Area)	(A-Deductions)		167.47

**COVERAGE CHECK**

Permissible Coverage area ( 70.00 % )	111.78
Proposed Coverage Area ( 53.99 % )	86.21
Total Prop. Coverage Area ( 53.99 % )	86.21
Balance coverage area ( 16.01 % )	25.57

**FAR CHECK**

Perm. FAR Area ( 1.50 )	251.21
Total Perm. FAR area	251.21
Residential FAR	86.21
Proposed FAR Area	86.21
Total Proposed FAR Area	86.21
Consumed FAR (Factor)	0.51
Balance FAR Area	165.00

**BUILT UP AREA CHECK**

Total Proposed BuiltUp Area	86.21
-----------------------------	-------

**ARCHITECT (Regd)** SHYAM DUTT SHUKLA  
**ENGINEER (Regd)**  
**SUPERVISOR (Regd)**  
**OWNER (Regd)** SHRIPAT KUMAR

**DEVELOPMENT AUTHORITY** LOCAL BODY

**Building USE/SUBUSE Details**

Building Name	Building Use	Building SubUse	Building Structure
A (SHRIPAT KUMAR)	Residential	Bungalow/ Dwelling / Non Apartment	Non-Highrise

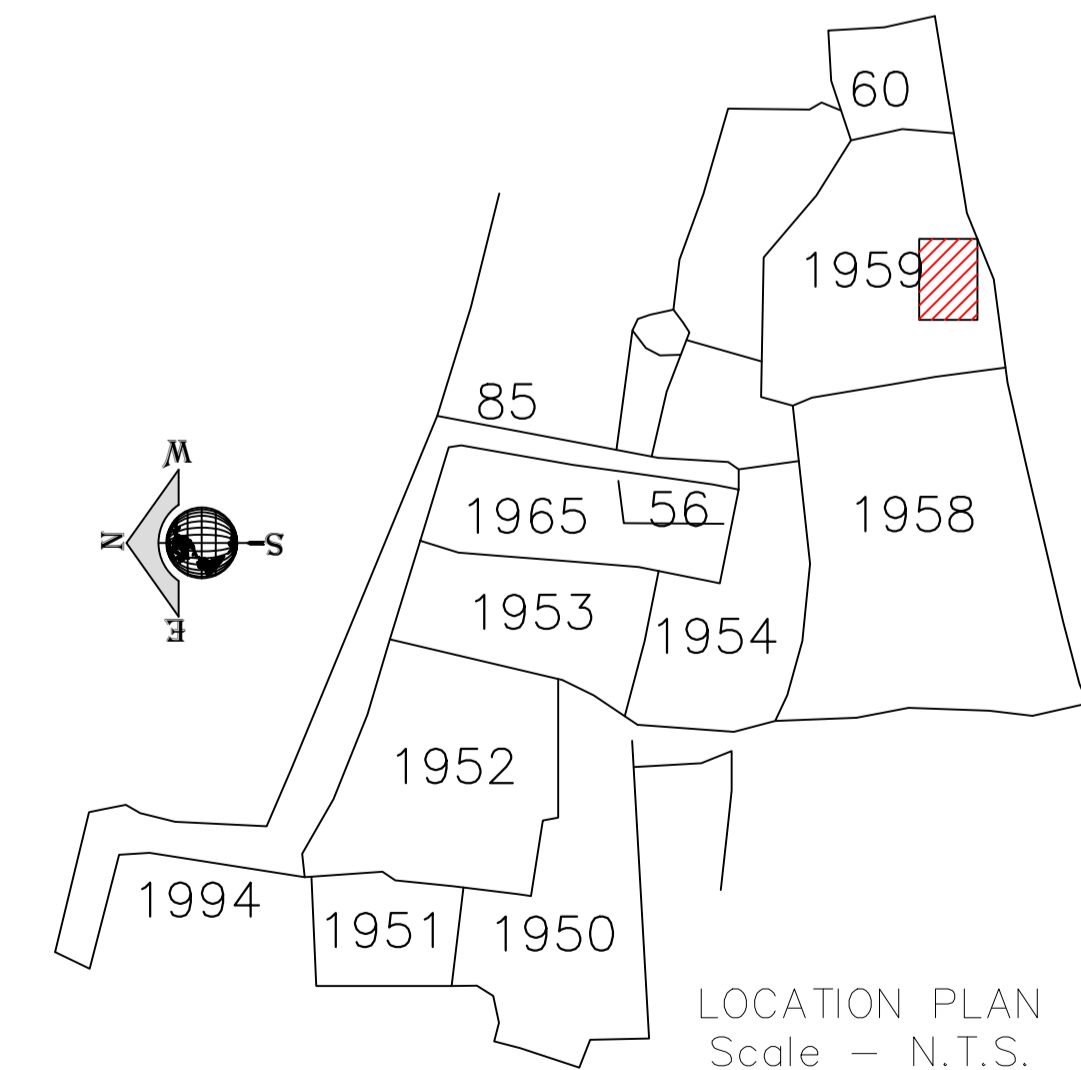

LTP NAME AND SIGNATURE	STRUCTURAL ENG'S NAME AND SIGNATURE	BUILDER NAME AND SIGNATURE	DIGITAL SIGNATURE
SHYAM DUTT SHUKLA PNPC/ENG/0004/2017			

