

Proposal Basic Information	
Proposal File No.	PNPC/BP/0005/W03/2021
Owner Name	AJIT KUMAR JHA & SMT SHARDA DEVI
Khata No	602
Plot No	1222
Village Name	Pakur
Use	Residential
SubUse	Bungalow/ Dwelling / Non Apartment

Building USE/SUBUSE Details

Building Name	Building Use	Building SubUse	Building Structure
A (BUILDING G1)	Residential	Bungalow/ Dwelling / Non Apartment	Non-Highrise

AREA STATEMENT PAKUR NAGAR PARISHAD		VERSION NO.: 1.0.54
PROJECT DETAIL:		VERSION DATE: 16/10/2020
Region: JHARKHAND URBAN LOCAL BODIES	Plot Use: Residential	
District: PAKUR	Plot SubUse: Bungalow/ Dwelling / Non Apartment	
Authority: PAKUR NAGAR PARISHAD	PlotNearbyReligiousStructure: NA	
Inward_No: PNP/0005/W03/2021	Plot/SubPlot No: 1222	
Application Type: General Proposal	North: -	
Project Type: Building Permission	South: -	
Nature of Development: New	East: -	
Location of Development Area: New Area	West: -	
AREA DETAILS: SQ.MT.		
AREA OF PLOT (Minimum)	(A)	133.12
Deduction for NetPlot Area		
Surrender Free of Cost		3.84
Total		3.84
NET AREA OF PLOT(Gross Plot Area - Deduction from Gross Plot area)	(A-Deductions)	129.28
Deduction for Balance Plot Area(from Gross Plot Area)		
Surrender Free of Cost		3.84
Common Plot		15.60
Total		19.44
BALANCE AREA OF PLOT(Net Plot Area - Recreational/Amenity space)	(A-Deductions)	113.68
PLOT AREA FOR COVERAGE(Net Plot Area)	(A-Deductions)	129.28
Plot Area for FAR (Net Plot Area + RoadWidening Area)	(A-Deductions)	133.12
COVERAGE CHECK		
Permissible Coverage area (70.00 %)		90.50
Proposed Coverage Area (56.16 %)		72.60
Total Prop. Coverage Area (56.16 %)		72.60
Balance coverage area (13.85 %)		17.90
FAR CHECK		
Perm. FAR Area (1.20)		159.74
Total Perm. FAR area		159.74
Residential FAR		145.20
Proposed FAR Area		145.20
Total Proposed FAR Area		145.20
Consumed FAR (Factor)		1.09
Balance FAR Area		14.54
BUILT UP AREA CHECK		
Total Proposed BuiltUp Area		145.20
ARCHITECT (Regd)	Navin Kumar Mandal	
ENGINEER (Regd)		
SUPERVISOR (Regd)		
OWNER (Regd)	AJIT KUMAR JHA & SMT SHARDA DEVI	
DEVELOPMENT AUTHORITY		LOCAL BODY

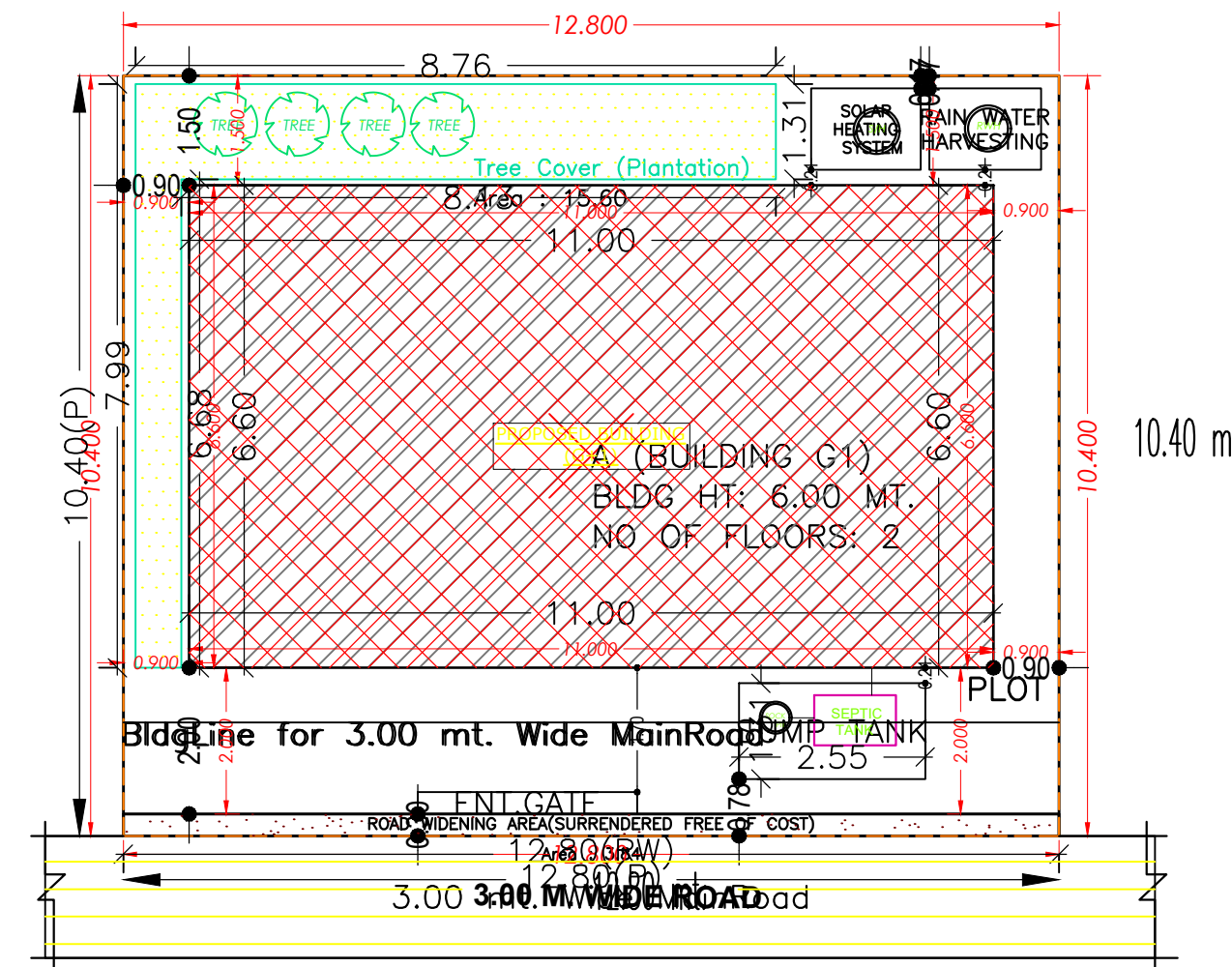

SITE PLAN
(SCALE=1:100)

SITE PLAN

Buildingwise Floor FAR Details

Floor Name	Building Name A (BUILDING G1)		Total	
	Proposed Built Up Area (Sq.mt.)	Proposed FAR Area (Sq.mt.)	Total Proposed Built Up Area (Sq.mt.)	Total FAR Area (Sq.mt.)
Ground Floor	72.60	72.60	72.60	72.60
First Floor	72.60	72.60	72.60	72.60
Terrace Floor	0.00	0.00	0.00	0.00
Total :	145.20	145.20	145.20	145.20

COLOR INDEX	
PLOT BOUNDARY	Black
ABUTTING ROAD	Green
PROPOSED CONSTRUCTION	Red
COMMON PLOT	Yellow
ROAD WIDENING AREA	Blue
EXISTING (To be retained)	Blue
EXISTING (To be demolished)	Yellow

FAR & Tenement Details (Table 4c-1)

Building	No. of Same Bldg	Total Built Up Area (Sq.mt.)	Proposed FAR Area (Sq.mt.) Resi.	Total FAR Area (Sq.mt.)	Total Consumed Additional FAR Area (Sq.mt.)	Tnmt (No.)
A (BUILDING G1)	1	145.20	145.20	145.20	145.20	01
Grand Total :	1	145.20	145.20	145.20	145.20	01

LTP NAME AND SIGNATURE	STRUCTURAL ENG'S NAME AND SIGNATURE	BUILDER NAME AND SIGNATURE	DIGITAL SIGNATURE
Navin Kumar Mandal PNPC/ENG/0004/2019			

Proposal Basic Information	
Proposal File No.	PNPC/BP/0005/W03/2021
Owner Name	AJIT KUMAR JHA & SMT SHARDA DEVI
Khata No	602
Plot No	1222
Village Name	Pakur
Use	Residential
SubUse	Bungalow/ Dwelling / Non Apartment

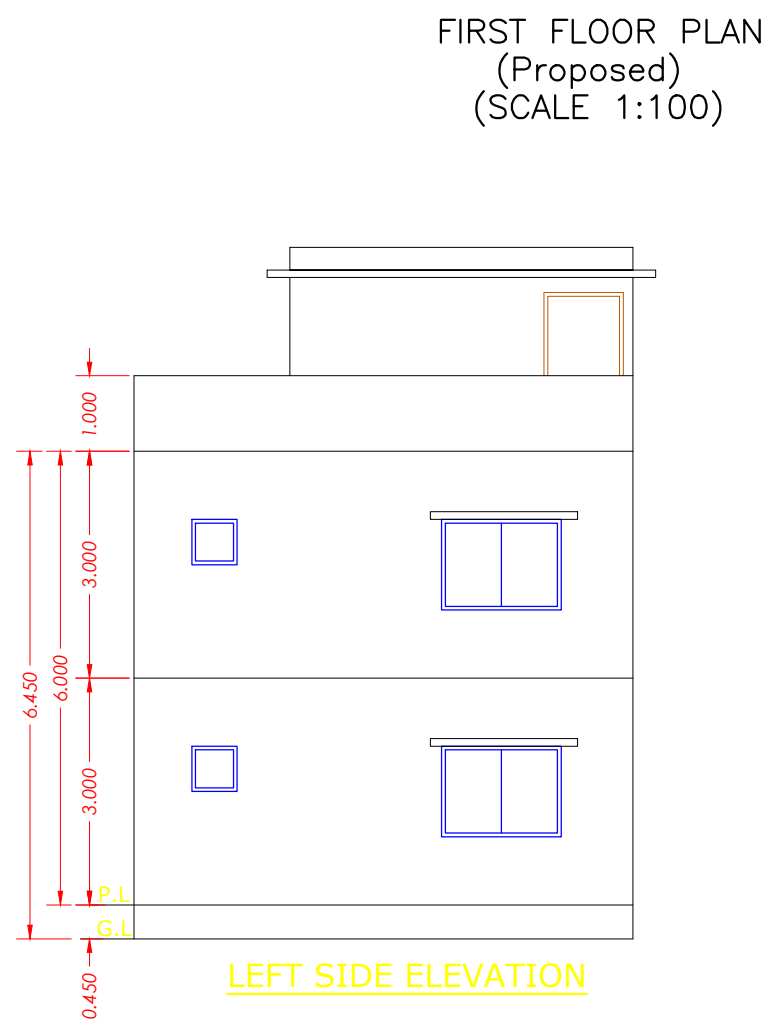
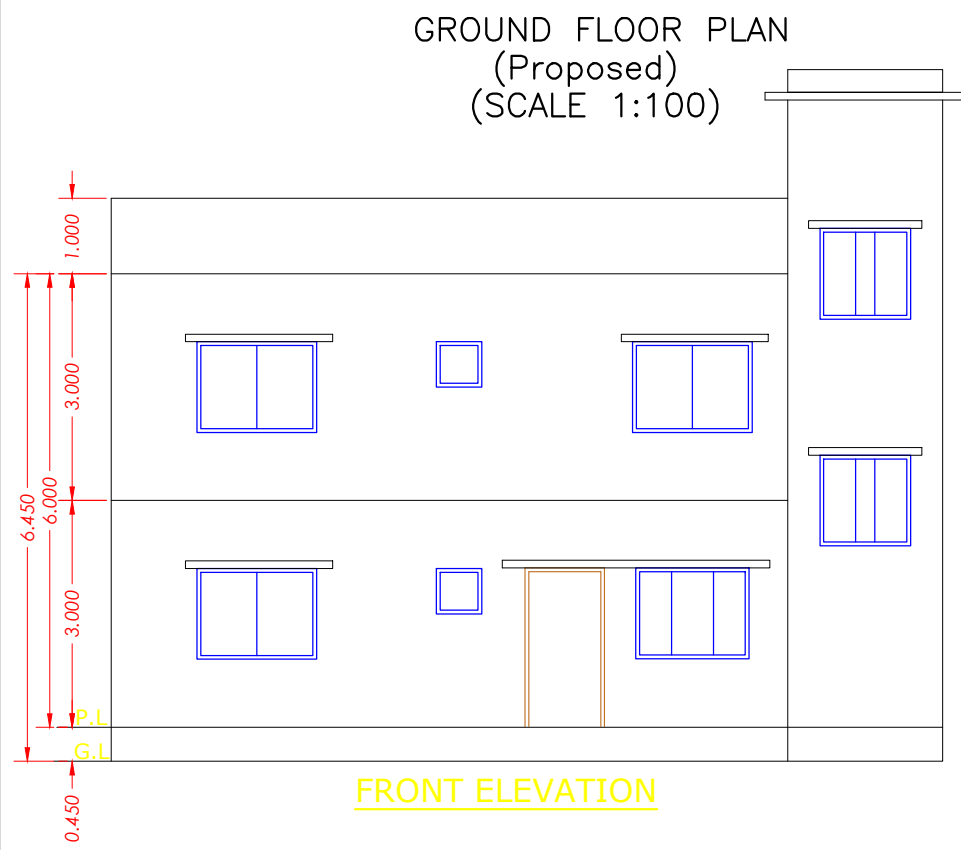
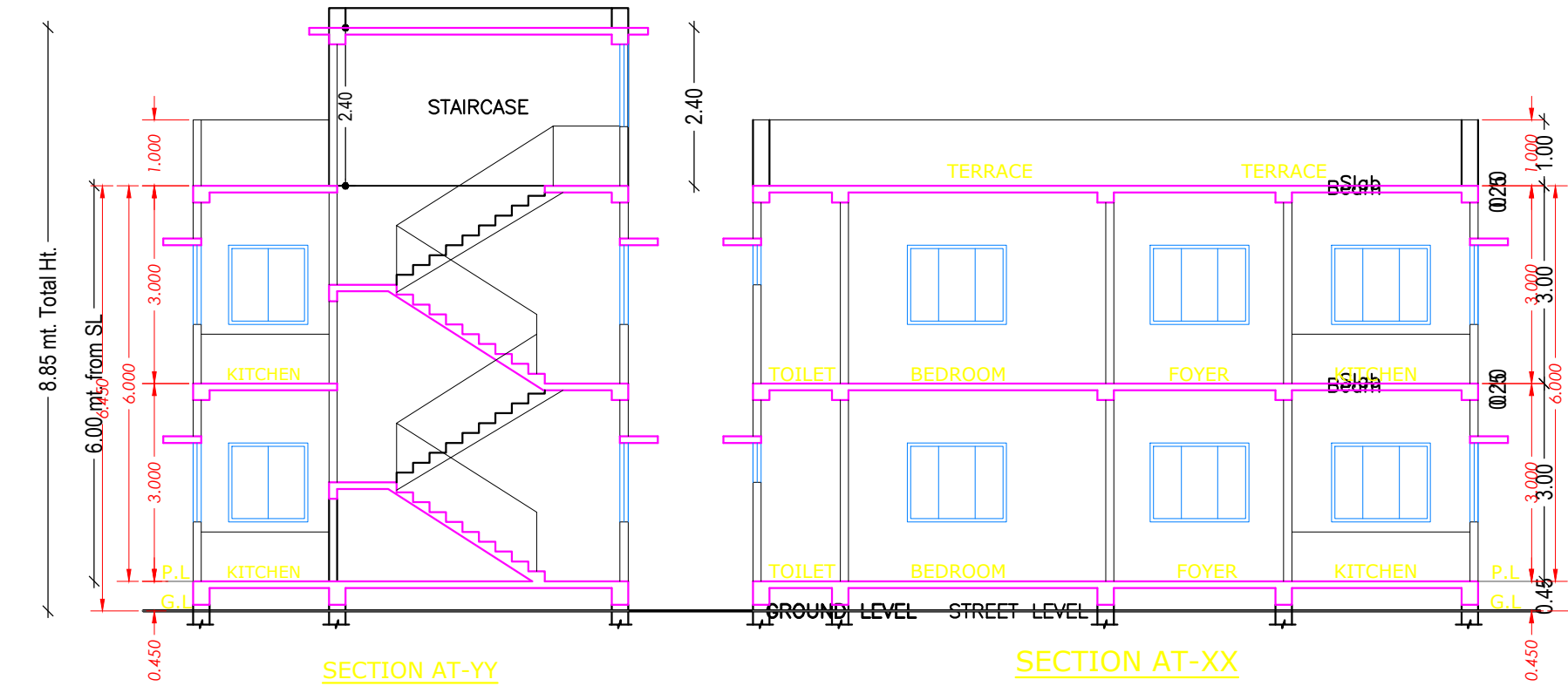
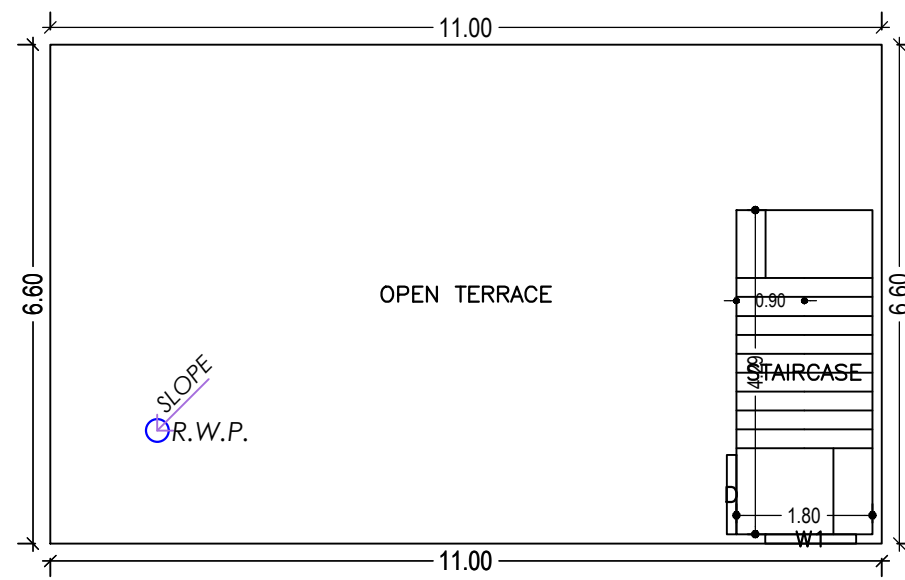
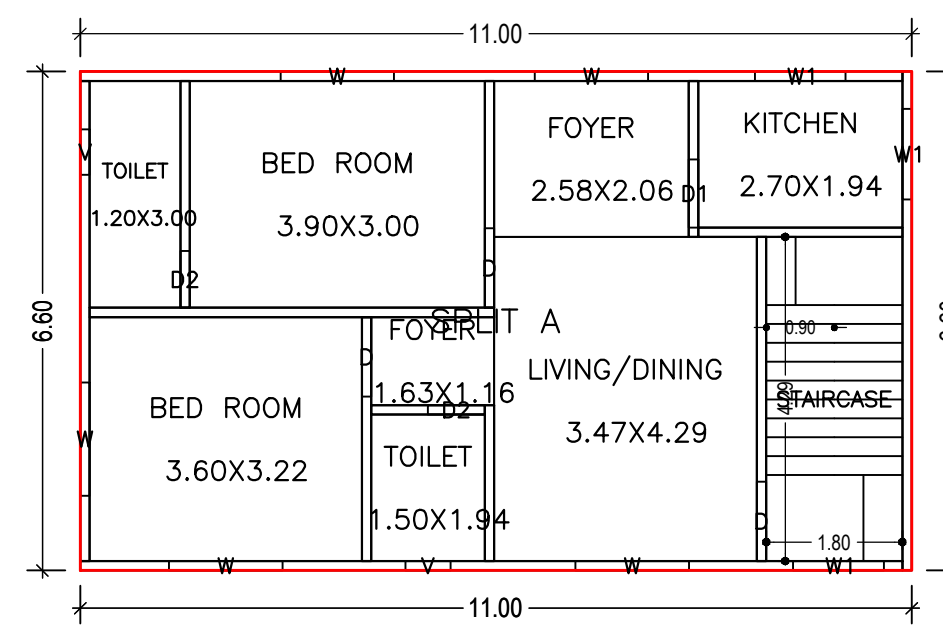
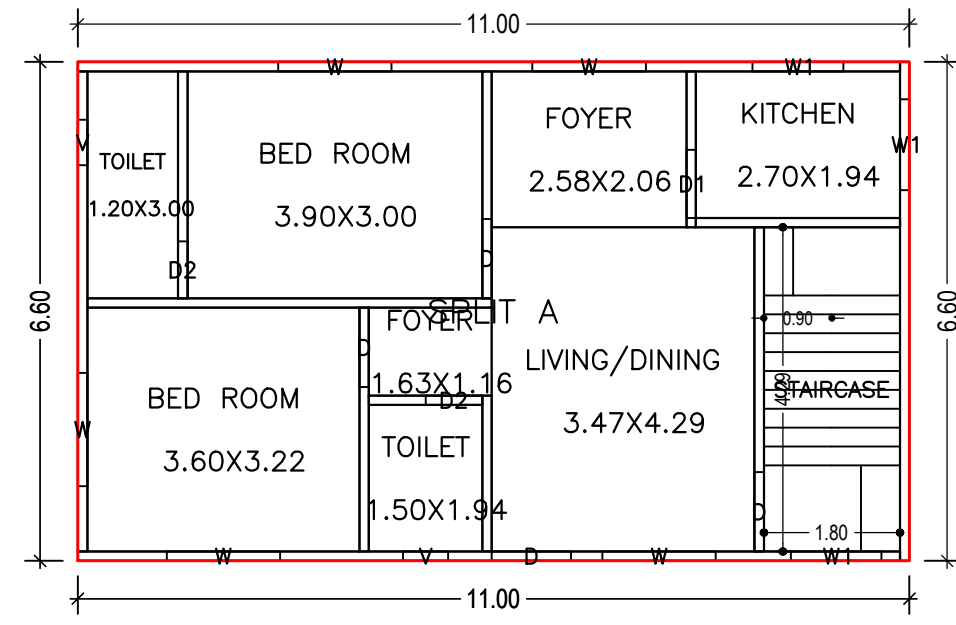

SCHEDULE OF DOOR:

BUILDING NAME	NAME	LENGTH	HEIGHT	NOS
A (BUILDING G1)	D2	0.75	2.10	04
A (BUILDING G1)	D1	0.90	2.10	02
A (BUILDING G1)	D	1.05	2.10	07

SCHEDULE OF WINDOW/VENTILATION:

BUILDING NAME	NAME	LENGTH	HEIGHT	NOS
A (BUILDING G1)	V	0.60	0.60	04
A (BUILDING G1)	W1	1.20	1.20	07
A (BUILDING G1)	W	1.50	1.20	10

Building :A (BUILDING G1)

Floor Name	Total Built Up Area (Sq.mt.)	Proposed FAR Area (Sq.mt.) Resi.	Total FAR Area (Sq.mt.)	Total Consumed Additional FAR Area (Sq.mt.)	Tnmt (No.)
Ground Floor	72.60	72.60	72.60	72.60	01
First Floor	72.60	72.60	72.60	72.60	00
Terrace Floor	0.00	0.00	0.00	0.00	00
Total :	145.20	145.20	145.20	145.20	01
Total Number of Same Buildings :	1				
Total :	145.20	145.20	145.20	145.20	01

UnitBUA Table for Building :A (BUILDING G1)

FLOOR	Name	UnitBUA Type	UnitBUA Area	Carpet Area	No. of Rooms	No. of Tenement
GROUND FLOOR PLAN	SPLIT A	FLAT	145.20	129.73	8	1
FIRST FLOOR PLAN	SPLIT A	FLAT	0.00	0.00	8	0
Total:	-	-	145.20	129.73	16	1

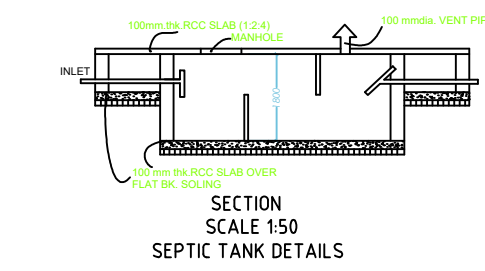
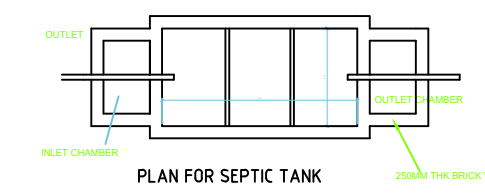

CERTIFICATE
This is to certify that the structural design of this building will be as per IS 1893-1984 & 4326-1993 to make the same Earth quake resistant.

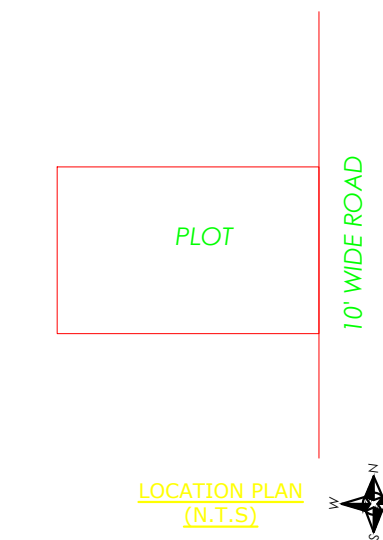
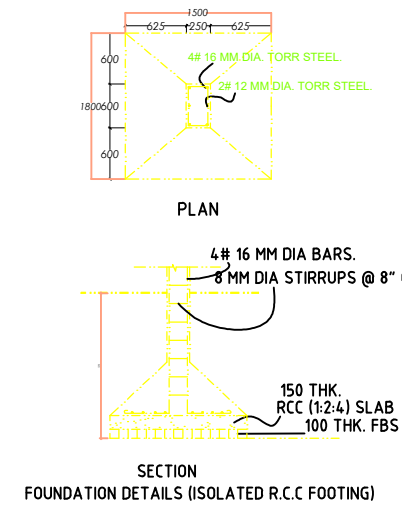
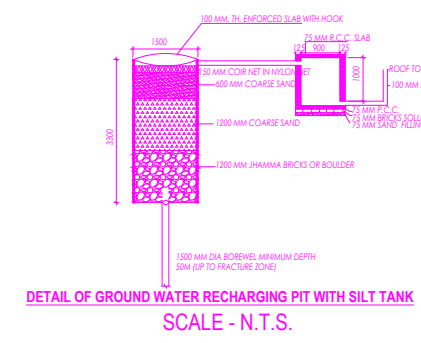
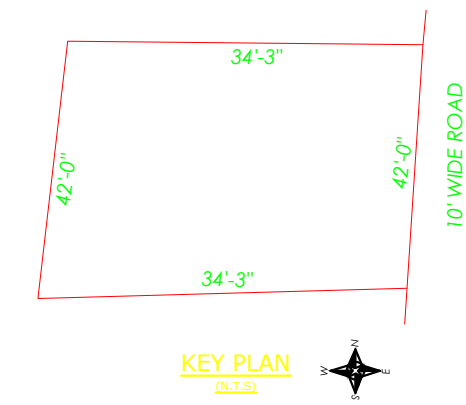

LTP NAME AND SIGNATURE	STRUCTURAL ENG'S NAME AND SIGNATURE	BUILDER NAME AND SIGNATURE	DIGITAL SIGNATURE
Navin Kumar Mandal PNPC/ENG/0004/2019			