

Project Title : RAJIB KUMAR

| AREA STATEMENT FAKIR NAGAR PARISHAD | | VERSION NO. 1.0.31 |
|--------------------------------------|-------------------------------|--------------------------|
| PROJECT DETAIL | | VERSION DATE: 16/10/2020 |
| Owner No. | Plot Use: Commercial | |
| Region: JHARKHAND URBAN LOCAL BODIES | Plot SubUse: Res/Comm Bldg | |
| District: PAKUR | Land Use Zone: NA | |
| Proposition Type: General Proposal | Abutting Road Width: - | |
| Project Type: Building Permission | Plot No.: | |
| Nature of Development: New | Revised Survey No/Survey No.: | |
| Location: Old Area | Thana No.: | |
| Plot Location: NA | Holding No.: | |
| Wing/Block Name: - | Khata No.: | |
| Ward No.: | North: | |
| Road Sheet: | South: | |
| | East: | |
| | West: | |

| THREE DETAILS | | (A) | SQ.MT. |
|--|--|--------|--------|
| AREA OF PLOT (Minimum) | | 133.78 | |
| Net Plot Area (Gross Plot Area - Deduction from Green Plot area) | | 133.78 | |
| Balance Plot Area (Net Plot Area - Deduction from Green Plot area) | | 133.78 | |
| Plot Area for Coverage (Net Plot Area) | | 133.78 | |
| Plot Area for FSI (Net Plot Area - North/South Area) | | 133.78 | |

| COVERAGES CHECK | | | |
|---------------------------------|--|-------|--|
| Proposed Coverage Area (40.27%) | | 53.88 | |
| Total Coverage Area (40.27%) | | 53.88 | |

| FAR CHECK | | | |
|----------------------|--|--------|--|
| Proposed Area of FAR | | 221.79 | |
| Total Area of FAR | | 221.79 | |

| BUILT UP AREA CHECK | | | |
|------------------------------------|------------|--------|--|
| Total Proposed Built Up Area | | 228.95 | |
| APPOINT ENGINEER/SUPERVISOR (Sign) | OWNER | | |
| DEVELOPMENT AUTHORITY | LOCAL BODY | | |

| COLOR INDEX | | | |
|-------------------------------|--|--|--|
| Plot Boundary | | | |
| Abutting Road | | | |
| Proposed Work (Coverage Area) | | | |
| Existing (To be retained) | | | |
| Existing (To be demolished) | | | |

| PARKING CALCULATION | | | |
|---------------------|-----------|---|------------|
| Parking Type | Prop. No. | | Prop. Area |
| Car Parking | 2 | 2 | 25.00 |
| Use Area | | | 25.00 |

| MARGIN DETAIL | | | | | | |
|--------------------------------|-------------------|--------------|-------------|--------------|--------------|--|
| Building Wing Sign | Road Name | Front Margin | Rear Margin | Side1 Margin | Side2 Margin | |
| A (COMMERCIAL CUM RESIDENTIAL) | 7.8 INCH MAINROAD | 6.10 | 4.06 | 1.52 | 0.00 | |

| FAR & Tenement Details (Table 4c-1) | | | | | | |
|-------------------------------------|------------------|------------------------------|-----------------------------|----------------------------|-------------------------|--------------|
| Building | No. of Same Bldg | Total Built Up Area (Sq.Mt.) | Deductions (Area in Sq.Mt.) | Proposed FAR Area (Sq.Mt.) | Total FAR Area (Sq.Mt.) | Tenent (No.) |
| A (COMMERCIAL CUM RESIDENTIAL) | 1 | 228.95 | 6.27 | 55.97 | 165.82 | 221.79 |
| Grand Total | 1 | 228.95 | 6.27 | 55.97 | 165.82 | 221.79 |

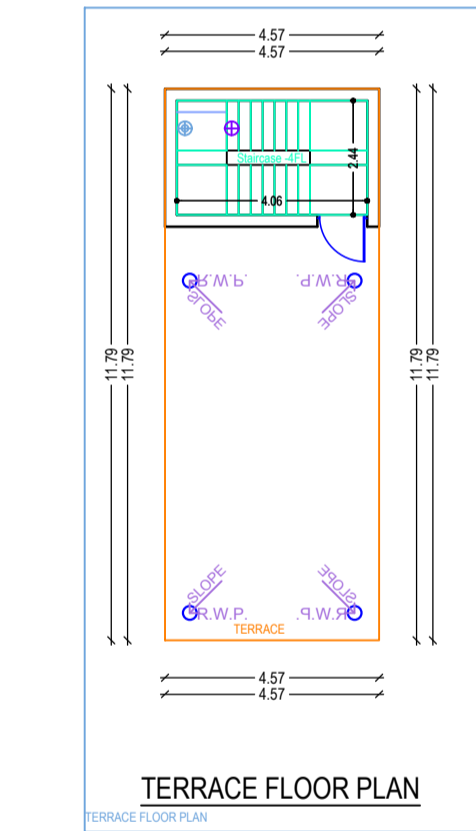
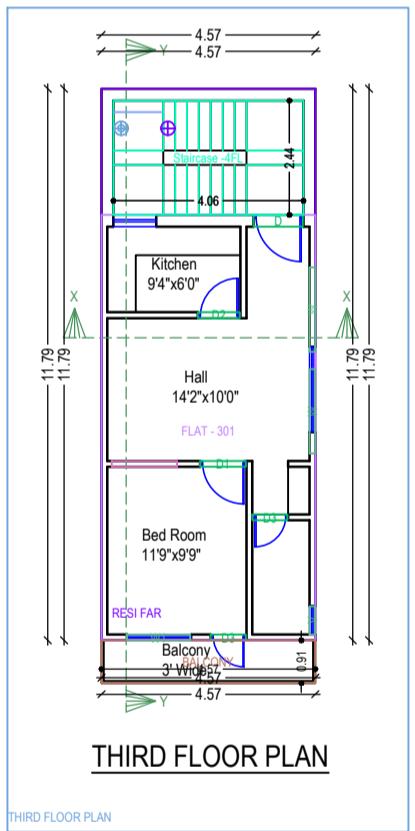
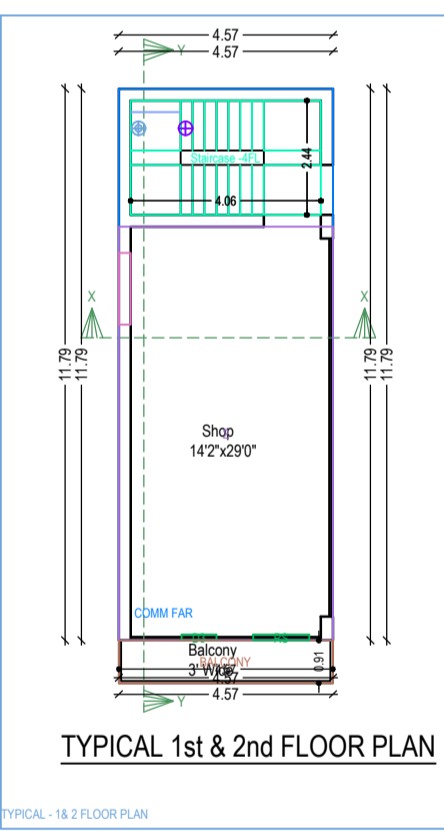
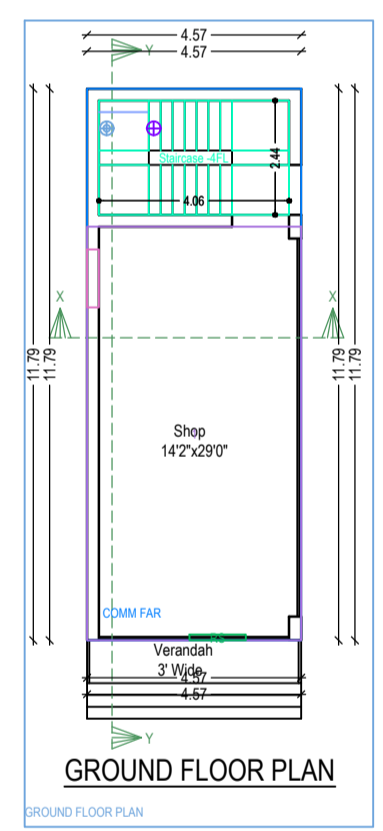
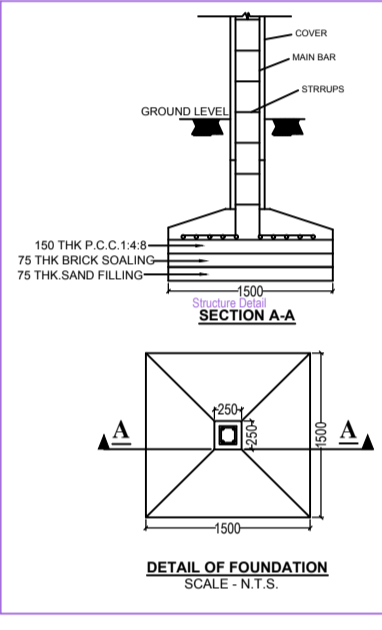
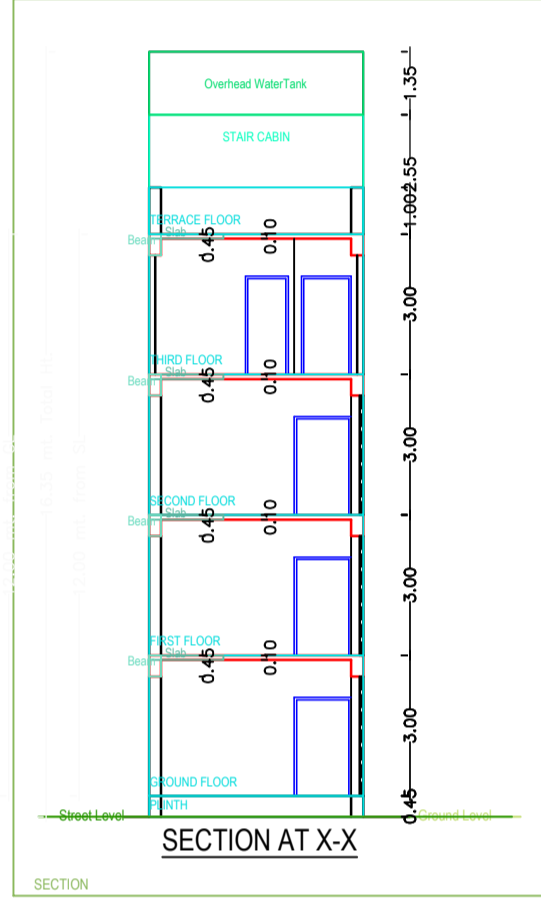
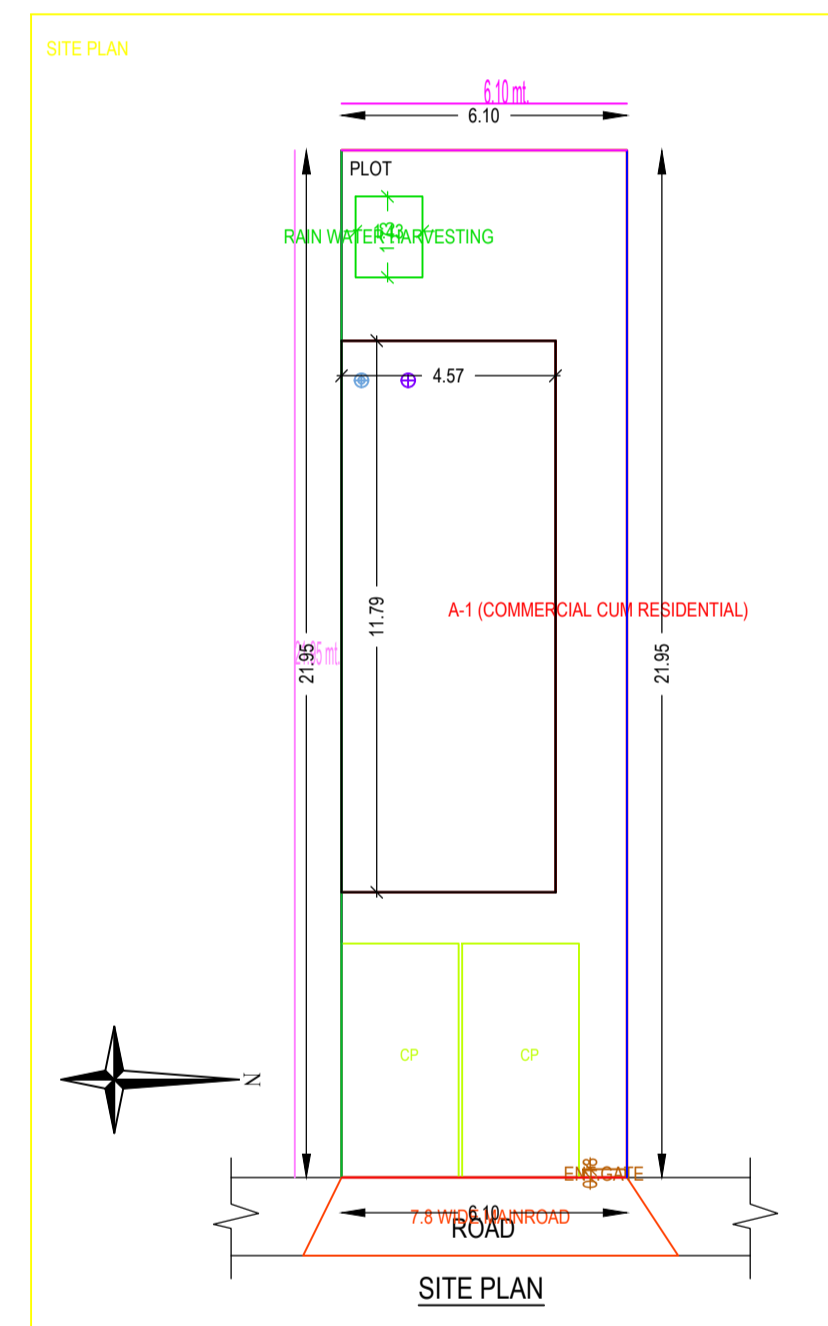

| Building A (COMMERCIAL CUM RESIDENTIAL) | | | | | | |
|---|------------------------------|-----------------------------|----------------------------|-------------------------|--------------|----|
| Floor Name | Total Built Up Area (Sq.Mt.) | Deductions (Area in Sq.Mt.) | Proposed FAR Area (Sq.Mt.) | Total FAR Area (Sq.Mt.) | Tenent (No.) | |
| Ground Floor | 33.88 | 0.00 | 0.00 | 33.88 | 00 | |
| First Floor | 58.06 | 2.00 | 0.00 | 55.97 | 00 | |
| Second Floor | 58.06 | 2.00 | 0.00 | 55.97 | 00 | |
| Third Floor | 58.06 | 2.00 | 0.00 | 55.97 | 01 | |
| Terrace Floor | 0.50 | 0.00 | 0.00 | 0.00 | 00 | |
| Total | 208.56 | 6.27 | 55.97 | 165.82 | 221.79 | 01 |

| SCHEDULE OF JOINERY: | | | | | |
|--------------------------------|------|--------|--------|-----|--|
| BUILDING NAME | NAME | LENGTH | HEIGHT | NOS | |
| A (COMMERCIAL CUM RESIDENTIAL) | 03 | 0.75 | 2.10 | 04 | |
| A (COMMERCIAL CUM RESIDENTIAL) | 02 | 0.90 | 2.10 | 01 | |
| A (COMMERCIAL CUM RESIDENTIAL) | 01 | 0.98 | 2.10 | 01 | |
| A (COMMERCIAL CUM RESIDENTIAL) | 0 | 1.00 | 2.10 | 01 | |
| A (COMMERCIAL CUM RESIDENTIAL) | RS | 1.20 | 2.10 | 03 | |
| Total | | | | 10 | |

| SCHEDULE OF JOINERY: | | | | | |
|--------------------------------|------|--------|--------|-----|--|
| BUILDING NAME | NAME | LENGTH | HEIGHT | NOS | |
| A (COMMERCIAL CUM RESIDENTIAL) | V | 0.60 | 1.00 | 01 | |
| A (COMMERCIAL CUM RESIDENTIAL) | W1 | 1.35 | 1.20 | 01 | |
| A (COMMERCIAL CUM RESIDENTIAL) | W | 1.80 | 1.20 | 03 | |
| Total | | | | 05 | |

| Balcony Calculations Table | | | |
|--------------------------------|---------------------|------|------------|
| FLOOR | SIZE | AREA | TOTAL AREA |
| THIRD FLOOR PLAN | 0.92 X 4.57 X 1 X 1 | 4.18 | 4.18 |
| TYPICAL - 1st & 2nd FLOOR PLAN | 0.90 X 4.57 X 1 X 2 | 8.36 | 8.36 |
| Total | | | 12.54 |

| UnIBUA Table for Building A (COMMERCIAL CUM RESIDENTIAL) | | | | | | |
|--|------------|-------------|-------------|-------------|--------------|-----------------|
| FLOOR | Name | UNIBUA Type | UnIBUA Area | Chapel Area | No. of Rooms | No. of Tenement |
| GROUND FLOOR PLAN | 1 | SHOP | 40.41 | 40.10 | 1 | 1 |
| TYPICAL - 1st & 2nd FLOOR PLAN | 2 | SHOP | 42.50 | 42.11 | 1 | 2 |
| THIRD FLOOR PLAN | FLAT - 301 | FLAT | 43.66 | 43.49 | 4 | 1 |
| Total | | | 126.57 | 125.80 | 7 | 4 |