

SITE PLAN

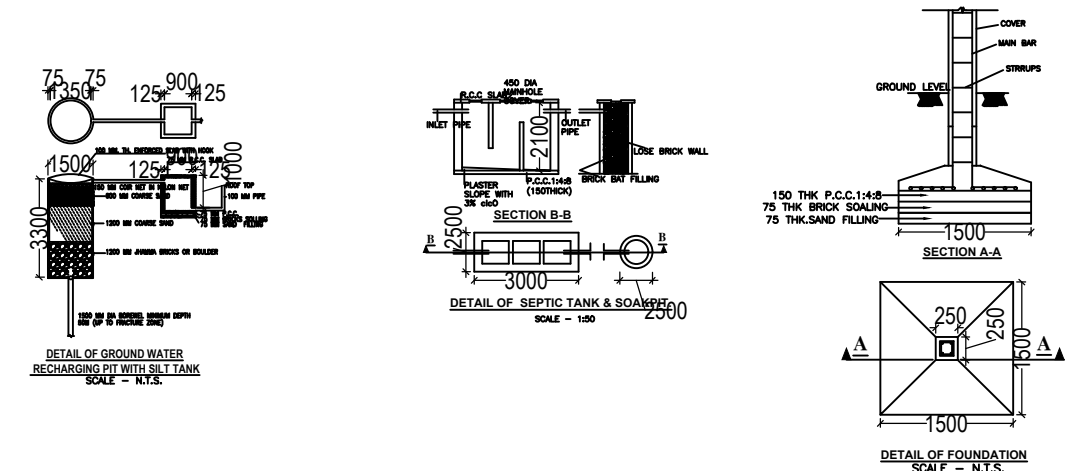

SCHEDULE OF DOOR:

BUILDING NAME	NAME	LENGTH	HEIGHT	NOS
A (RESIDENTIAL)	D	0.90	2.10	02

SCHEDULE OF WINDOW/VENTILATION:

BUILDING NAME	NAME	LENGTH	HEIGHT	NOS
A (RESIDENTIAL)	W	1.20	1.20	01

UnitBUA Table for Building :A ( RESIDENTIAL)

FLOOR	Name	UnitBUA Type	UnitBUA Area	Carpet Area	No. of Rooms	No. of Tenement
GROUND FLOOR PLAN	SPLIT A	FLAT	26.24	26.04	1	1
FIRST FLOOR PLAN	SPLIT A	FLAT	0.00	0.00	1	0
Total	-	-	26.24	26.04	2	1

COLOR INDEX	
PLOT BOUNDARY	Black
ABUTTING ROAD	Green
PROPOSED CONSTRUCTION	Red
COMMON PLOT	Yellow
ROAD WIDENING AREA	Orange
EXISTING (To be retained)	Blue
EXISTING (To be demolished)	Light Blue

Proposal Basic Information

Proposal File No.	PNPC/BP/0030/W16/2023
Owner Name	SANJIB KUNDU AND SUBIR KUNDU
Khata No	11
Plot No	07
Village Name	Baliharpur
Use	Residential
SubUse	Bungalow/ Dwelling / Non Apartment

AREA STATEMENT PAKUR NAGAR PARISHAD	VERSION NO.: 1.0.66	SQ.MT.
PROJECT DETAIL:	VERSION DATE: 16/10/2020	
Region: JHARKHAND URBAN LOCAL BODIES	Plot Use: Residential	
District: PAKUR	Plot SubUse: Bungalow/ Dwelling / Non Apartment	
Authority: PAKUR NAGAR PARISHAD	Plot/Nearby/Religious/Structure: NA	
Inward No: PNP/0030/W16/2023	Plot/SubPlot No: 07	
Application Type: General Proposal	North: -	
Project Type: Building Permission	South: Road Width - 4.8	
Nature of Development: New	East: -	
Location of Development Area: Old Area	West: -	
AREA DETAILS:		
AREA OF PLOT (Minimum)	(A)	26.23
NET AREA OF PLOT(Gross Plot Area - Deduction from Gross Plot area)	(A-Deductions)	26.23
Deduction for Balance Plot Area(from Gross Plot Area)		
Common Plot		4.68
Total		4.68
BALANCE AREA OF PLOT(Net Plot Area - Recreational/Amenity space)	(A-Deductions)	21.55
PLOT AREA FOR COVERAGE(Net Plot Area)	(A-Deductions)	26.23
Plot Area for FAR (Net Plot Area + Road/Widening Area)	(A-Deductions)	26.23
COVERAGE CHECK		
Permissible Coverage area ( 70.00 % )		18.36
Proposed Coverage Area ( 50.02 % )		13.12
Total Prop. Coverage Area ( 50.02 % )		13.12
Balance coverage area ( 19.98 % )		5.24
FAR CHECK		
Perm. FAR Area ( 1.800 )		47.21
Total Perm. FAR area		47.21
Residential FAR		26.24
Proposed FAR Area		26.24
Total Proposed FAR Area		26.24
Consumed FAR (Factor)		1.00
Balance FAR Area		20.97
BUILT UP AREA CHECK		
Total Proposed BuiltUp Area		26.24
ARCHITECT (Regd)	Navin Kumar Mandal	
ENGINEER (Regd)		
SUPERVISOR (Regd)		
OWNER (Regd)	SANJIB KUNDU AND SUBIR KUNDU	
DEVELOPMENT AUTHORITY	LOCAL BODY	

Buildingwise Floor FAR Details

Floor Name	Building Name A (RESIDENTIAL)		Total	
	Proposed Built Up Area (Sq.mt.)	Proposed FAR Area (Sq.mt.)	Total Proposed Built Up Area (Sq.mt.)	Total FAR Area (Sq.mt.)
Ground Floor	13.12	13.12	13.12	13.12
First Floor	13.12	13.12	13.12	13.12
Terrace Floor	0.00	0.00	0.00	0.00
Total :	26.24	26.24	26.24	26.24

Building USE/SUBUSE Details

Building Name	Building Use	Building SubUse	Building Structure
A (RESIDENTIAL)	Residential	Bungalow/ Dwelling / Non Apartment	Non-Highrise

FAR & Tenement Details (Table 4c-1)

Building	No. of Same Bldg	Total Built Up Area (Sq.mt.)	Proposed FAR Area (Sq.mt.) Resi.	Total FAR Area (Sq.mt.)	Total Consumed Additional FAR Area (Sq.mt.)	Tnmt (No.)
A (RESIDENTIAL)	1	26.24	26.24	26.24	26.24	01
Grand Total :	1	26.24	26.24	26.24	26.24	01

Building :A ( RESIDENTIAL)

Floor Name	Total Built Up Area (Sq.mt.)	Proposed FAR Area (Sq.mt.) Resi.	Total FAR Area (Sq.mt.)	Total Consumed Additional FAR Area (Sq.mt.)	Tnmt (No.)
Ground Floor	13.12	13.12	13.12	13.12	01
First Floor	13.12	13.12	13.12	13.12	00
Terrace Floor	0.00	0.00	0.00	0.00	00
Total :	26.24	26.24	26.24	26.24	01
Total Number of Same Buildings :	1				
Total :	26.24	26.24	26.24	26.24	01

LTP NAME AND SIGNATURE	STRUCTURAL ENG'S NAME AND SIGNATURE	BUILDER NAME AND SIGNATURE	DIGITAL SIGNATURE
Navin Kumar Mandal PNPC/ENG/0004/2019			