

Proposal Basic Information	
Proposal File No.	PNPC/BP/0016/W10/2023
Owner Name	SMT HARWINDAR KAUR
Khata No	619
Plot No	495
Village Name	Pakur
Use	Residential
SubUse	Bungalow/ Dwelling / Non Apartment

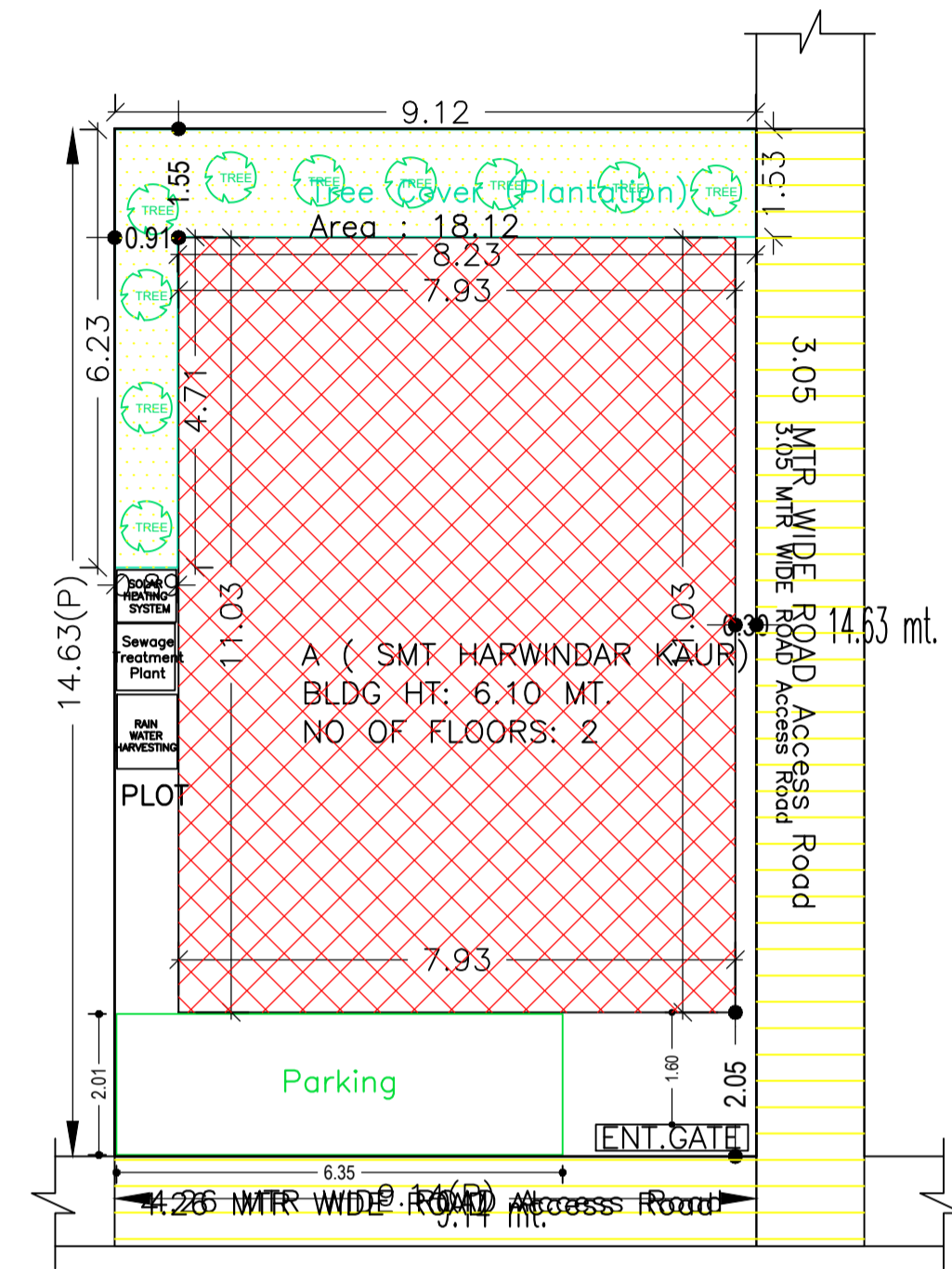

SITE PLAN

AREA STATEMENT PAKUR		VERSION NO.:	1.0.66
NAGAR PARISHAD		VERSION DATE:	16/10/2020
<b>PROJECT DETAIL:</b>			
Region: JHARKHAND URBAN LOCAL BODIES	Plot Use: Residential		
District: PAKUR	Plot SubUse: Bungalow/ Dwelling / Non Apartment		
Authority: PAKUR NAGAR PARISHAD	Plot/Nearby/Religious/Structure: NA		
Inward No: PNP/0016/W10/2023	Plot/SubPlot No: 495		
Application Type: General Proposal	North: Road Width - 4.26 MTR WIDE ROAD Access Road		
Project Type: Building Permission	South: -		
Nature of Development: New	East: -		
Location of Development Area: Old Area	West: Road Width - 3.05 MTR WIDE ROAD Access Road		
<b>AREA DETAILS:</b>			SQ.MT.
AREA OF PLOT (Minimum)	(A)		133.72
NET AREA OF PLOT(Gross Plot Area - Deduction from Gross Plot area)	(A-Deductions)		133.72
<b>Deduction for Balance Plot Area(from Gross Plot Area)</b>			
Common Plot			18.12
Total			18.12
BALANCE AREA OF PLOT(Net Plot Area - Recreational/Amenity spaces)	(A-Deductions)		115.60
PLOT AREA FOR COVERAGE(Net Plot Area)	(A-Deductions)		133.72
Plot Area for FAR (Net Plot Area + Road Widening Area)	(A-Deductions)		133.72
<b>COVERAGE CHECK</b>			
Permissible Coverage area ( 70.00 % )			93.60
Proposed Coverage Area ( 65.41 % )			87.47
Total Prop. Coverage Area ( 65.41 % )			87.47
Balance coverage area ( 4.58 % )			6.13
<b>FAR CHECK</b>			
Perm. FAR Area ( 1.500 )			200.58
Total Perm. FAR area			200.58
Residential FAR			174.94
Proposed FAR Area			174.94
Total Proposed FAR Area			174.94
Consumed FAR (Factor)			1.31
Balance FAR Area			25.64
<b>BUILT UP AREA CHECK</b>			
Total Proposed BuiltUp Area			174.94
ARCHITECT (Regd)	Samsuddin Ansari		
ENGINEER (Regd)			
SUPERVISOR (Regd)			
OWNER (Regd)	SMT HARWINDAR KAUR		
DEVELOPMENT AUTHORITY		LOCAL BODY	

COLOR INDEX	
PLOT BOUNDARY	Black
ABUTTING ROAD	Green
PROPOSED CONSTRUCTION	Red
COMMON PLOT	Yellow
ROAD WIDENING AREA	Orange
EXISTING (To be retained)	Blue
EXISTING (To be demolished)	Light Blue

Building USE/SUBUSE Details

Building Name	Building Use	Building SubUse	Building Structure
A ( SMT HARWINDAR KAUR)	Residential	Bungalow/ Dwelling / Non Apartment	Non-Highrise

Buildingwise Floor FAR Details

Floor Name	Building Name		Total	
	A ( SMT HARWINDAR KAUR)	Proposed FAR Area (Sq.mt.)	Total Proposed Built Up Area (Sq.mt.)	Total FAR Area (Sq.mt.)
Ground Floor	87.47	87.47	87.47	87.47
First Floor	87.47	87.47	87.47	87.47
Terrace Floor	0.00	0.00	0.00	0.00
Total :	174.94	174.94	174.94	174.94

FAR & Tenement Details (Table 4c-1)

Building	No. of Same Bldg	Total Built Up Area (Sq.mt.)	Proposed FAR Area (Sq.mt.) Resi.	Total FAR Area (Sq.mt.)	Total Consumed Additional FAR Area (Sq.mt.)	Tnmt (No.)
A ( SMT HARWINDAR KAUR)	1	174.94	174.94	174.94	174.94	01
Grand Total :	1	174.94	174.94	174.94	174.94	01

LTP NAME AND SIGNATURE	STRUCTURAL ENG'S NAME AND SIGNATURE	BUILDER NAME AND SIGNATURE	DIGITAL SIGNATURE
Samsuddin Ansari PNPC/SUP/0003/2017			

Proposal Basic Information	
Proposal File No.	PNPC/BP/0016/W10/2023
Owner Name	SMT HARWINDAR KAUR
Khata No	619
Plot No	495
Village Name	Pakur
Use	Residential
SubUse	Bungalow/ Dwelling / Non Apartment

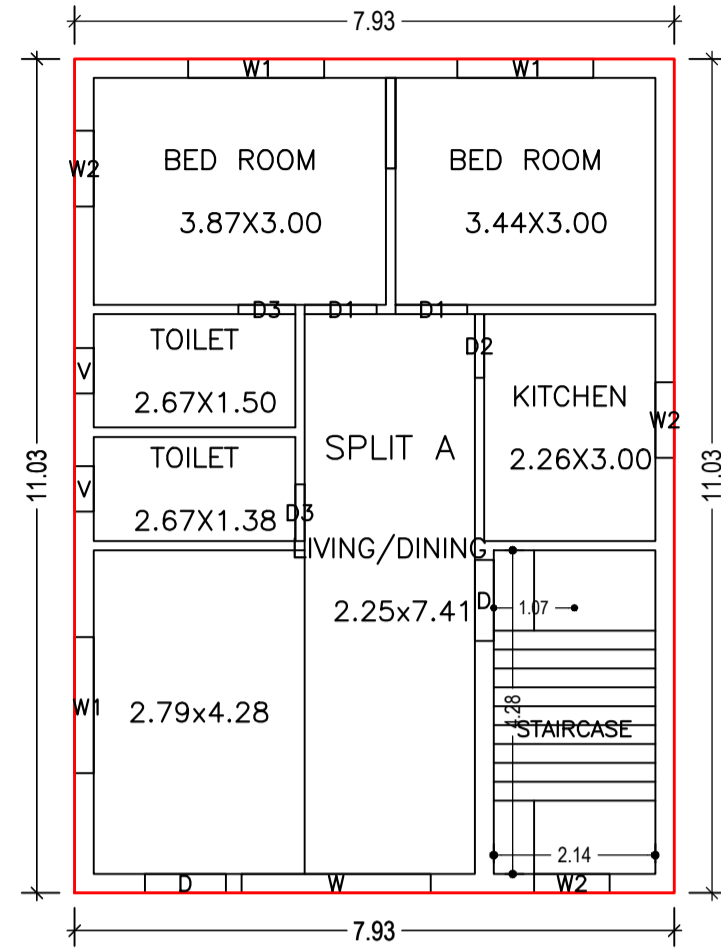

GROUND FLOOR PLAN  
(Proposed)  
(SCALE 1:100)

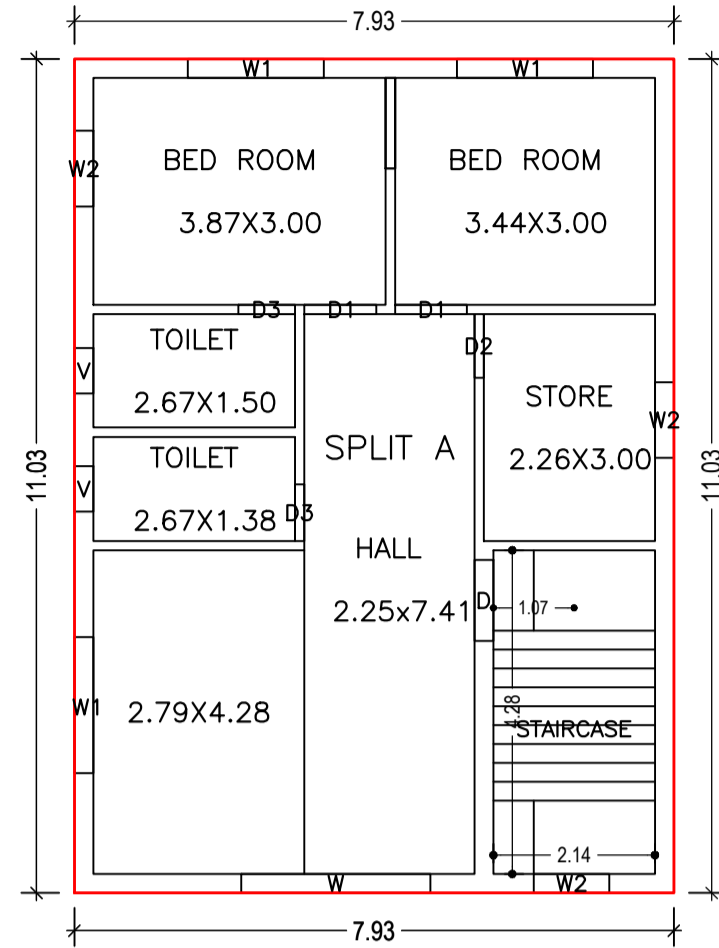

FIRST FLOOR PLAN  
(Proposed)  
(SCALE 1:100)

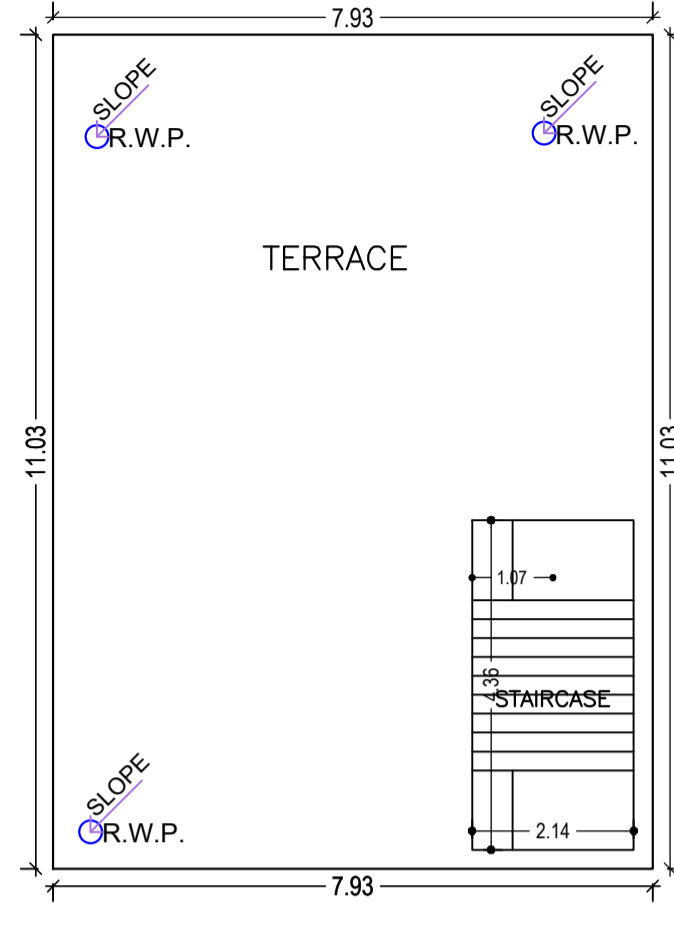

TERRACE FLOOR PLAN  
(SCALE 1:100)

Building :A ( SMT HARWINDAR KAUR)

Floor Name	Total Built Up Area (Sq.mt.)	Proposed FAR Area (Sq.mt.) Resi.	Total FAR Area (Sq.mt.)	Total Consumed Additional FAR Area (Sq.mt.)	Tnmt (No.)
Ground Floor	87.47	87.47	87.47	87.47	01
First Floor	87.47	87.47	87.47	87.47	00
Terrace Floor	0.00	0.00	0.00	0.00	00
Total	174.94	174.94	174.94	174.94	01
Total Number of Same Buildings	1				
Total	174.94	174.94	174.94	174.94	01

SCHEDULE OF DOOR:

BUILDING NAME	NAME	LENGTH	HEIGHT	NOS
A ( SMT HARWINDAR KAUR)	D3	0.75	2.13	04
A ( SMT HARWINDAR KAUR)	D2	0.84	2.13	02
A ( SMT HARWINDAR KAUR)	D1	0.95	2.13	04
A ( SMT HARWINDAR KAUR)	D	1.07	2.13	03

SCHEDULE OF WINDOW/VENTILATION:

BUILDING NAME	NAME	LENGTH	HEIGHT	NOS
A ( SMT HARWINDAR KAUR)	V	0.60	2.00	04
A ( SMT HARWINDAR KAUR)	W2	1.00	2.70	06
A ( SMT HARWINDAR KAUR)	W1	1.80	2.70	06
A ( SMT HARWINDAR KAUR)	W	2.50	2.50	02

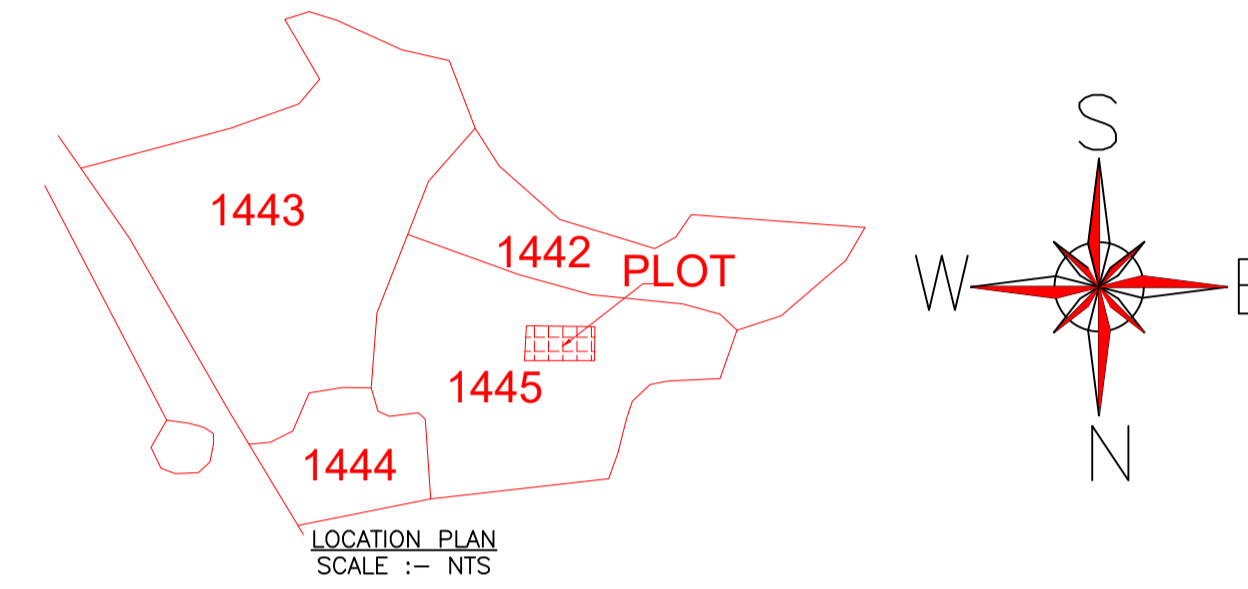

UnitBUA Table for Building :A ( SMT HARWINDAR KAUR)

FLOOR	Name	UnitBUA Type	UnitBUA Area	Carpet Area	No. of Rooms	No. of Tenement
GROUND FLOOR PLAN	SPLIT A	FLAT	135.44	135.14	6	1
FIRST FLOOR PLAN	SPLIT A	FLAT	0.00	0.00	6	0
Total:	-	-	135.44	135.14	12	1

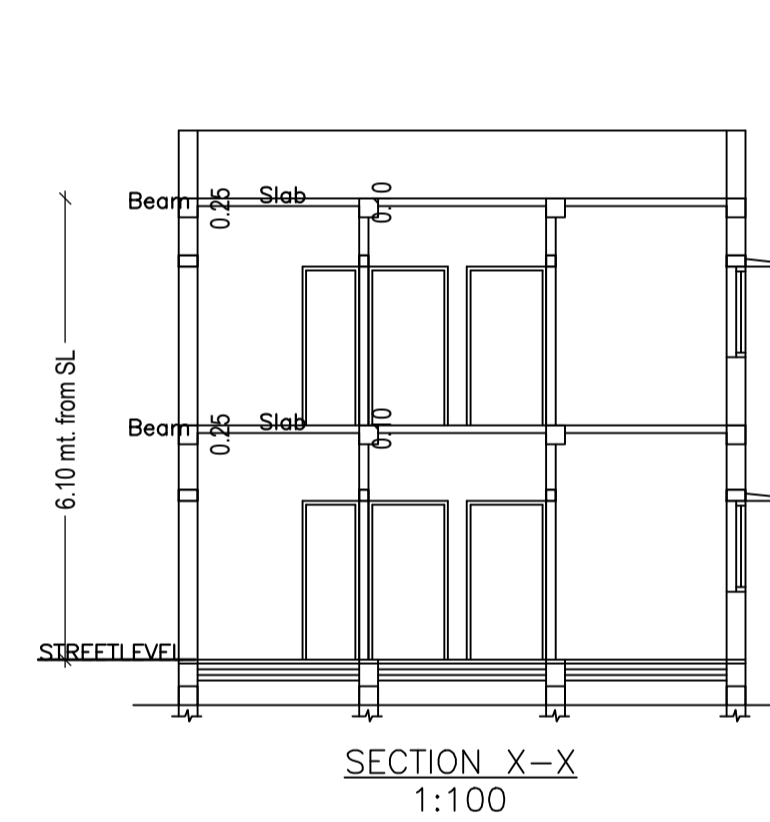

SECTION X-X  
1:100

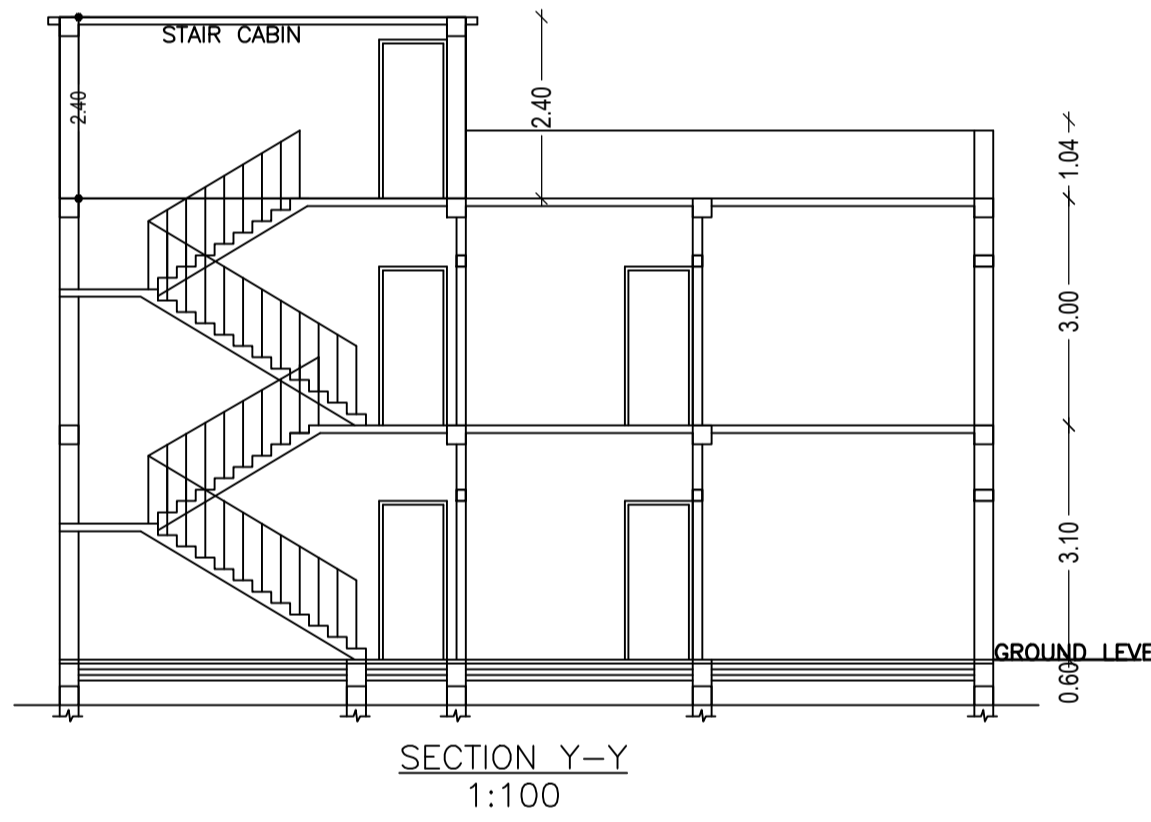

SECTION Y-Y  
1:100

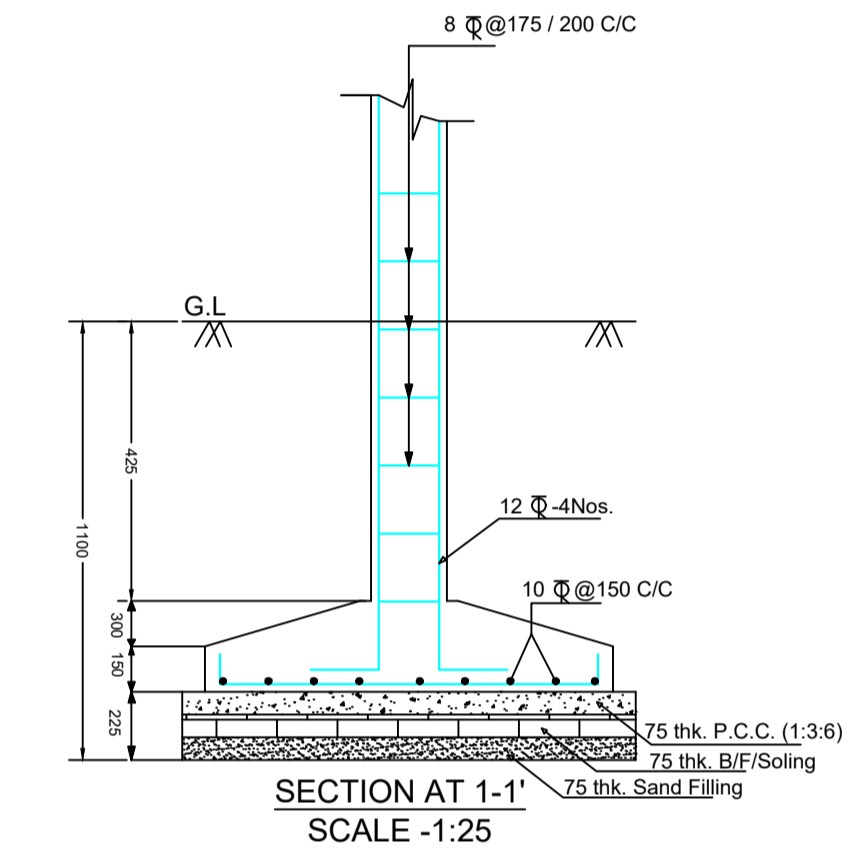

SECTION AT 1-1'  
SCALE -1:25

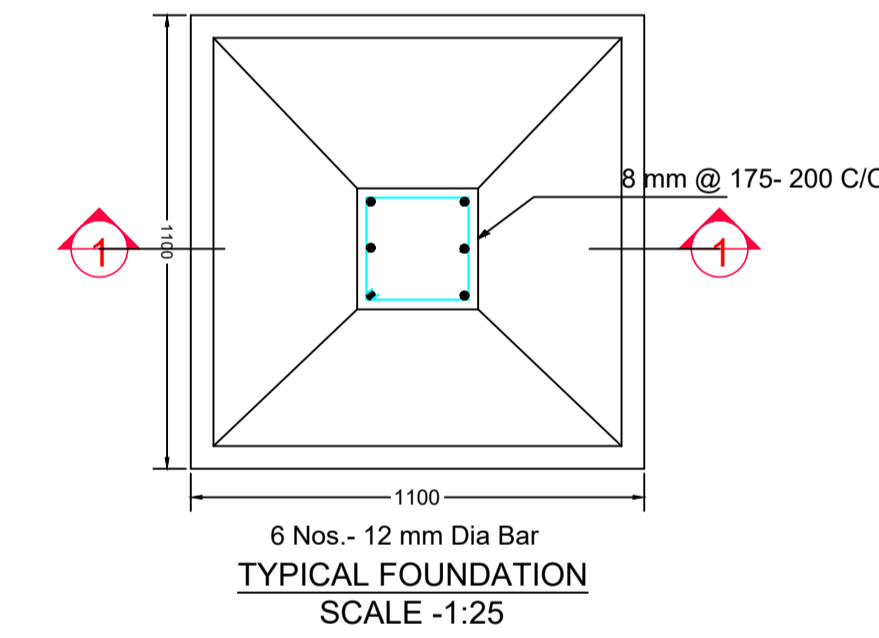

TYPICAL FOUNDATION  
SCALE -1:25

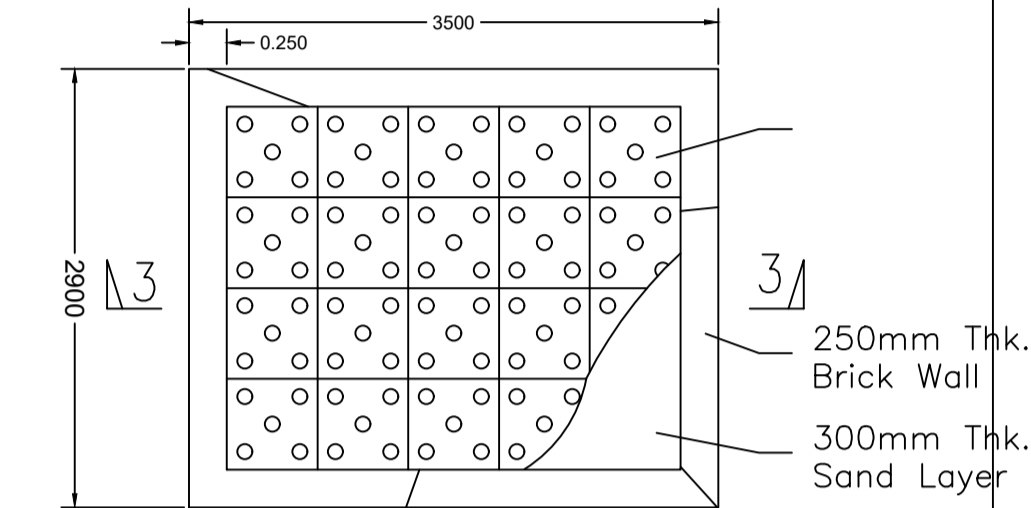

PLAN OF RAIN WATER RECHARGE PIT  
Scale - (1:50)

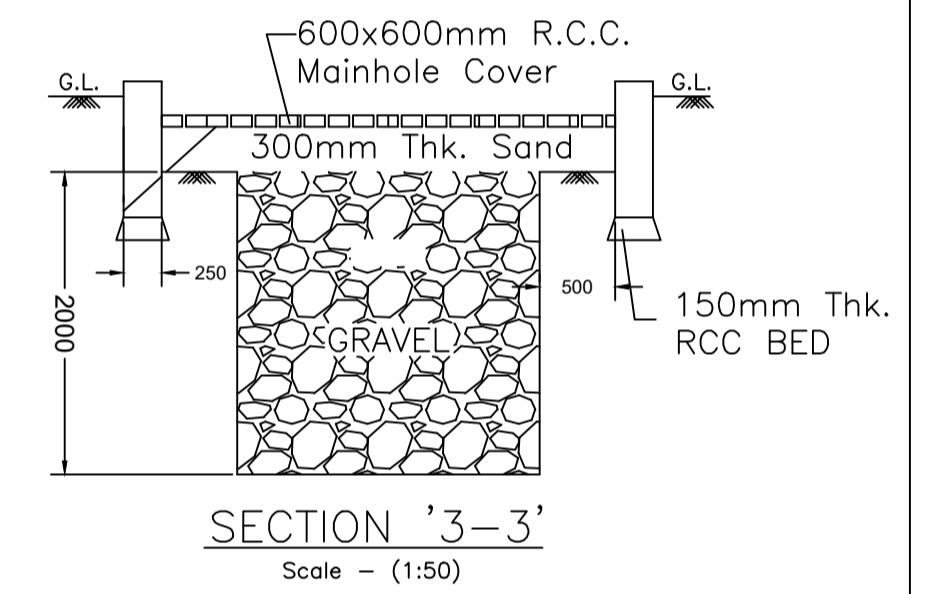

SECTION '3-3'  
Scale - (1:50)



FRONT ELEVATION  
1:100

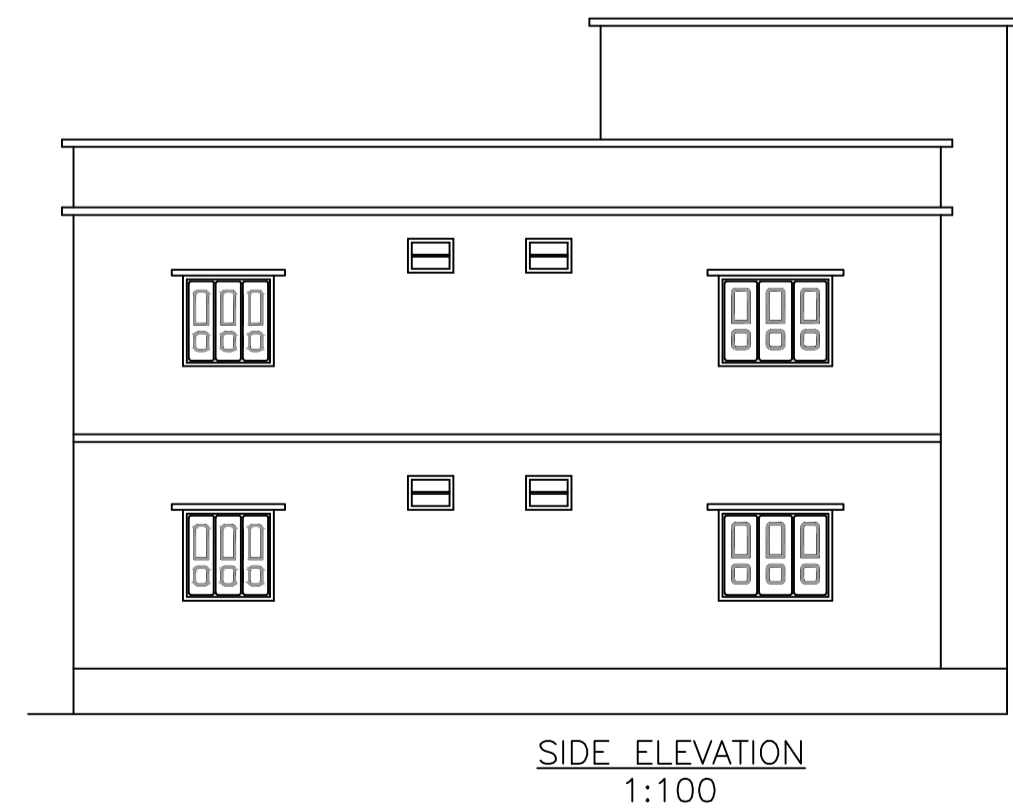

SIDE ELEVATION  
1:100

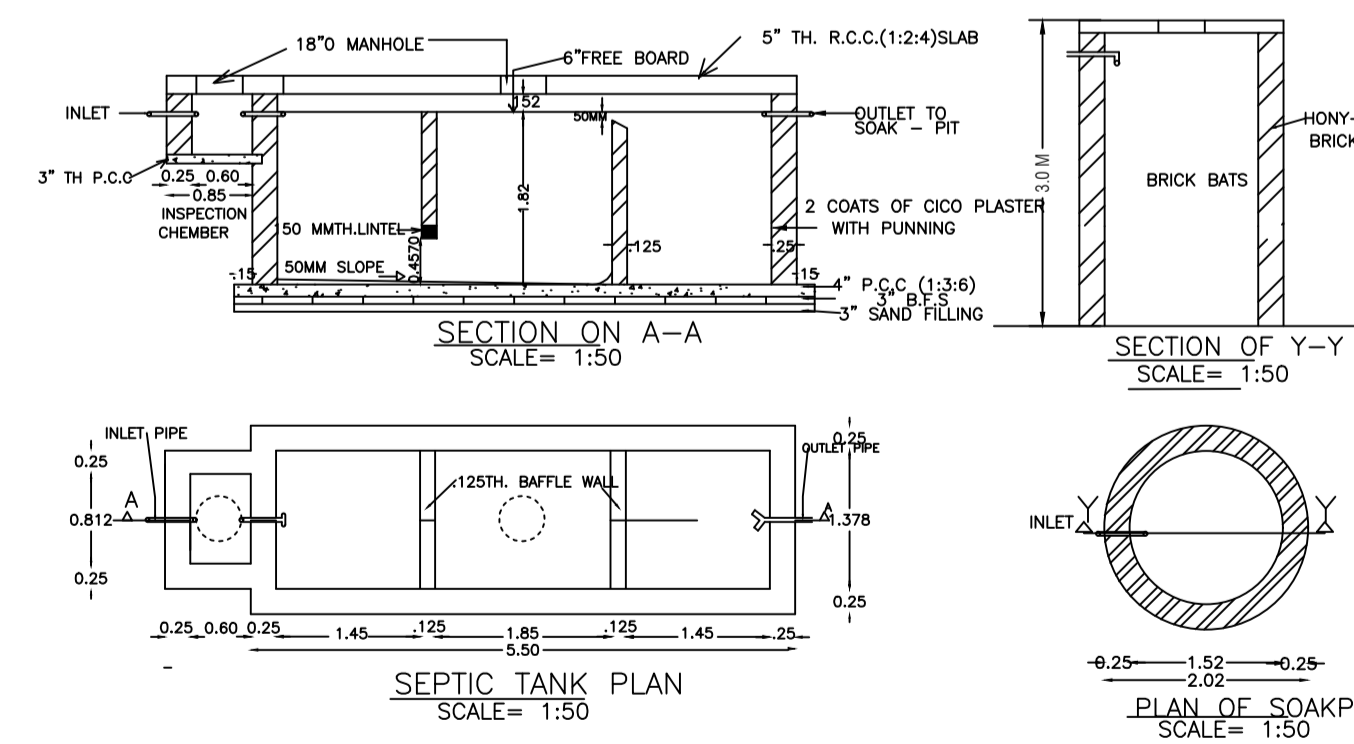

SECTION ON A-A  
SCALE= 1:50

SECTION OF Y-Y  
SCALE= 1:50

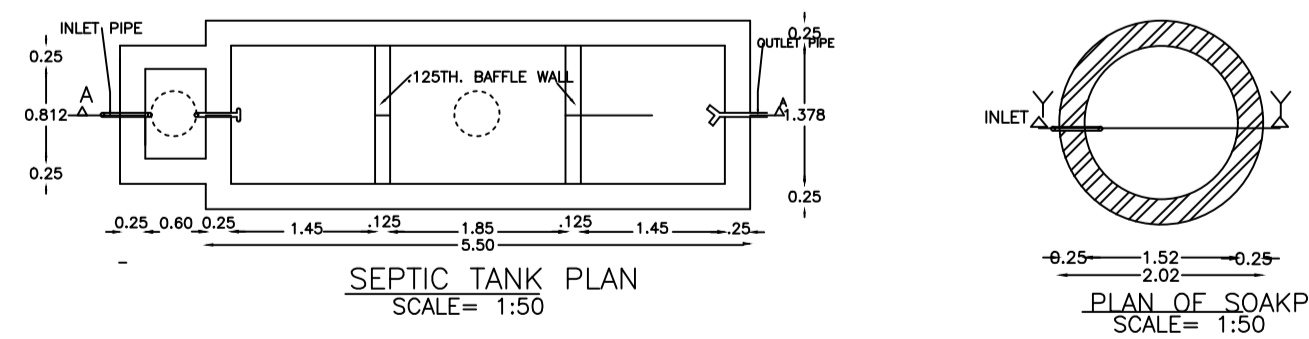

SEPTIC TANK PLAN  
SCALE= 1:50

PLAN OF SOAKPIT  
SCALE= 1:50

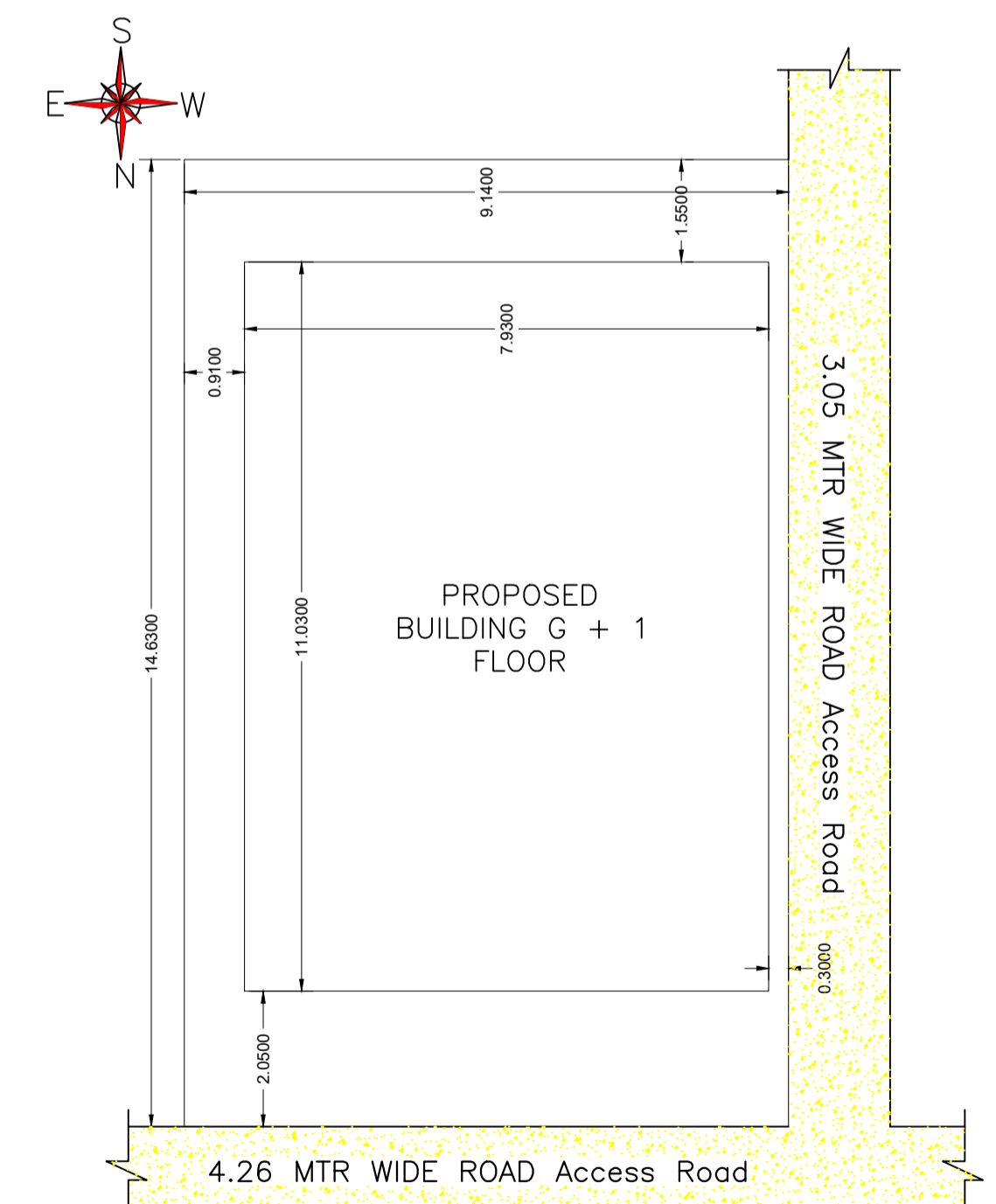

SITE PLAN  
SCALE :- 1:100

LTP NAME AND SIGNATURE	STRUCTURAL ENG'S NAME AND SIGNATURE	BUILDER NAME AND SIGNATURE	DIGITAL SIGNATURE
Samsuddin Ansari PNPC/SUP/0003/2017			