

# Project Title :MD RAFIKUL ISLAM

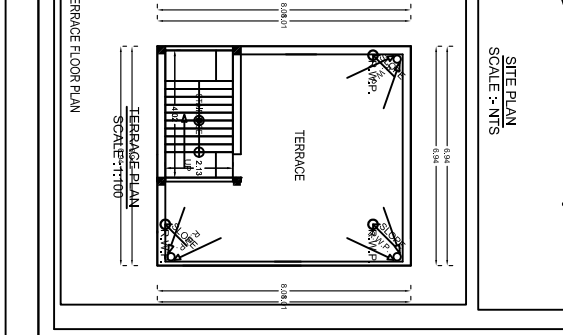
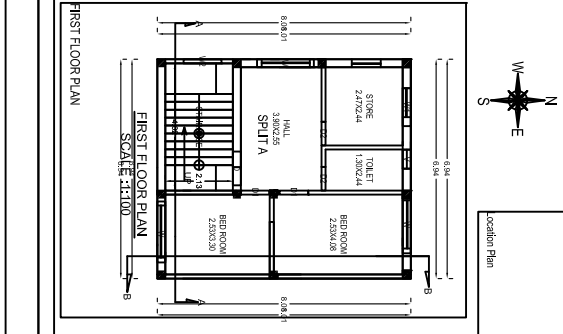
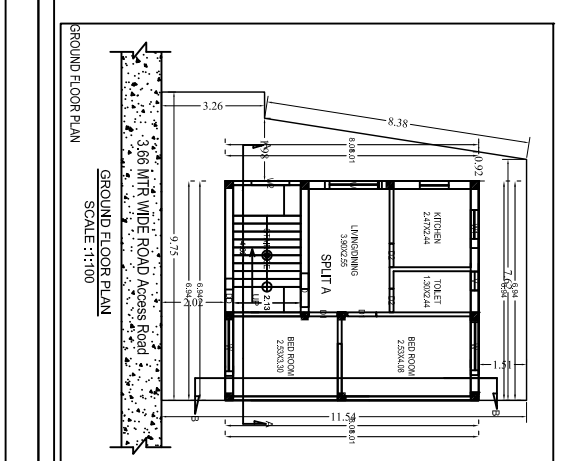
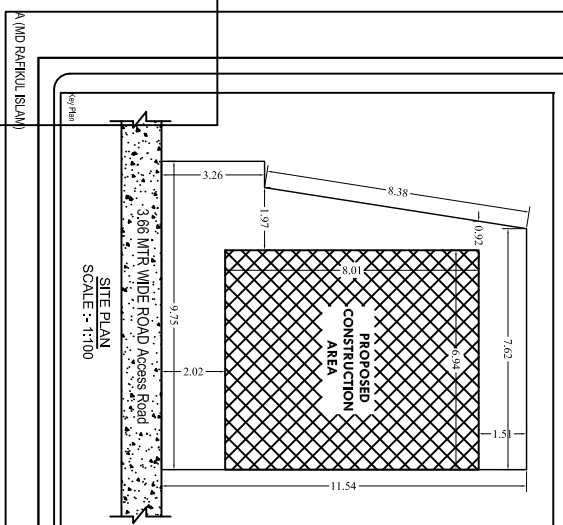
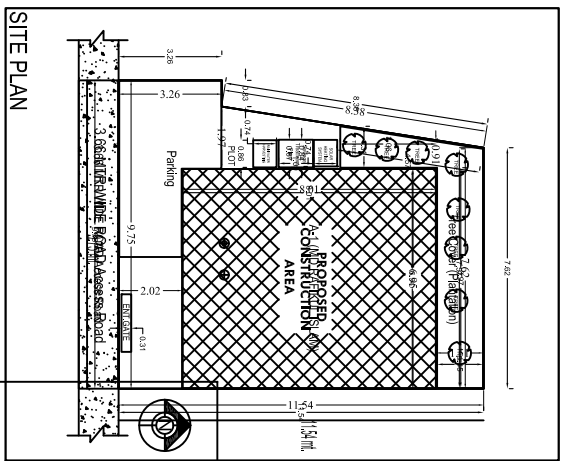
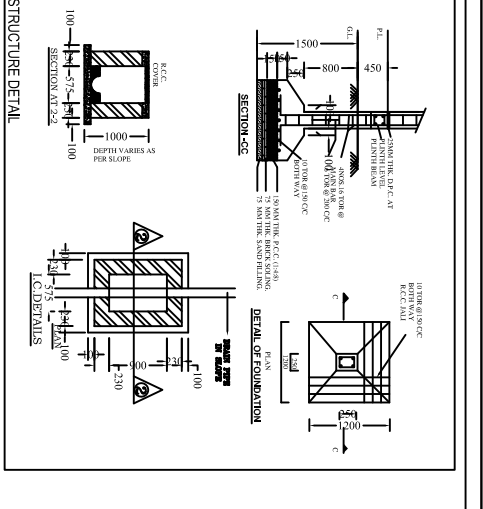
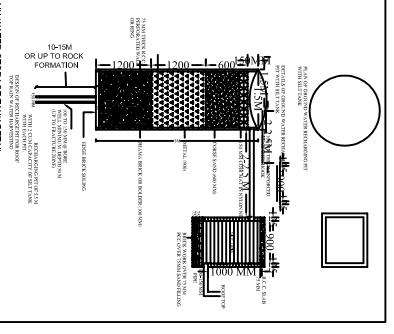
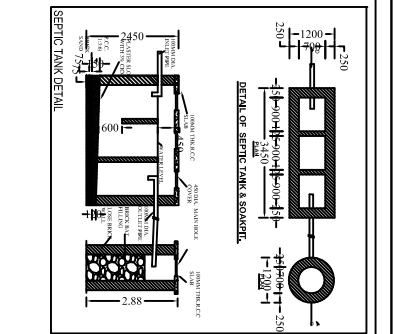
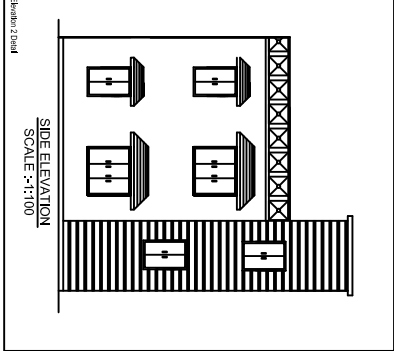
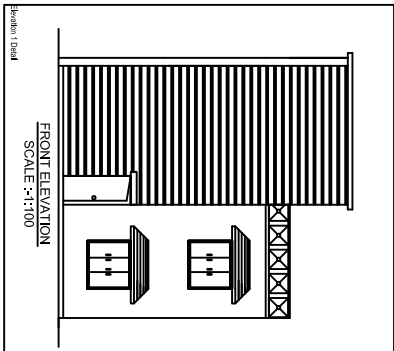
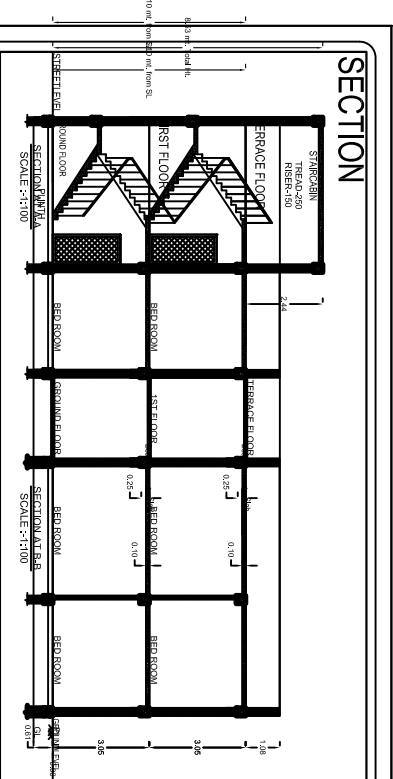

**LAND DETAILS**  
 PROPOSED RESIDENTIAL BUILDING PLAN OF  
**MD RAFIKUL ISLAM**  
 S/O- MD ARIAD AIL  
 VILLAGE - KODERMA, WARD NO-19  
 THANA NO - 333  
 DISTRICT - KODERMA, JHARKHAND

Applicant's Signature: \_\_\_\_\_  
 Signature of I.C. ENGINEER: \_\_\_\_\_

**Building 2A (MD RAFIKUL ISLAM)**

Floor Name	Total Built up Area (Sq.m)	Proposed Floor Area (Sq.m)	Total Floor Area (Sq.m)	Threat (No.)
Ground Floor	55.89	55.89	55.89	01
First Floor	55.89	55.89	55.89	01
Terrace Floor	0.00	0.00	0.00	00
Total	111.78	111.78	111.78	01
Area of Building	1	111.78	111.78	01

**SCHEDULE OF JOINERY:**

BUILDING NAME	WAVE	LENGTH	HEIGHT	WKS
A/MD RAFIKUL ISLAM	02	0.78	2.13	04
A/MD RAFIKUL ISLAM	01	0.91	2.13	04
A/MD RAFIKUL ISLAM	0	1.07	2.13	03
Total	-	-	-	11

**SCHEDULE OF JOINERY:**

BUILDING NAME	WAVE	LENGTH	HEIGHT	WKS
A/MD RAFIKUL ISLAM	02	0.80	1.00	02
A/MD RAFIKUL ISLAM	02	1.20	2.70	02
A/MD RAFIKUL ISLAM	02	1.20	2.70	02
A/MD RAFIKUL ISLAM	02	1.80	2.70	04
A/MD RAFIKUL ISLAM	02	1.80	2.70	02
Total	-	-	-	12

**UMBRELLA Table for Building 2A (MD RAFIKUL ISLAM)**

FLOOR	Name	UMBRELLA TYPE	UMBRELLA AREA	COVER AREA	No. of Rooms	No. of Tenement
GROUND FLOOR	SPLIT A	FLAT	78.17	78.35	5	1
Total	-	-	-	-	5	1

**PROJECT DETAILS:**

Project Name	MD RAFIKUL ISLAM
Client Name	MD ARIAD AIL
Project Location	VILLAGE - KODERMA, WARD NO-19, THANA NO - 333, DISTRICT - KODERMA, JHARKHAND
Project Type	Residential Building
Project Status	Approved
Project Date	2023-10-20

**AREA DETAILS:**

Area of Plot (sq.m)	111.78
Area of Building (sq.m)	111.78
Area of Terrace (sq.m)	0.00
Total Area (sq.m)	111.78

**PERMITS:**

Building Plan	111.78
Structural Plan	111.78
Electrical Plan	111.78
Water Supply Plan	111.78
Sanitary Plan	111.78
Fire Safety Plan	111.78
Other Plans	111.78

**DEVELOPMENT AUTHORITY:**

Authority Name	KODERMA DISTRICT MUNICIPAL CORPORATION
Authority Address	KODERMA, JHARKHAND
Authority Contact	0354-2611111

**COLOR INDEX:**

Plot Boundary	Red
Building Footprint	Blue
Structural Footprint	Green
Other Footprint	Yellow

**PARKING CALCULATION:**

Building Type	Residential	1	1
Plot Area (sq.m)	111.78	111.78	111.78
Total Parking	1	1	1

**MARGIN DETAIL:**

Building Name	MD RAFIKUL ISLAM	Front Length	Side Length	Back Length
Plot No.	942	2.82	1.51	0.90
Plot Area (sq.m)	111.78	111.78	111.78	111.78

**Building Info:**

Building Name	MD RAFIKUL ISLAM
Plot No.	942
Plot Area (sq.m)	111.78

**Plot Info:**

Plot No.	942
Plot Area (sq.m)	111.78

**FR & T Treatment Details (Table 4a-1)**

Building Name	MD RAFIKUL ISLAM	FR & T Treatment	1
Plot No.	942	FR & T Treatment	1
Plot Area (sq.m)	111.78	FR & T Treatment	1

**Building Name:** MD RAFIKUL ISLAM

**Plot No.:** 942

**Plot Area (sq.m):** 111.78

**FR & T Treatment Details (Table 4a-1)**

**Building Name:** MD RAFIKUL ISLAM

**Plot No.:** 942

**Plot Area (sq.m):** 111.78

**FR & T Treatment Details (Table 4a-1)**

**Building Name:** MD RAFIKUL ISLAM

**Plot No.:** 942

**Plot Area (sq.m):** 111.78

**FR & T Treatment Details (Table 4a-1)**