

Project Title :AKLEMA BIBI

AREA STATEMENT PARKUR WAGAR PARISHAD VERSION NO. 1.0.37
VERSION DATE: 16/10/2020

PROJECT DETAIL	
Project No.:	Plot Use Residential
Region :	JHARKHAND URBAN LOCAL BODIES
District :	PURBI DIVISION Other Residential Building
Application Type :	General Proposal
Project Type :	Building Permission
Nature of Development :	New
Location :	Old Area
Size Location :	NA
Ward No.:	North
Road/Street :	South
	East
	West

AREA DETAILS		UNIT	SQ.MT
Net Plot Area (Gross Plot Area)	(A) Deductions		324.37
Deduction from Gross Plot Area			
Deduction for Balance Plot Area (from Gross Plot Area)			
COF Area			65.58
Balance Plot Area (Net Plot Area - Recreational/Amenity space)	(A) Deductions		65.58
Plot Area for Coverage (Net FSI Area)	(A) Deductions		259.29
Plot Area for FSI (Net Plot Area + Road/Margin Area)	(A) Deductions		324.37
Coverage Check			
Proposed Coverage Area (27.21 %)			88.26
Total Coverage Area (27.21 %)			88.26
FAR CHECK			
Proposed Area of FAR			261.59
Total Area of FAR			261.59
Best Top Area Check			
Total Proposed Building Area			349.45
ARCHT/ENGR'S SUPERVISOR (Regd)			OWNER
DEVELOPMENT AUTHORITY			LOCAL BODY

COLOR INDEX	
ABUTTING ROAD	Black
PROPOSED WORK (COVERAGE AREA)	Green
EXISTING (To be retained)	Blue
EXISTING (To be demolished)	Yellow

Color Index:

PARKING CALCULATION:

Parking Type	Prop. No.	Prop. Area
Car Parking	1	23.25
Other Parking	1	64.47
TOTAL AREA	2	76.97

MARGIN DETAIL:

Building / Wing Name	Road Name	Front Margin	Rear Margin	Side1 Margin	Side2 Margin
A1 (RESIDENTIAL)	7.62 mt. Wide Main Road	4.00	3.00	1.50	1.50

FAR & Tenement Details (Table 4c-1)

Building	No. of Same Bldg	Total Built Up Area (Sq.mt)	Deductions (Area in Sq.mt)		Proposed FAR Area (Sq.mt)	Add Area in FAR (Sq.mt)	Total FAR Area (Sq.mt)	Tenement (No.)
			LI	Parking				
A (RESIDENTIAL)	1	349.45	10.89	76.97	253.92	7.67	261.59	03
Grand Total	1	349.45	10.89	76.97	253.92	7.67	261.59	03

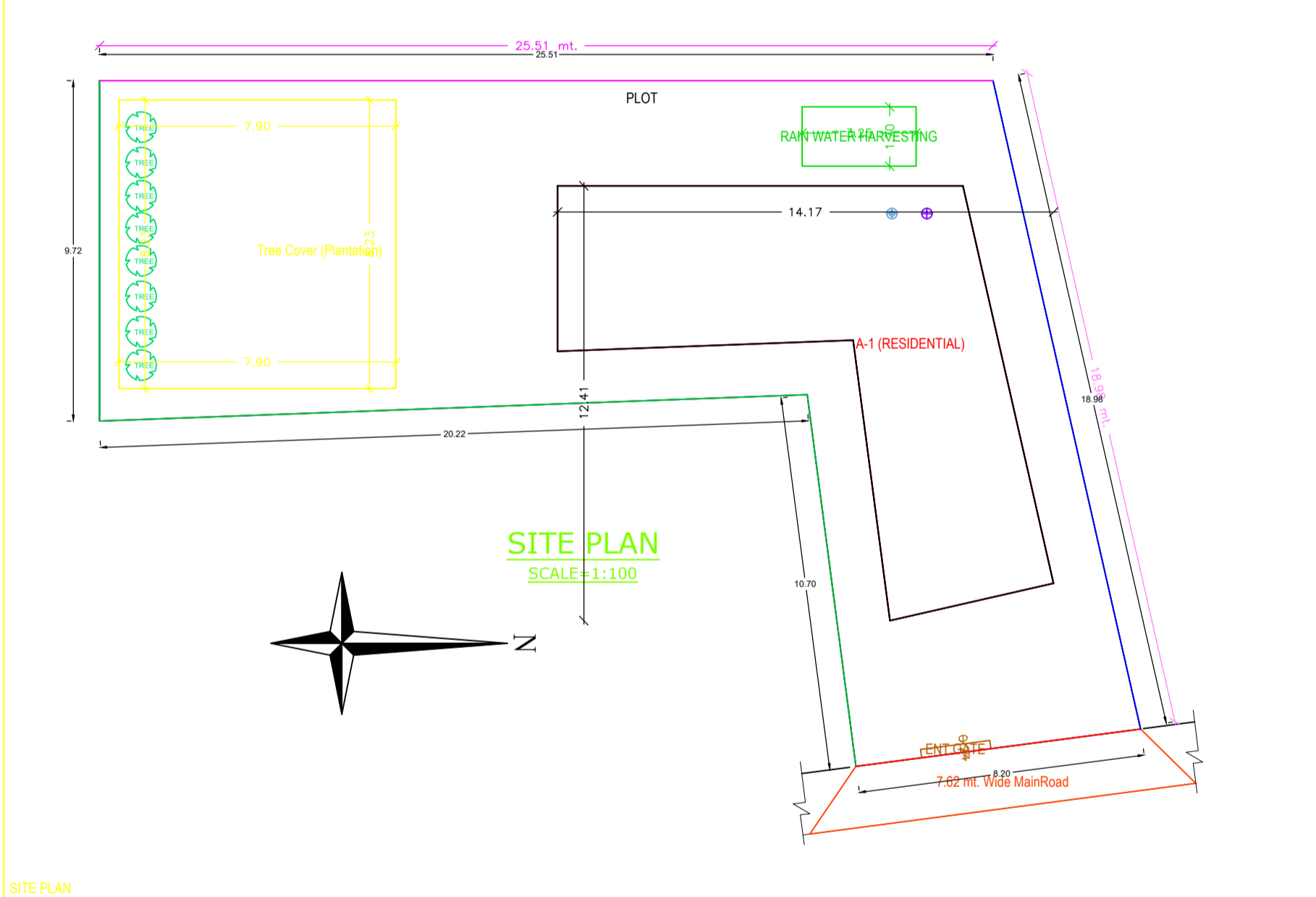
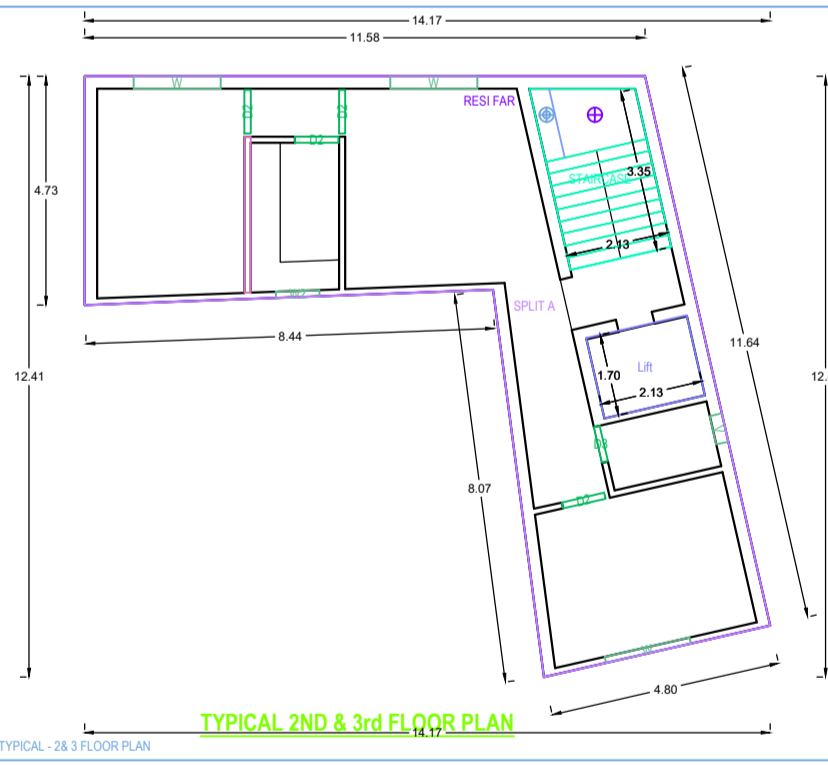
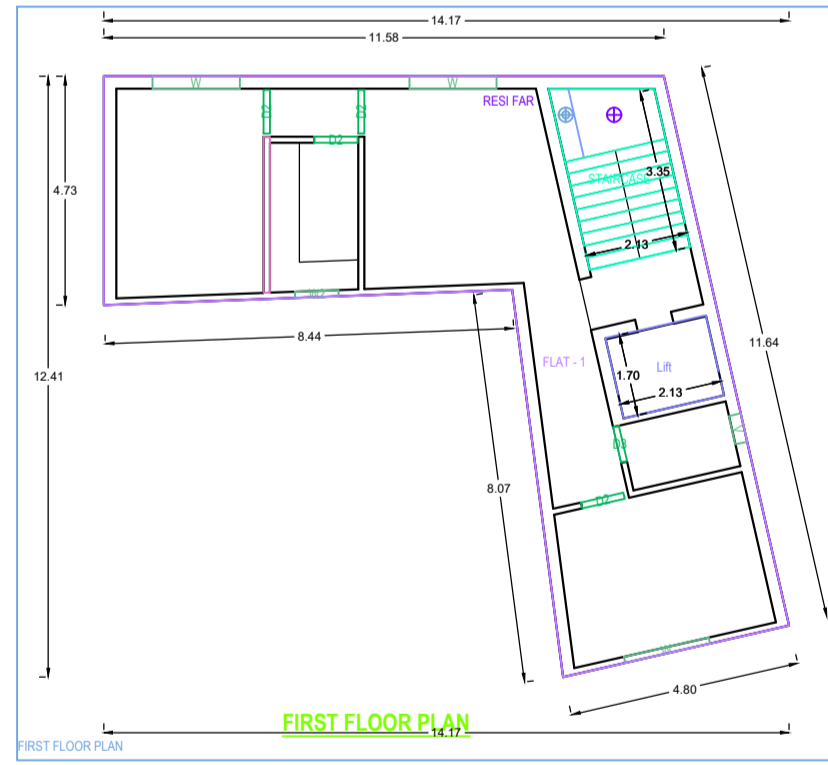
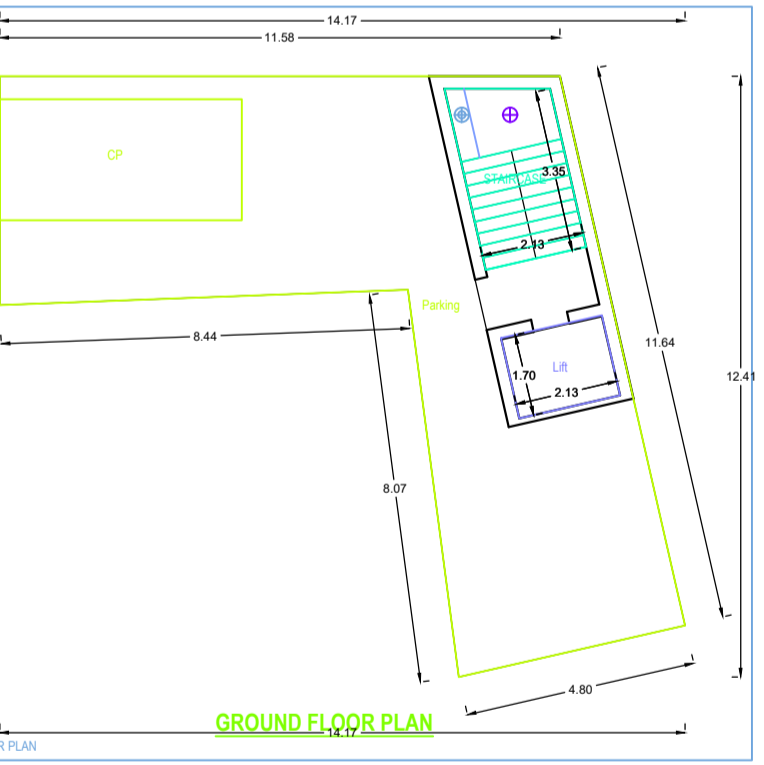
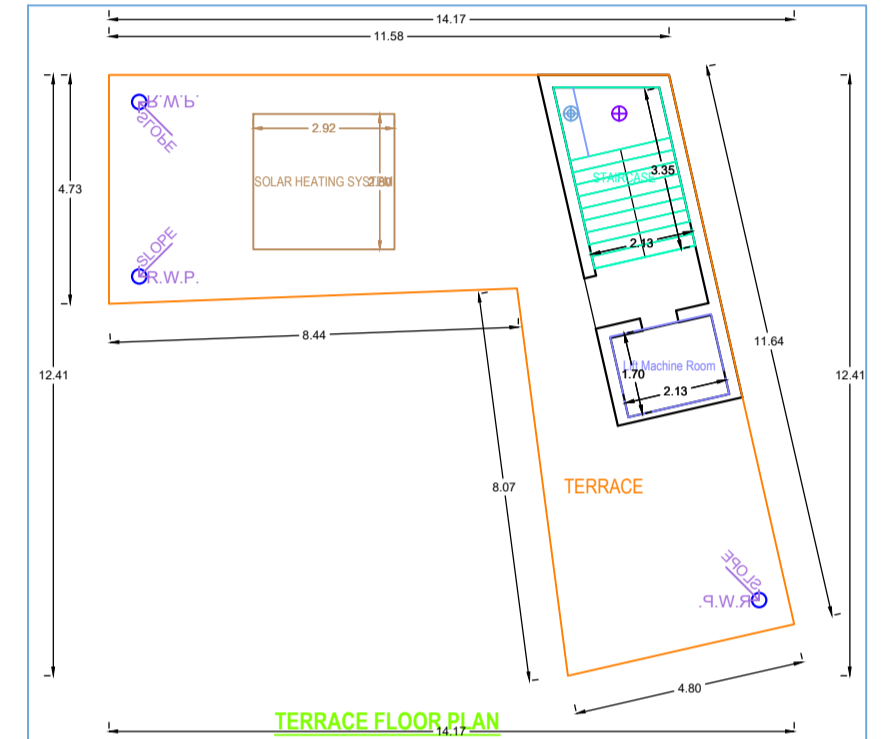
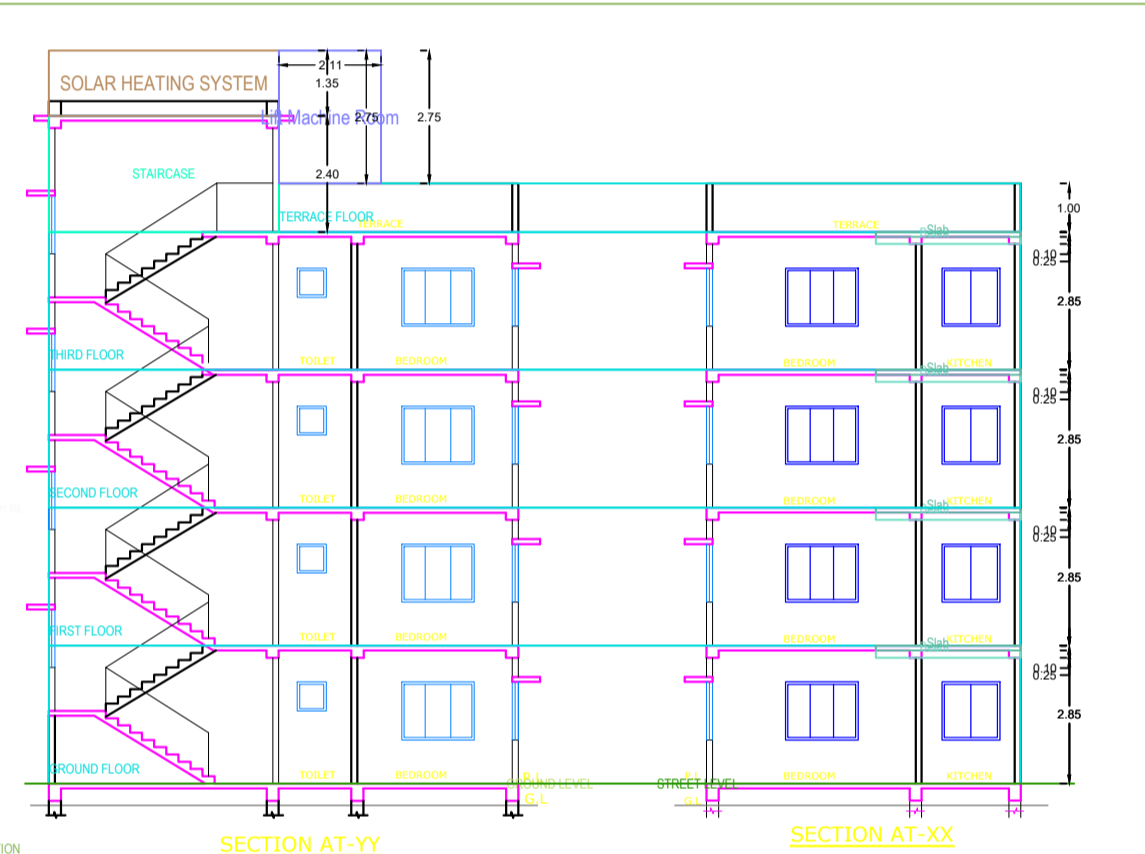
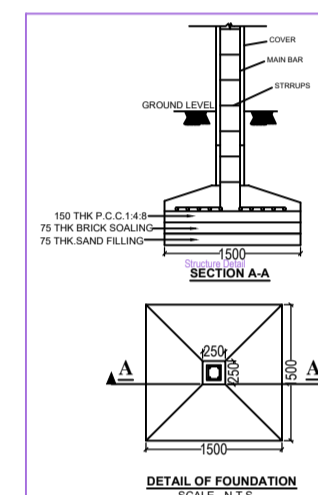
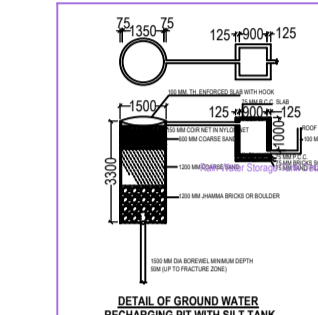
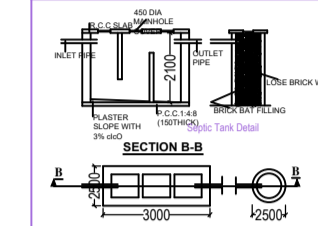

Building 'A' (RESIDENTIAL)

Floor Name	Total Built Up Area (Sq.mt)	Deductions (Area in Sq.mt)		Proposed FAR Area (Sq.mt)	Add Area in FAR (Sq.mt)	Total FAR Area (Sq.mt)	Tenement (No.)
		LI	Parking				
Ground Floor	84.64	0.00	76.97	0.00	7.67	7.67	00
First Floor	86.27	3.63	0.00	84.64	0.00	84.64	01
Second Floor	86.27	3.63	0.00	84.64	0.00	84.64	01
Third Floor	86.27	3.63	0.00	84.64	0.00	84.64	01
Terrace Floor	0.00	0.00	0.00	0.00	0.00	0.00	00
Total	349.45	10.89	76.97	253.92	7.67	261.59	03

SCHEDULE OF JOINERY:

BUILDING NAME	NAME	LENGTH	HEIGHT	NOS
A (RESIDENTIAL)	G3	0.75	2.10	03
A (RESIDENTIAL)	G2	0.90	2.10	12
Total	-	-	-	15

SCHEDULE OF JOINERY:

BUILDING NAME	NAME	LENGTH	HEIGHT	NOS
A (RESIDENTIAL)	V	0.90	1.90	03
A (RESIDENTIAL)	W2	0.90	1.20	03
A (RESIDENTIAL)	W	1.80	1.20	03
Total	-	-	-	09

UnitBUA Table for Building 'A' (RESIDENTIAL)

FLOOR	Name	URBUA Type	URBUA Area	Colof Area	No. of Rooms	No. of Tenement
FIRST FLOOR PLAN	FLAT - 1	FLAT	84.64	84.23	5	1
TYPICAL 2nd & 3rd FLOOR PLAN	FLAT - A	FLAT	84.64	84.23	5	2
Total	-	-	253.92	252.69	15	3