

Project Title: MANJU UPADHAY

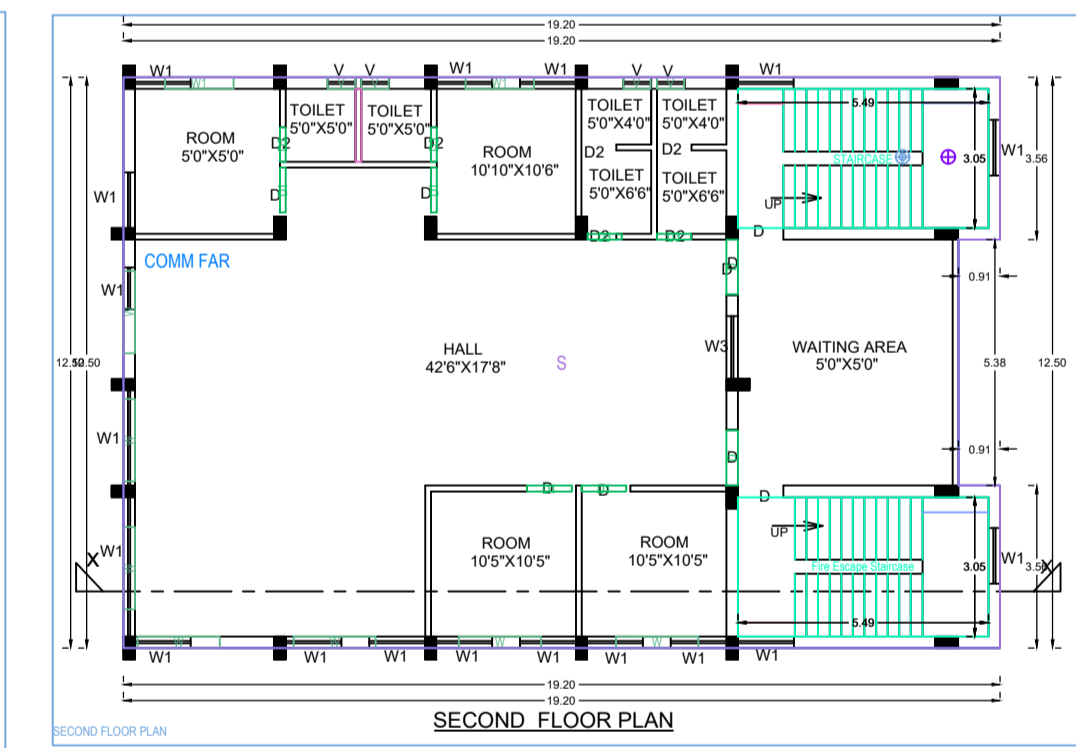
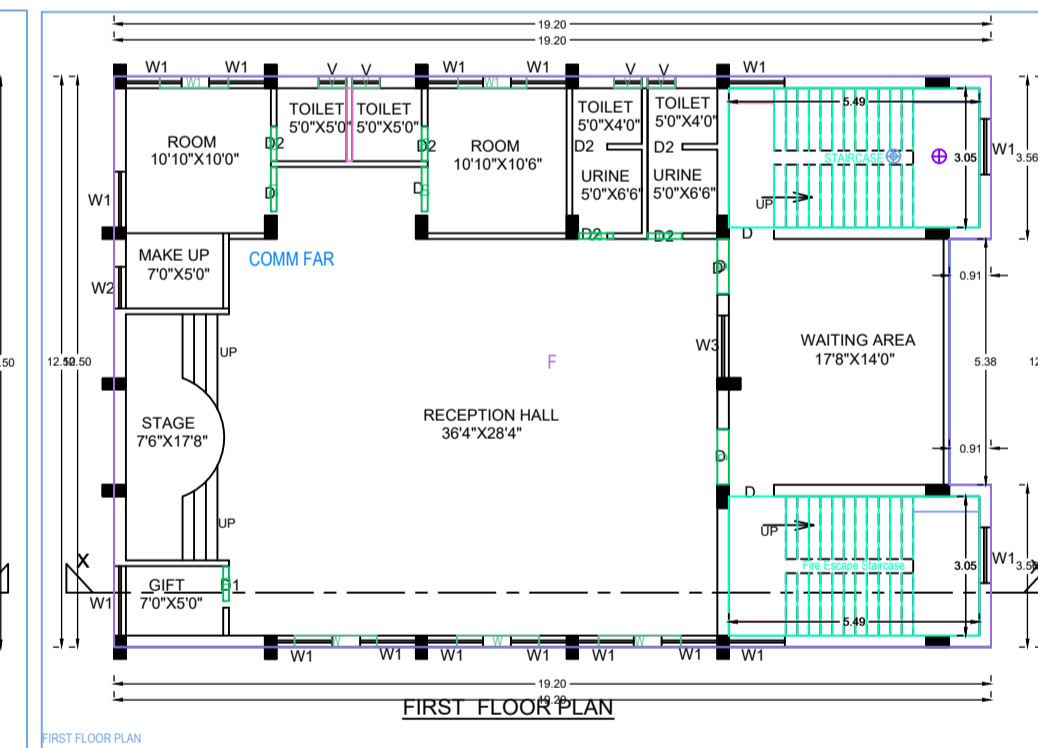
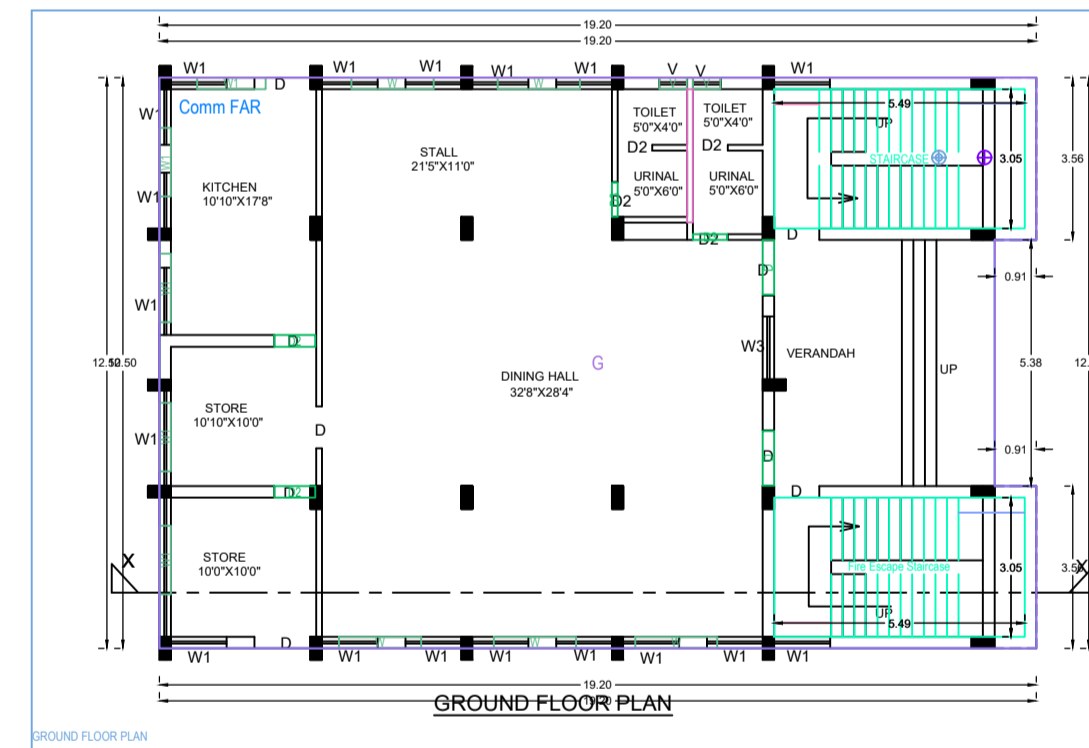
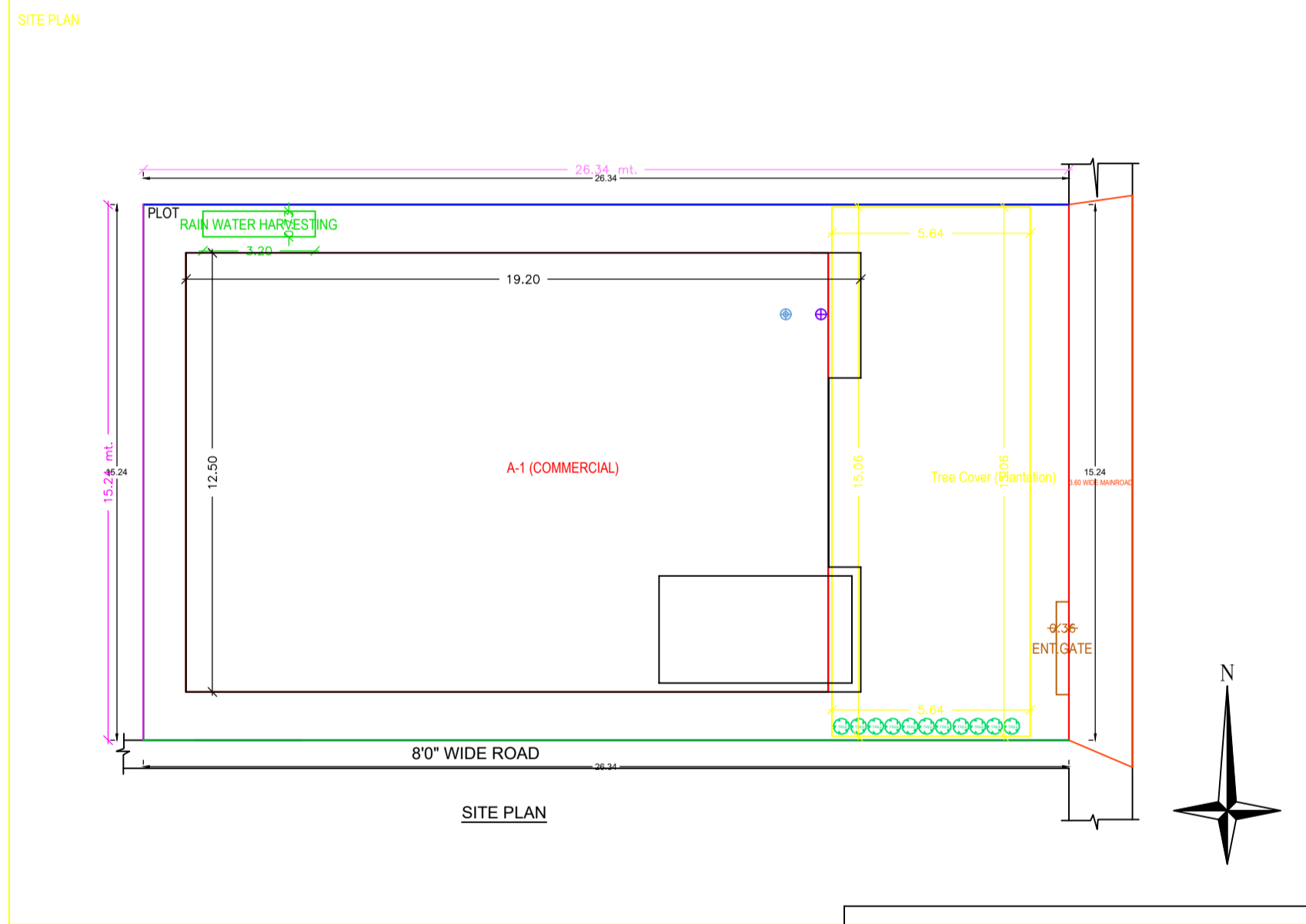
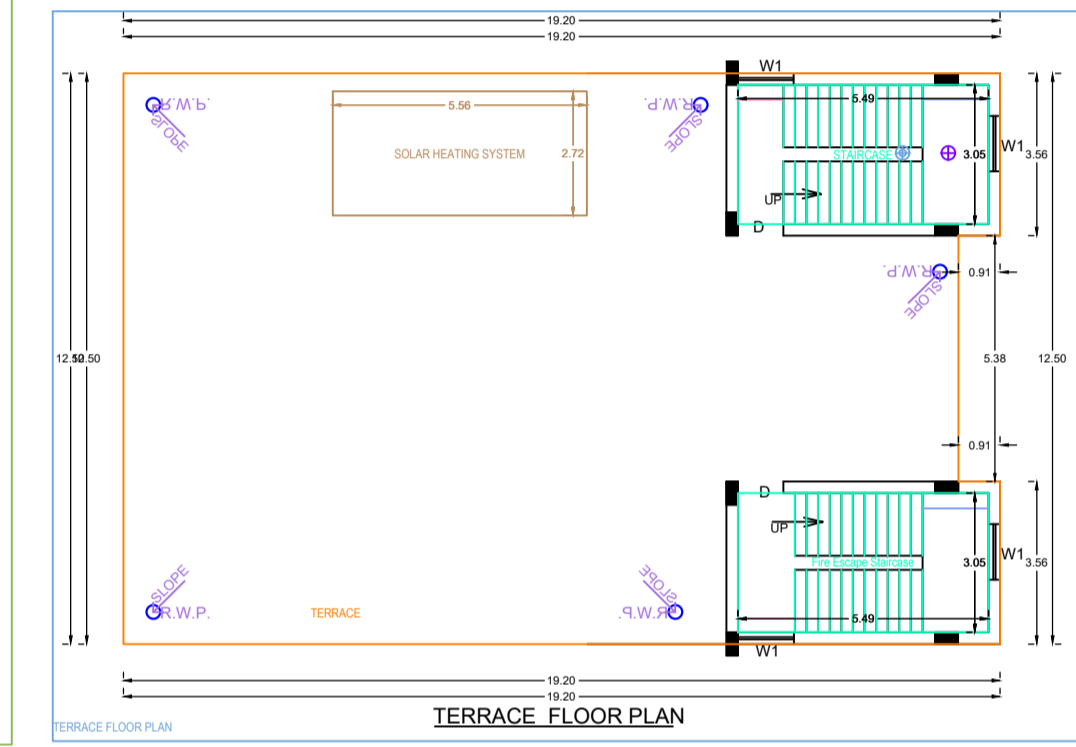
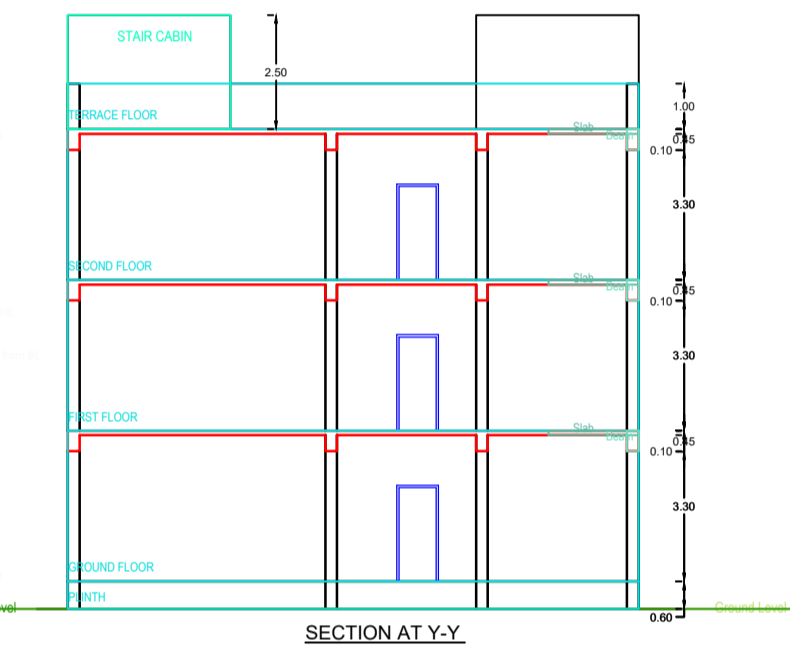
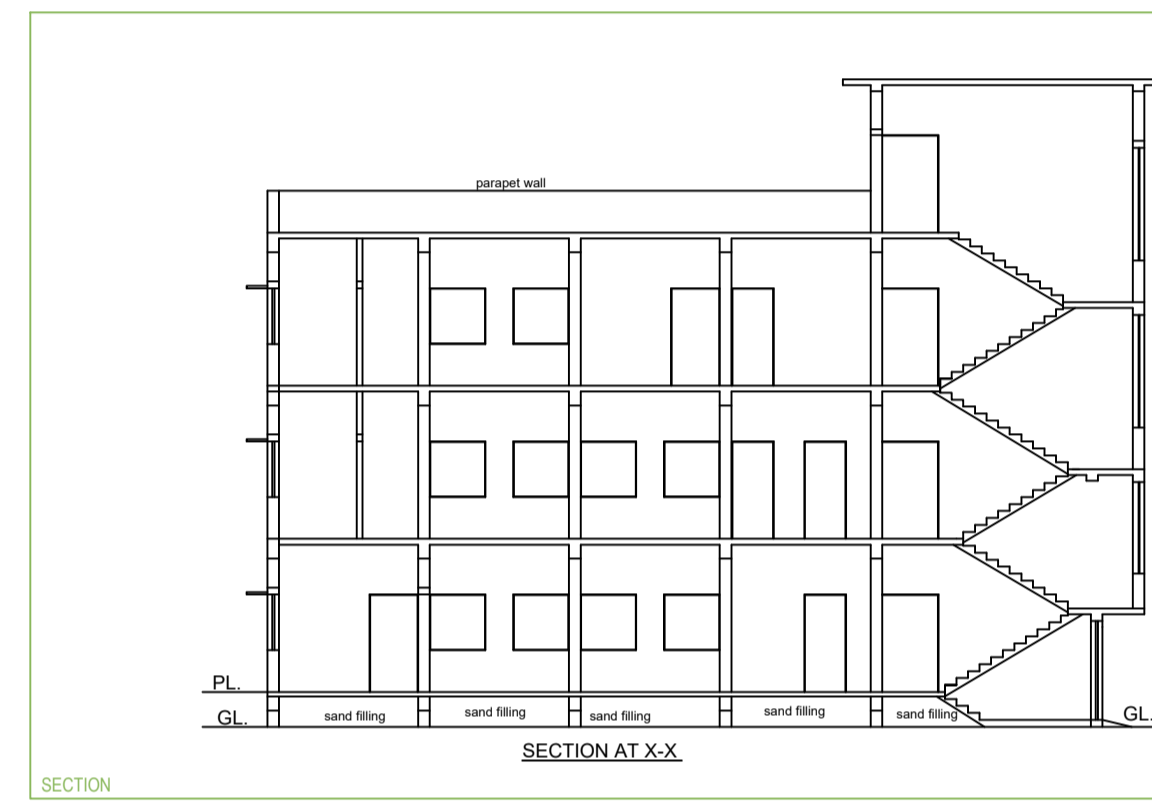
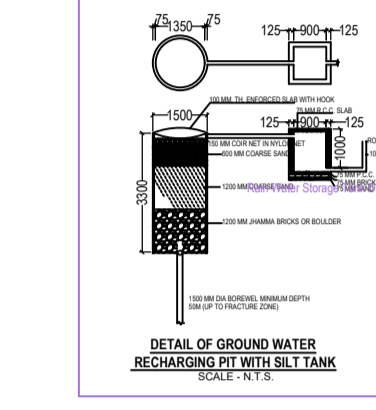
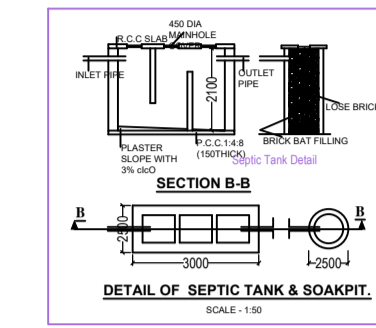
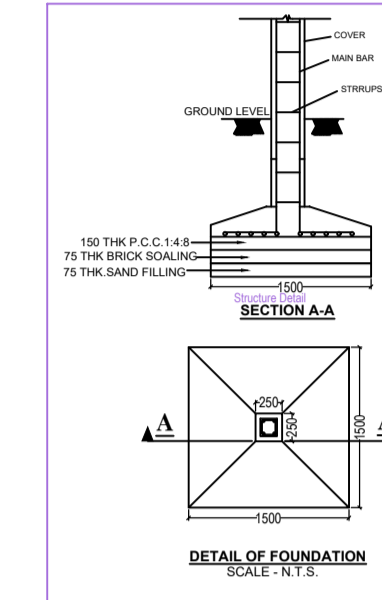
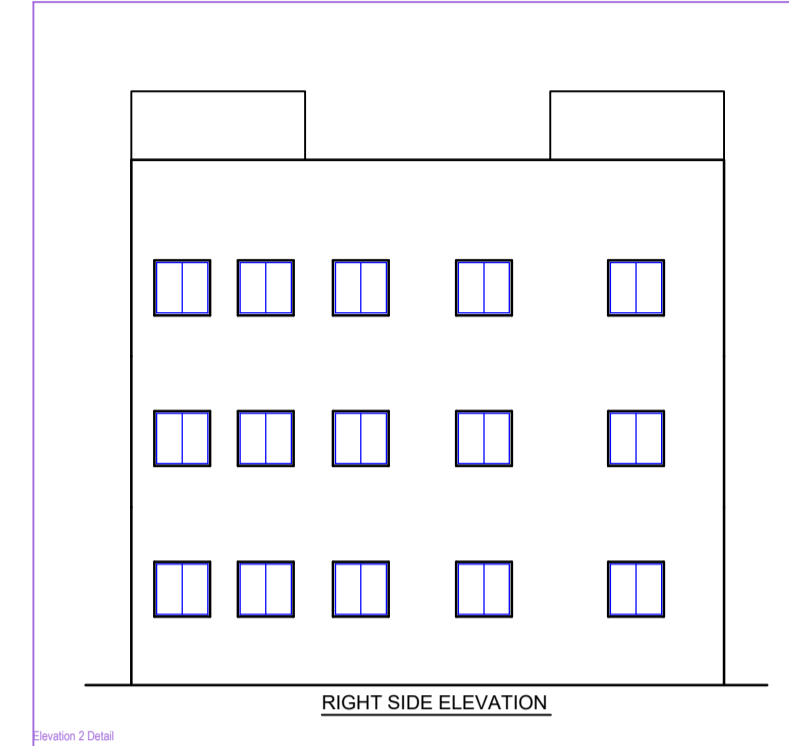
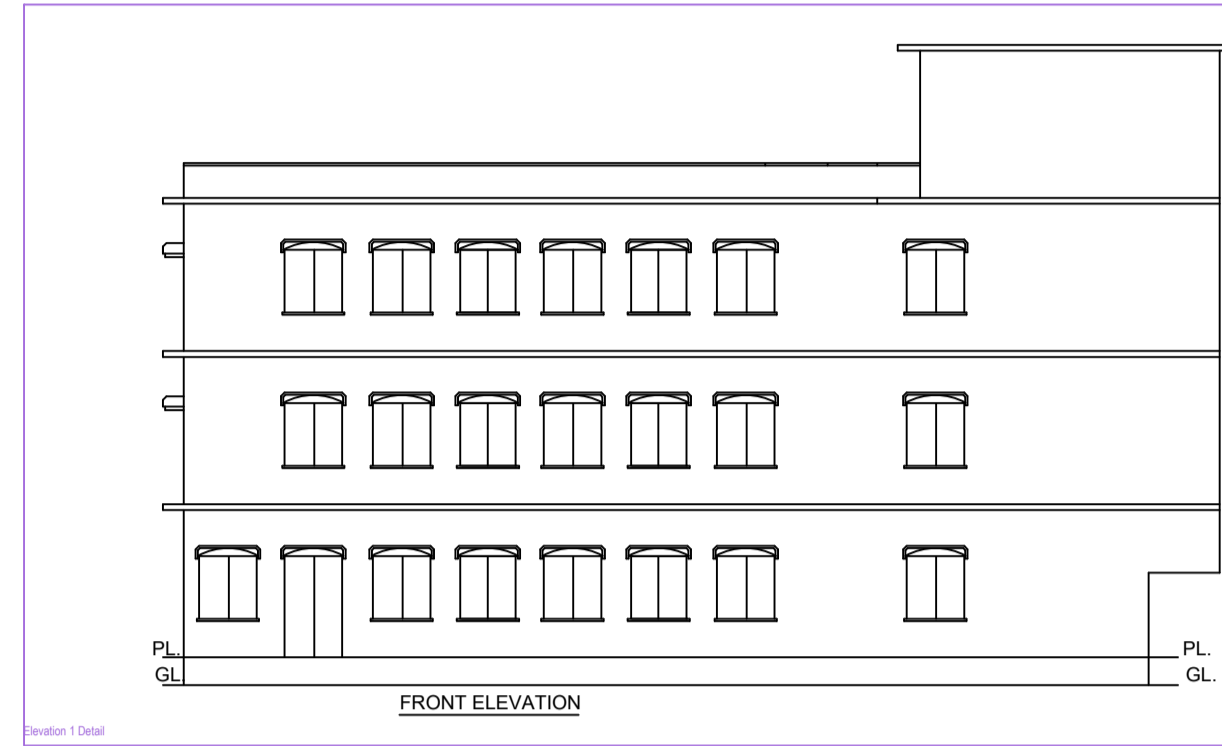

AREA STATEMENT: PAKUR SARAN PRASHNO

PROJECT DETAIL:

Project No.:	Plot No.:	Commercial
Region: JHARKHAND URBAN LOCAL BODIES	Plot Subdiv.:	Commercial Bldg.
District: PAKUR	Land Use Zone No.:	
Approval Type: General Proposal	Activity: Retail Shop:	
Project Type: Building Permission	Plot No.:	
Name of Development: New	Revenue Survey No./Subdiv. No.:	
Location: GFA Area	Thana No.:	
Site Location: NA	Planning No.:	
Ward/Area Name:	Choke No.:	
Ward No.:	South:	
Road Name:	East:	
	West:	

AREA DETAILS:

AREA OF PLOT (Minimum)	(A)	657.42
Net PLOT Area (Gross PLOT Area)	(A-Deductions)	401.42
Deduction from Gross PLOT Area		
Deduction for Retained PLOT Area from Gross PLOT Area		
COV Area		85.53
Net		85.53
Minimum PLOT Area (Net PLOT Area)	(A-Deductions)	316.39
PLOT Area for Coverage (Net PLOT Area)		401.42
PLOT Area for FSI (Net PLOT Area + Right of Way Area)	(A-Deductions)	401.42
COVERED CHECK		
Proposed Coverage Area (54.38 %)		218.32
Net Coverage Area (54.38 %)		218.32
Proposed Area of FAR		654.96
Total Area of FAR		654.96
BUILD UP AREA CHECK		
Net Proposed Build Up Area		705.12
RIGHT HEIGHT/SUPERSTORY CHECK		
DEVELOPMENT AUTHORITY		LOCAL BODY

COLOR INDEX:

PLUT BOUNDARY	Black
EXISTING ROAD	Red
PROPOSED WORK (COVERAGE AREA)	Green
EXISTING TO BE DEMOLISHED	Yellow
EXISTING TO BE DEMOLISHED	Orange

MARGIN DETAIL:

Building / Wing	Road Name	Front Margin	Rear Margin	Side1 Margin	Side2 Margin
A1 (COMMERCIAL)	MAINROAD	5.52	1.22	1.37	1.37

PAR & Tenement Details (Table 4c-1)

Building	No. of Same Bldg	Total Built Up Area (Sq.Mt)	Enclosures Area (Sq.Mt)	Proposed FAR Area (Sq.Mt)	Total FAR Area (Sq.Mt)
A (COMMERCIAL)	1	705.12	50.18	654.96	654.96
Grand Total:	1	705.12	50.18	654.96	654.96

Building A (COMMERCIAL)

Floor Name	Total Built Up Area (Sq.Mt)	Deductions (Area in Sq.Mt)	Proposed FAR Area (Sq.Mt)	Total FAR Area (Sq.Mt)
Ground Floor	235.04	16.72	218.32	218.32
First Floor	235.04	16.72	218.32	218.32
Second Floor	235.04	16.72	218.32	218.32
Terrace Floor	0.00	0.00	0.00	0.00
Total	705.12	50.16	654.96	654.96
Total Number of Same Building	1			
Total	705.12	50.16	654.96	654.96

SCHEDULE OF JOINERY:

BUILDING NAME	NAME	LENGTH	HEIGHT	NOS
A (COMMERCIAL)	D3	6.75	2.10	11
A (COMMERCIAL)	D2	0.90	2.10	02
A (COMMERCIAL)	D1	0.88	2.10	06
A (COMMERCIAL)	D	1.20	2.10	06
Total				25

SCHEDULE OF JOINERY:

BUILDING NAME	NAME	LENGTH	HEIGHT	NOS
A (COMMERCIAL)	V	0.60	1.50	10
A (COMMERCIAL)	W1	1.50	1.20	09
A (COMMERCIAL)	W	1.80	1.20	15
Total				34

UnitBIA Table for Building A (COMMERCIAL)

FLOOR	Name	UnitBIA Type	UnitBIA Area (Sq.Mt)	Carpet Area	No. of Rooms	No. of Tenement
GROUND FLOOR	G	SHOP	235.04	234.67	3	3
FIRST FLOOR	F	SHOP	235.04	234.64	3	1
SECOND FLOOR	S	SHOP	235.04	234.64	10	1
FLOOR PLAN			705.12	704.95	26	5