

Proposal Basic Information	
Proposal File No.	PNPC/BP/0010/W04/2024
Owner Name	SRI SURESH ROY
Khata No	304
Plot No	1340
Village Name	Pakur
Use	Residential
SubUse	Bungalow/ Dwelling / Non Apartment

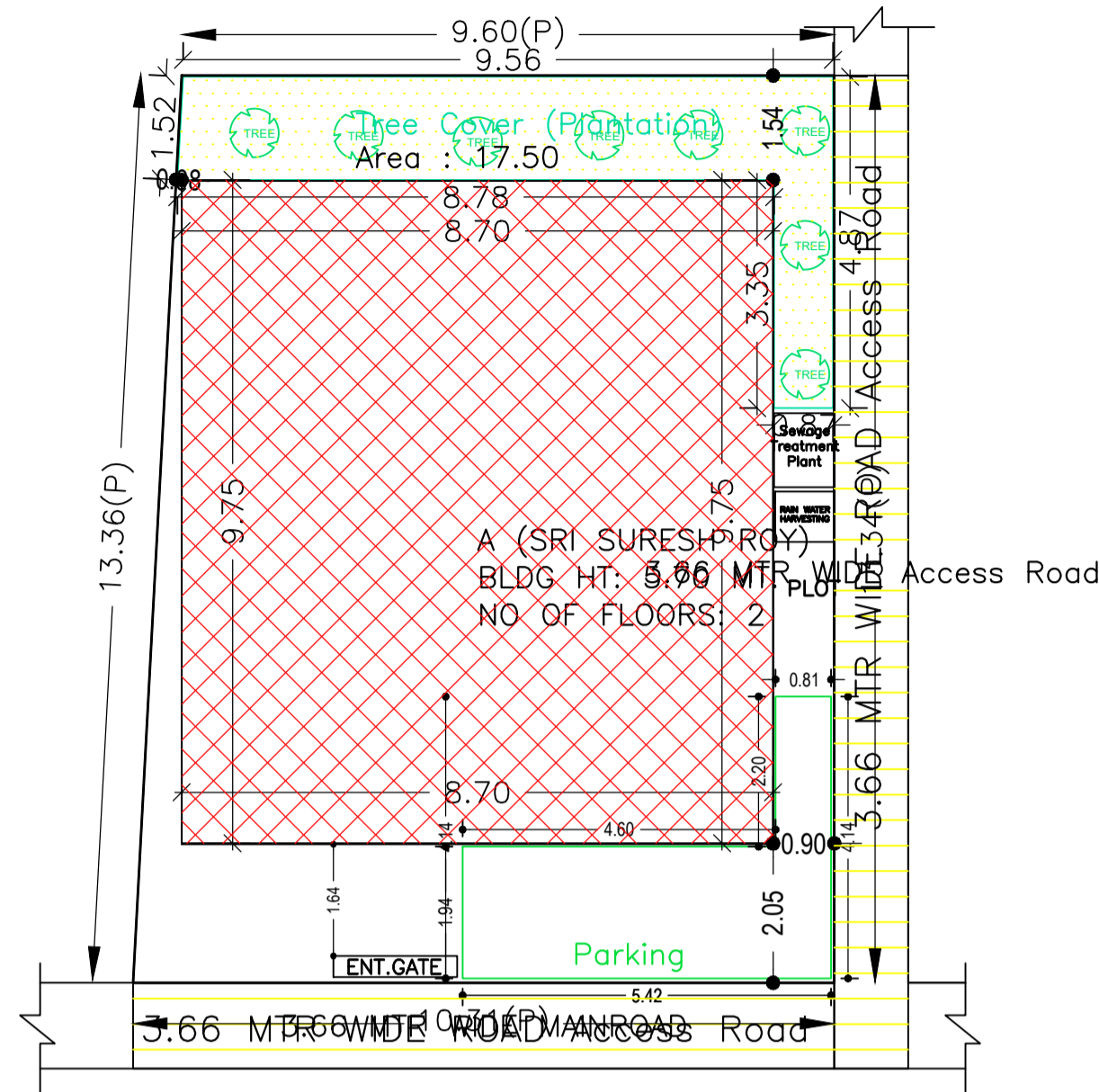

AREA STATEMENT PAKUR NAGAR PARISHAD		VERSION NO.: 1.0.68
		VERSION DATE: 16/10/2020
PROJECT DETAIL:		
Region: JHARKHAND URBAN	Plot Use: Residential	
LOCAL BODIES:		
District: PAKUR	Plot SubUse: Bungalow/ Dwelling / Non Apartment	
Authority: PAKUR NAGAR PARISHAD	PlotNearby/ReligiousStructure: NA	
Inward_No: PNP/0010/W04/2024	Plot/SubPlot No: 1340	
Application Type: General Proposal	North: Road Width - 3.66 MTR WIDE MAIN ROAD	
Project Type: Building Permission	South: -	
Nature of Development: New	East: -	
Location of Development Area: Old Area	West: -	
AREA DETAILS:		
AREA OF PLOT (Minimum)	(A)	132.82 SQ.MT.
NET AREA OF PLOT(Gross Plot Area - Deduction from Gross Plot area)	(A-Deductions)	132.82
Deduction for Balance Plot Area(from Gross Plot Area)		
Common Plot		17.50
Total		17.50
BALANCE AREA OF PLOT(Net Plot Area - Recreational/Amenity space)	(A-Deductions)	115.32
PLOT AREA FOR COVERAGE(Net Plot Area)	(A-Deductions)	132.82
Plot Area for FAR (Net Plot Area + RoadWidening Area)	(A-Deductions)	132.82
COVERAGE CHECK		
Permissible Coverage area (70.00 %)		92.97
Proposed Coverage Area (63.89 %)		84.86
Total Prop. Coverage Area (63.89 %)		84.86
Balance coverage area (6.11 %)		8.11
FAR CHECK		
Perm. FAR Area (1.500)		199.23
Total Perm. FAR area		199.23
Residential FAR		169.72
Proposed FAR Area		169.72
Total Proposed FAR Area		169.72
Consumed FAR (Factor)		1.28
Balance FAR Area		29.51
BUILT UP AREA CHECK		
Total Proposed BuiltUp Area		169.72
ARCHITECT (Regd)		KHUSHBU ANSARI
ENGINEER (Regd)		
SUPERVISOR (Regd)		
OWNER (Regd)		SRI SURESH ROY
DEVELOPMENT AUTHORITY		LOCAL BODY

COLOR INDEX	
PLOT BOUNDARY	Black
ABUTTING ROAD	Red
PROPOSED CONSTRUCTION	Green
COMMON PLOT	Yellow
ROAD WIDENING AREA	Blue
EXISTING (To be retained)	Light Blue
EXISTING (To be demolished)	Orange

Buildingwise Floor FAR Details

Floor Name	Building Name A (SRI SURESH ROY)		Total	
	Proposed Built Up Area (Sq.mt.)	Proposed FAR Area (Sq.mt.)	Total Proposed Built Up Area (Sq.mt.)	Total FAR Area (Sq.mt.)
Ground Floor	84.86	84.86	84.86	84.86
First Floor	84.86	84.86	84.86	84.86
Terrace Floor	0.00	0.00	0.00	0.00
Total :	169.72	169.72	169.72	169.72

Building USE/SUBUSE Details

Building Name	Building Use	Building SubUse	Building Structure
A (SRI SURESH ROY)	Residential	Bungalow/ Dwelling / Non Apartment	Non-Highrise

FAR & Tenement Details (Table 4c-1)

Building	No. of Same Bldg	Total Built Up Area (Sq.mt.)	Proposed FAR Area (Sq.mt.) Resi.	Total FAR Area (Sq.mt.)	Total Consumed Additional FAR Area (Sq.mt.)	Tnmt (No.)
A (SRI SURESH ROY)	1	169.72	169.72	169.72	169.72	01
Grand Total :	1	169.72	169.72	169.72	169.72	01

SITE PLAN

LTP NAME AND SIGNATURE	STRUCTURAL ENG'S NAME AND SIGNATURE	BUILDER NAME AND SIGNATURE	DIGITAL SIGNATURE
KHUSHBU ANSARI PNPC/ENG/0001/2024			

Proposal Basic Information	
Proposal File No.	PNPC/BP/0010/W04/2024
Owner Name	SRI SURESH ROY
Khata No	304
Plot No	1340
Village Name	Pakur
Use	Residential
SubUse	Bungalow/ Dwelling / Non Apartment

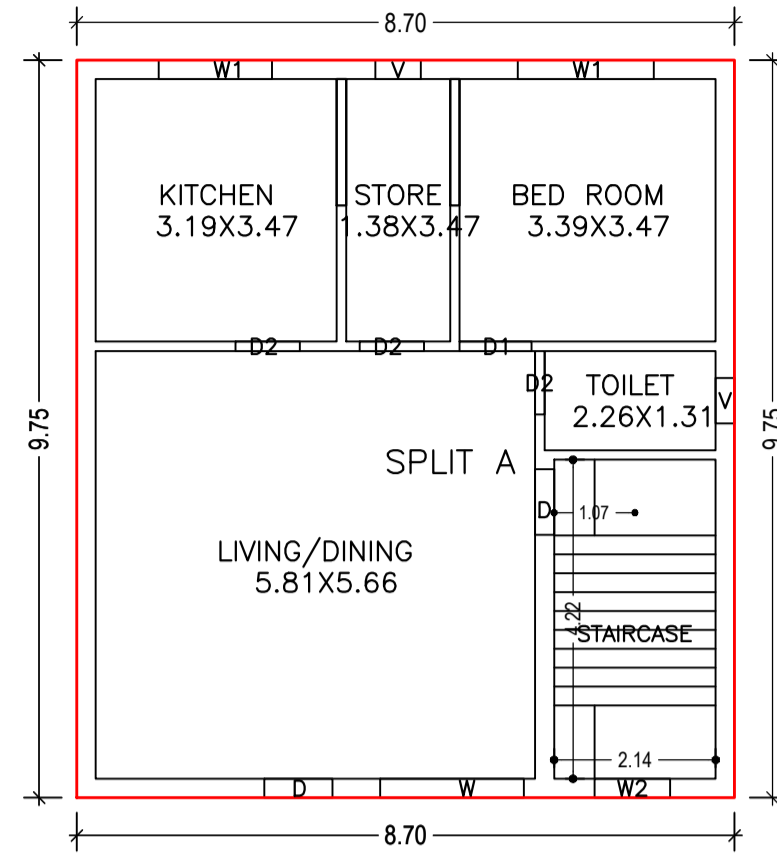

GROUND FLOOR PLAN (Proposed) (SCALE 1:100)

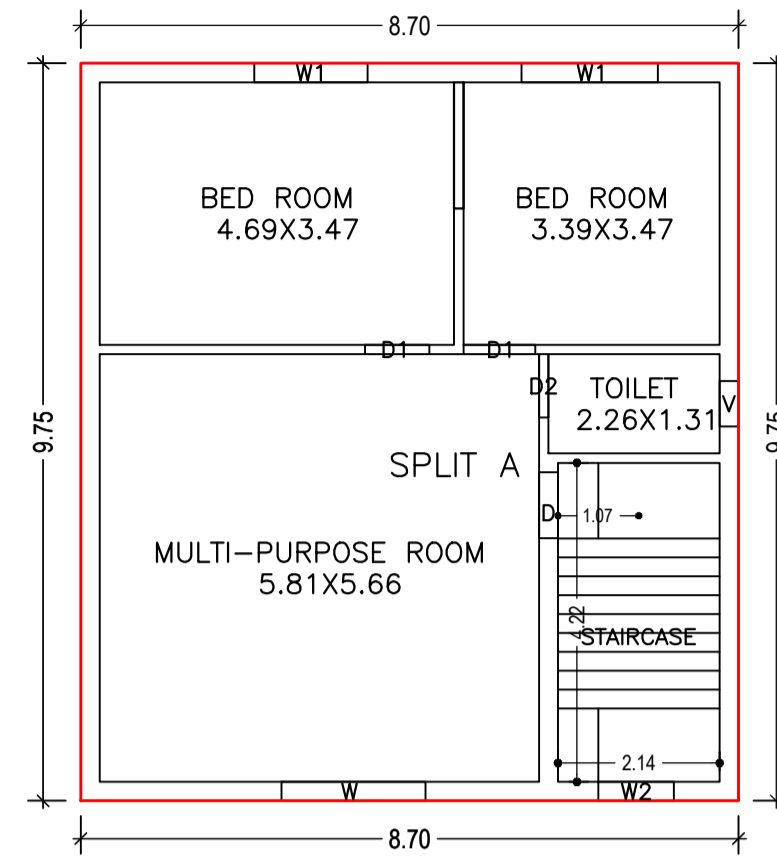

FIRST FLOOR PLAN (Proposed) (SCALE 1:100)

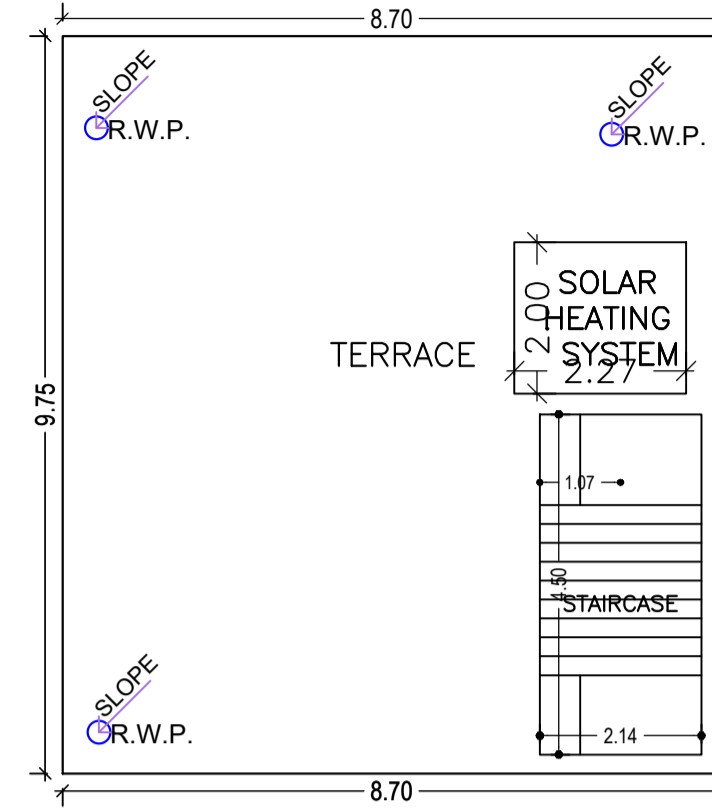

TERRACE FLOOR PLAN (SCALE 1:100)

Building :A (SRI SURESH ROY)

Floor Name	Total Built Up Area (Sq.mt.)	Proposed FAR Area (Sq.mt.)	Total FAR Area (Sq.mt.)	Total Consumed Additional FAR Area (Sq.mt.)	Trmt (No.)
Ground Floor	84.86	84.86	84.86	84.86	01
First Floor	84.86	84.86	84.86	84.86	00
Terrace Floor	0.00	0.00	0.00	0.00	00
Total :	169.72	169.72	169.72	169.72	01
Total Number of Same Buildings :	1				
Total :	169.72	169.72	169.72	169.72	01

SCHEDULE OF DOOR:

BUILDING NAME	NAME	LENGTH	HEIGHT	NOS
A (SRI SURESH ROY)	D2	0.84	2.13	02
A (SRI SURESH ROY)	D1	0.85	2.13	01
A (SRI SURESH ROY)	D2	0.85	2.13	02
A (SRI SURESH ROY)	D	0.87	2.13	02
A (SRI SURESH ROY)	D	0.90	2.13	01
A (SRI SURESH ROY)	D1	0.95	2.13	02

SCHEDULE OF WINDOW/VENTILATION:

BUILDING NAME	NAME	LENGTH	HEIGHT	NOS
A (SRI SURESH ROY)	V	0.60	2.00	03
A (SRI SURESH ROY)	W2	1.00	2.70	02
A (SRI SURESH ROY)	W1	1.50	2.70	02
A (SRI SURESH ROY)	W1	1.80	2.70	02
A (SRI SURESH ROY)	W	1.90	2.50	02

UnitBUA Table for Building :A (SRI SURESH ROY)

FLOOR	Name	UnitBUA Type	UnitBUA Area	Carpet Area	No. of Rooms	No. of Tenement
GROUND FLOOR PLAN	SPLIT A	FLAT	131.02	130.39	5	1
FIRST FLOOR PLAN	SPLIT A	FLAT	0.00	0.00	4	0
Total:	-	-	131.02	130.39	9	1

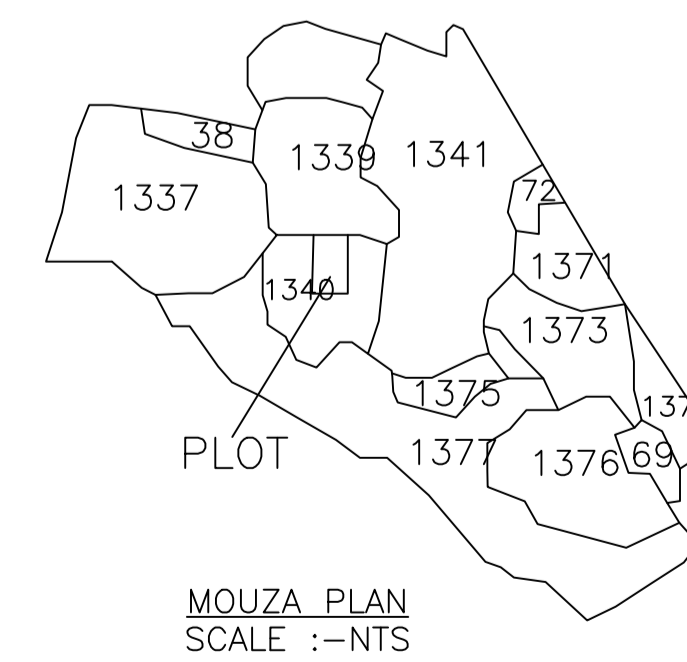
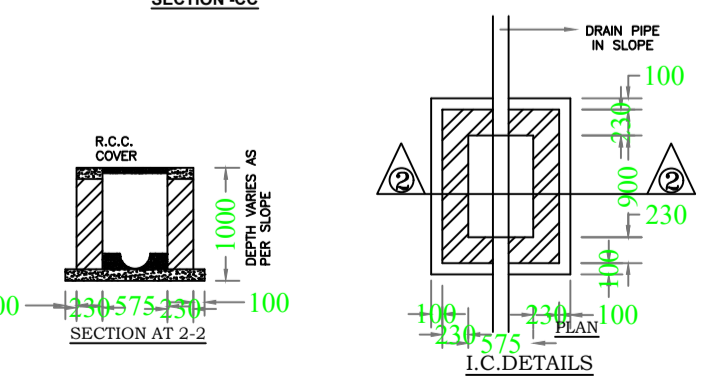
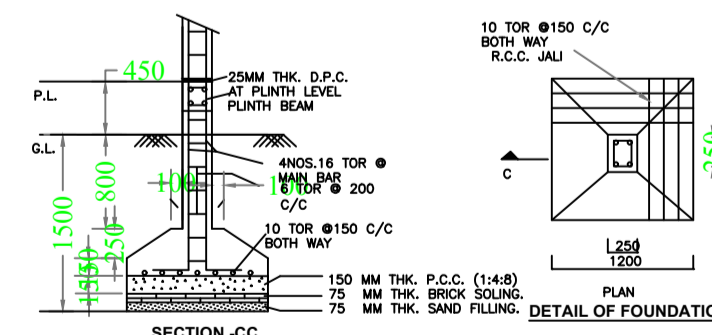
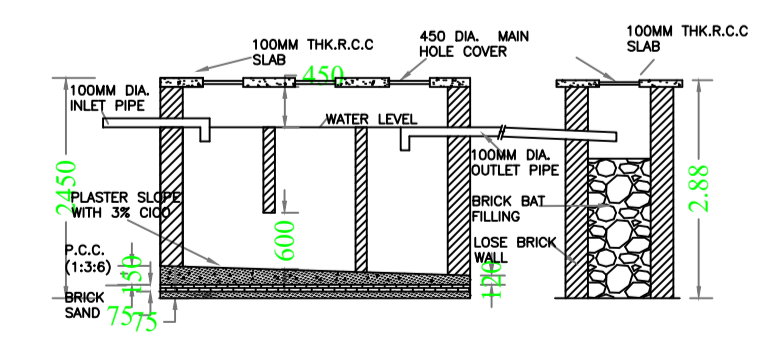
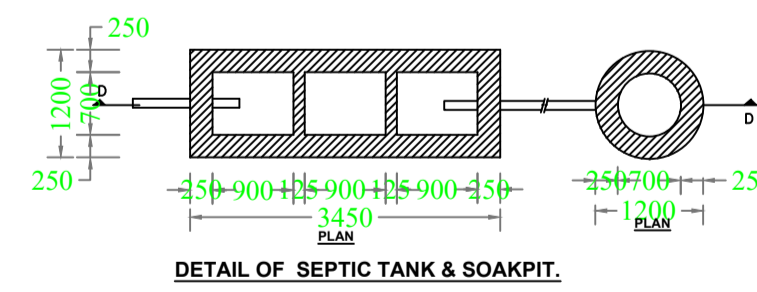
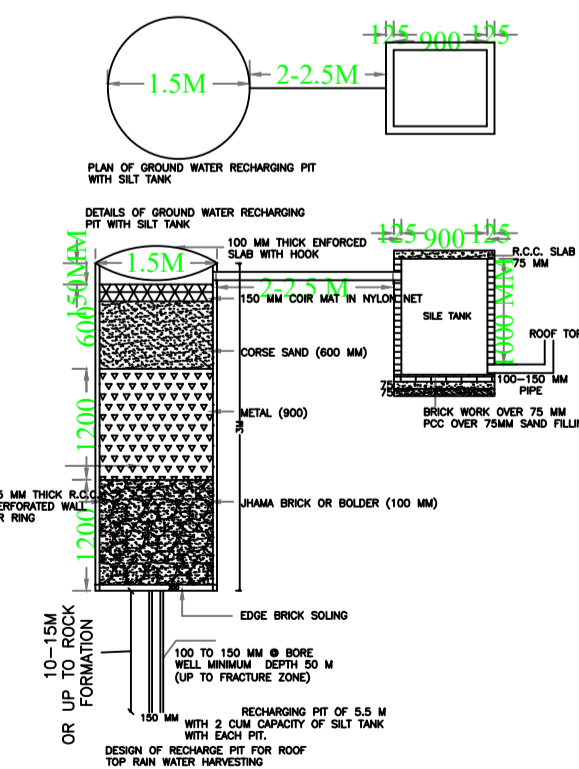
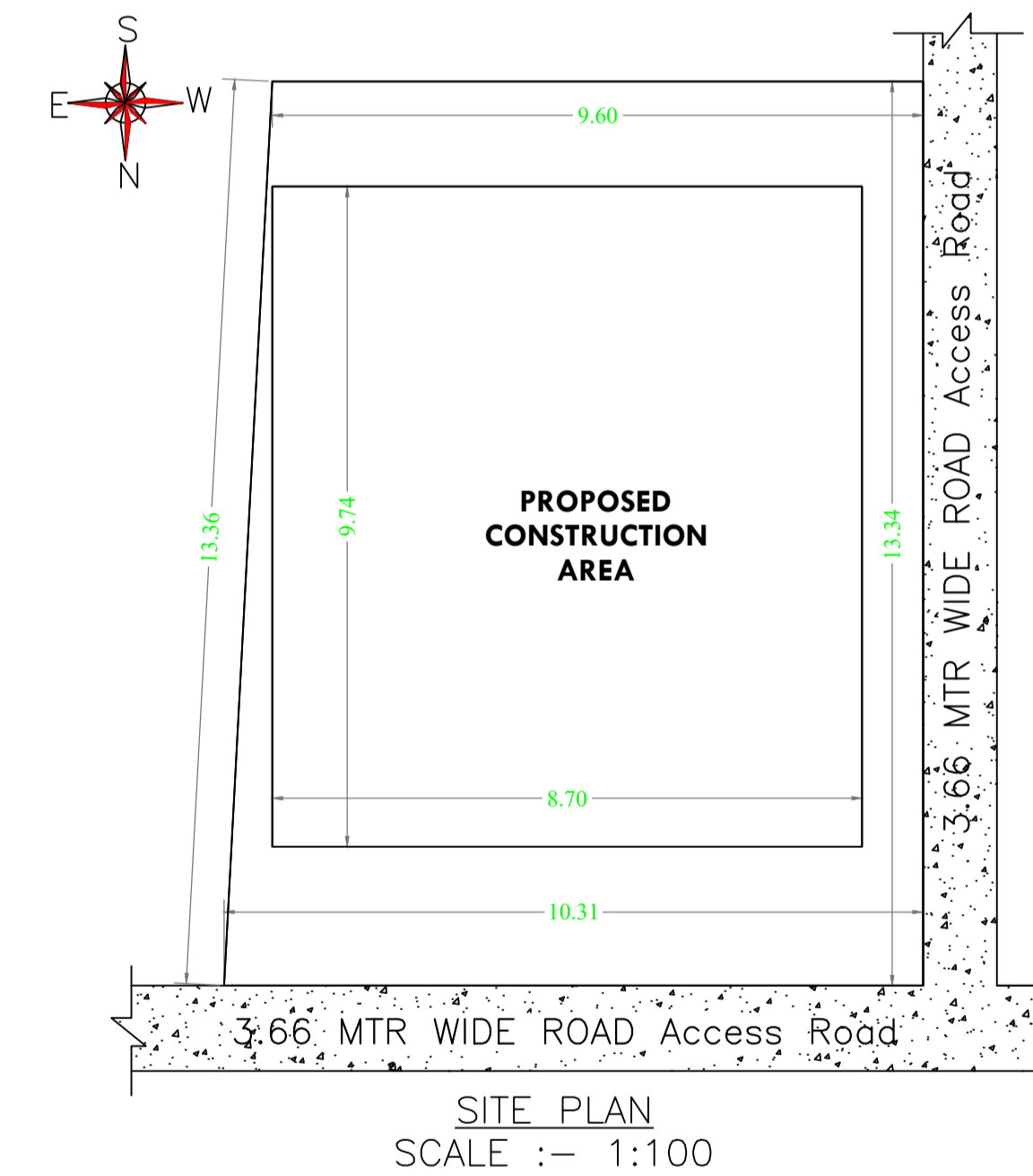
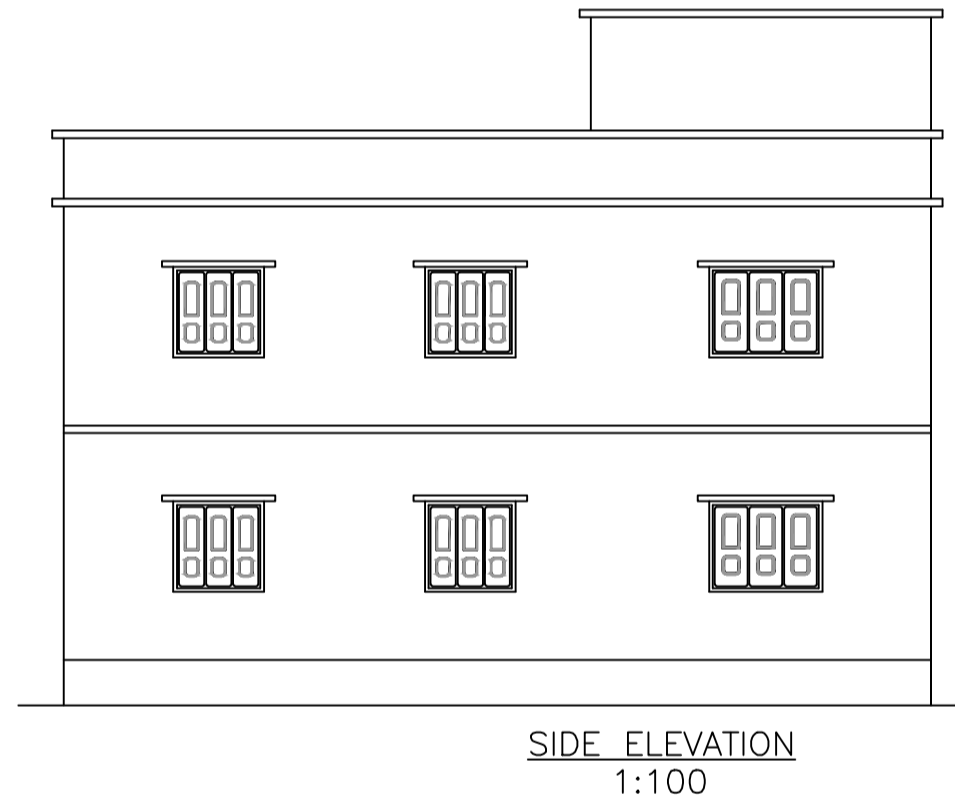
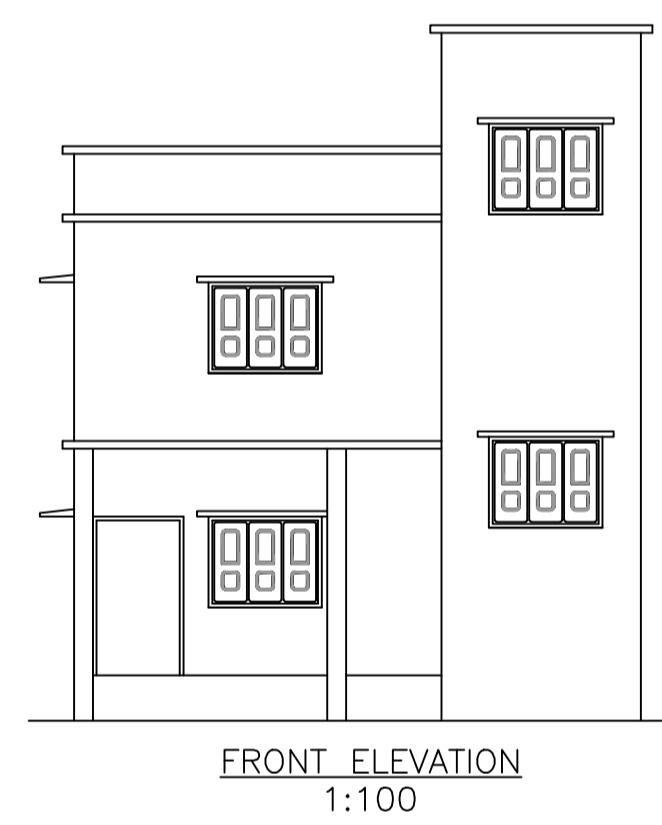
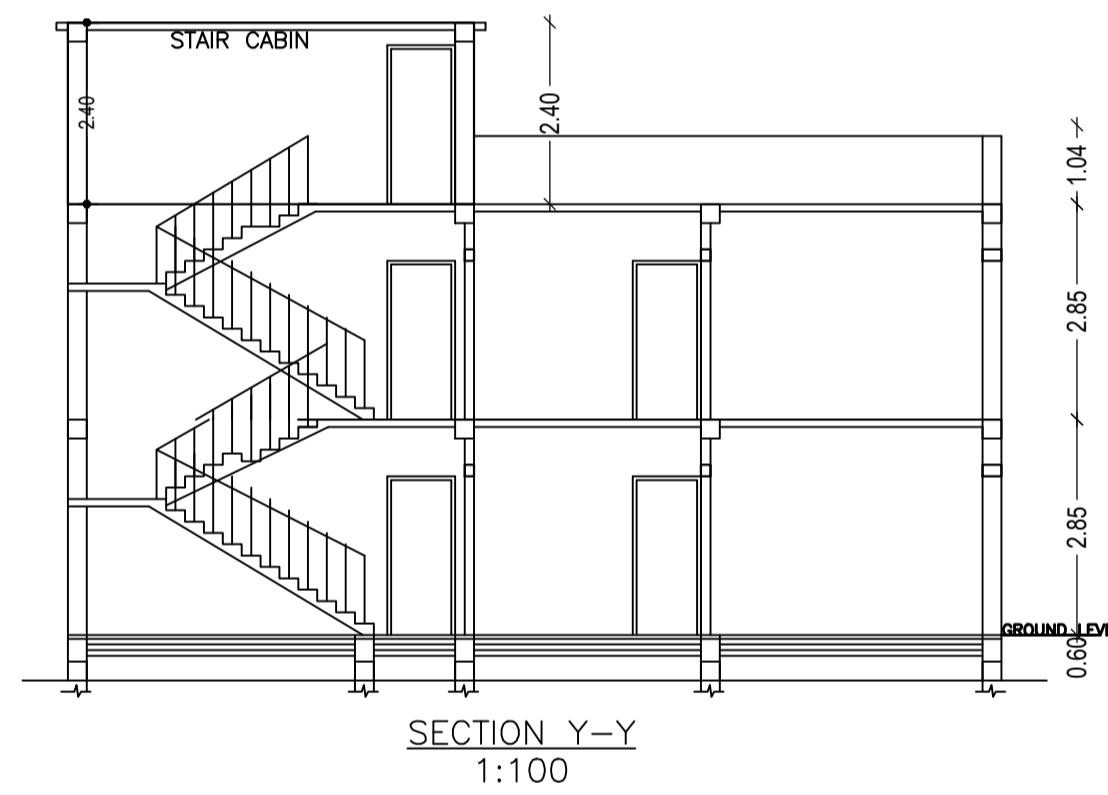
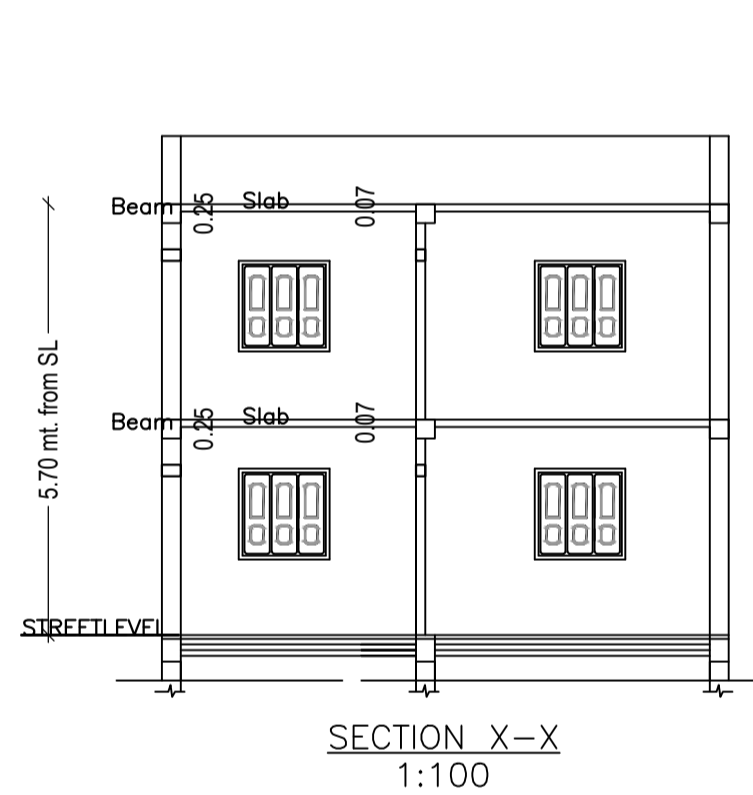

LTP NAME AND SIGNATURE	STRUCTURAL ENG'S NAME AND SIGNATURE	BUILDER NAME AND SIGNATURE	DIGITAL SIGNATURE
KHUSHBU ANSARI PNPC/ENG/0001/2024			