

SITE PLAN
SCALE : 1:100

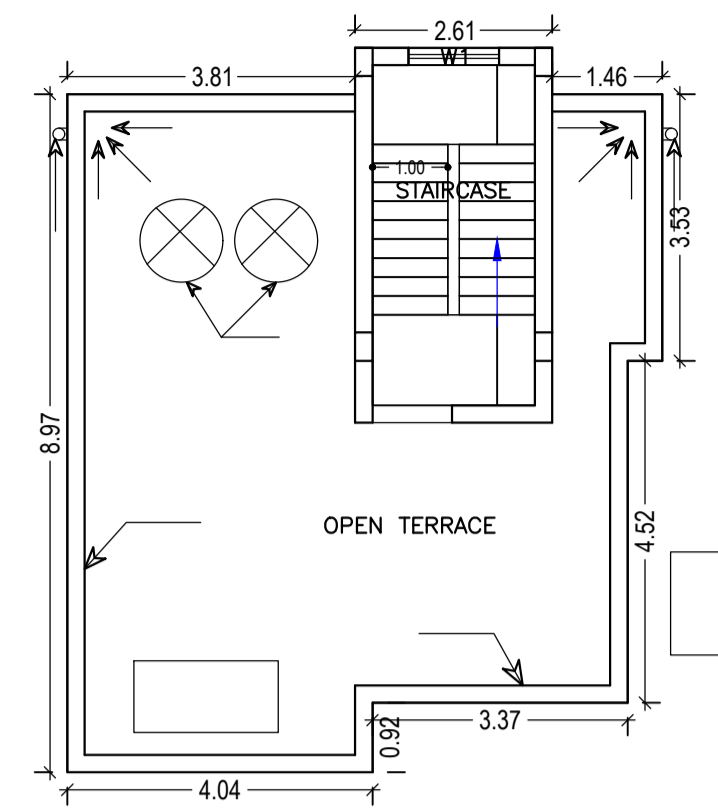

TERRACE FLOOR PLAN
(SCALE : 1:100)

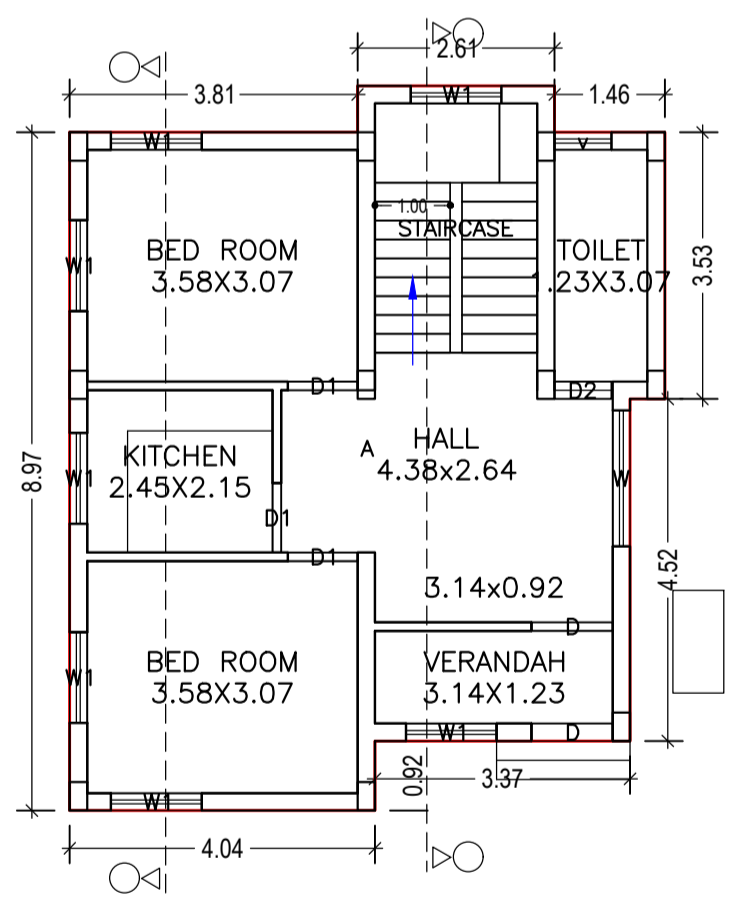

GROUND FLOOR PLAN
(Proposed)
(SCALE 1:100)

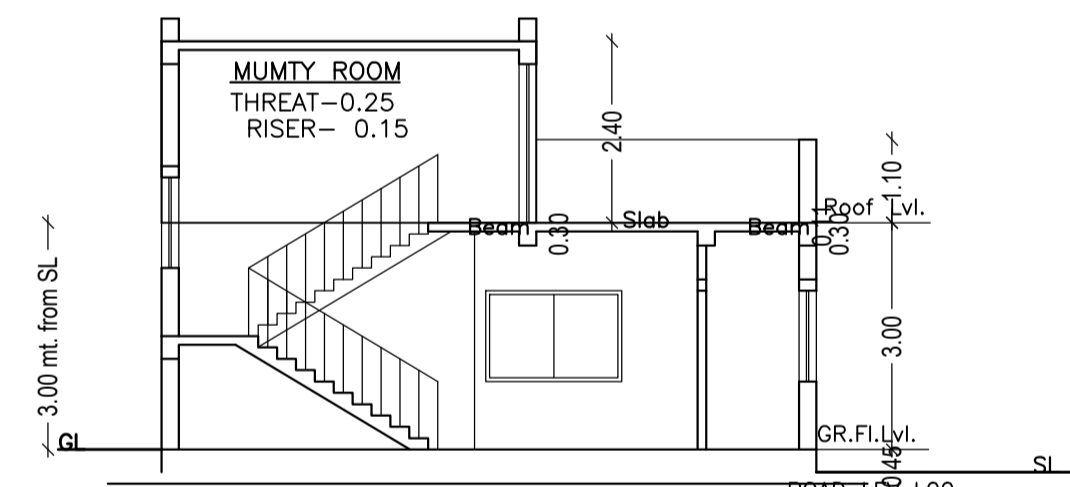

SECTION A-A
SCALE : 1:100

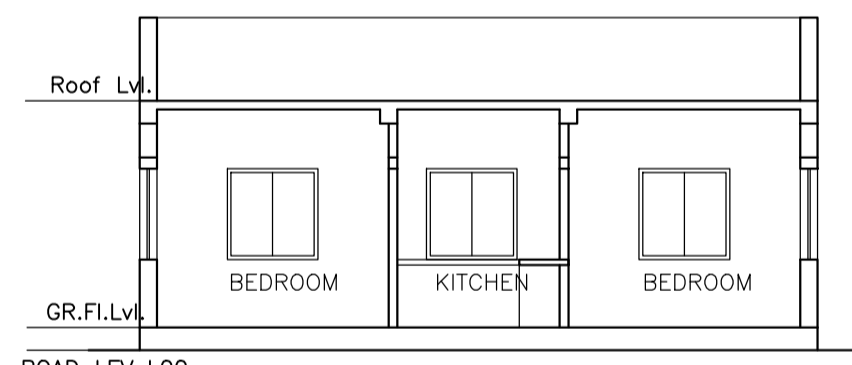

SCHEDULE OF DOOR:

BUILDING NAME	NAME	LENGTH	HEIGHT	NOS
A (SHYAMALI HANSDA)	D2	0.75	2.10	01
A (SHYAMALI HANSDA)	D1	0.92	2.10	03
A (SHYAMALI HANSDA)	D	1.07	2.10	02

SCHEDULE OF WINDOW/VENTILATION:

BUILDING NAME	NAME	LENGTH	HEIGHT	NOS
A (SHYAMALI HANSDA)	v	0.75	0.60	01
A (SHYAMALI HANSDA)	W1	1.20	1.20	08
A (SHYAMALI HANSDA)	W	1.80	1.20	01

UnitBUA Table for Building :A (SHYAMALI HANSDA)

FLOOR	Name	UnitBUA Type	UnitBUA Area	Carpet Area	No. of Rooms	No. of Tenement
GROUND FLOOR PLAN	A	FLAT	66.60	60.66	6	1
Total:	-	-	66.60	60.66	6	1

FAR & Tenement Details (Table 4c-1)

Building	No. of Same Bldg	Total Built Up Area (Sq.mt.)	Proposed FAR Area (Sq.mt.) Resi.	Total FAR Area (Sq.mt.)	Total Consumed Additional FAR Area (Sq.mt.)	Tnmt (No.)
A (SHYAMALI HANSDA)	1	66.60	66.60	66.60	66.60	01
Grand Total :	1	66.60	66.60	66.60	66.60	01

Proposal Basic Information

Proposal File No.	CNPC/BP/0015/ward8/2019
Owner Name	SMT. SHYAMALI HANSDA
Khata No	107
Plot No	275 part
Village Name	Kankrisole
Use	Residential
SubUse	Bungalow/ Dwelling / Non Apartment

AREA STATEMENT		VERSION NO. : 1.0.43
CHAKULIA NAGAR PANCHAYAT		VERSION DATE: 29/04/2019
PROJECT DETAIL:		
Region: JHARKHAND URBAN LOCAL BODIES	Plot Use: Residential	
District: EAST SINGHBHUM	Plot SubUse: Bungalow/ Dwelling / Non Apartment	
Authority: CHAKULIA NAGAR PANCHAYAT	PlotNearby/ReligiousStructure: NA	
Inward No: CNPC/BP/0015/ward8/2019	Plot/SubPlot No: 275 part	
Application Type: General Proposal	North: Survey No. - Sub plot no.-27	
Project Type: Building Permission	South: Survey No. - Sub plot no.-29	
Nature of Development: New	East: Road Width - 3.6	
Location of Development Area: Old Area	West: Survey No. - niz	
AREA DETAILS:		
AREA OF PLOT (Minimum)	(A)	201.82
Deduction for NetPlot Area		
Road Widening Area		7.77
Total		7.77
NET AREA OF PLOT(Gross Plot Area - Deduction from Gross Plot area)	(A-Deductions)	194.05
Deduction for Balance Plot Area(from Gross Plot Area)		
Road Widening Area		7.77
Common Plot		23.63
Total		31.41
BALANCE AREA OF PLOT(Net Plot Area - Recreational/Amenity space)	(A-Deductions)	170.42
PLOT AREA FOR COVERAGE(Net Plot Area)	(A-Deductions)	194.05
Plot Area for FAR (Net Plot Area + Road/Widening Area)	(A-Deductions)	194.05
COVERAGE CHECK		
Permissible Coverage area (70.00 %)		135.84
Proposed Coverage Area (34.32 %)		66.60
Total Prop. Coverage Area (34.32 %)		66.60
Balance coverage area (35.68 %)		69.24
FAR CHECK		
Perm. FAR Area (1.50)		291.08
Total Perm. FAR area		291.08
Residential FAR		66.60
Proposed FAR Area		66.60
Total Proposed FAR Area		66.60
Consumed FAR (Factor)		0.34
Balance FAR Area		224.48
BUILT UP AREA CHECK		
Total Proposed BuiltUp Area		66.60
ARCHITECT (Regd)	L K SUMAN	
ENGINEER (Regd)		
SUPERVISOR (Regd)		
OWNER (Regd)	SMT. SHYAMALI HANSDA	
DEVELOPMENT AUTHORITY		LOCAL BODY

COLOR INDEX	
PLOT BOUNDARY	Black
ABUTTING ROAD	Green
PROPOSED CONSTRUCTION	Red
COMMON PLOT	Yellow
ROAD WIDENING AREA	Blue
EXISTING (To be retained)	Orange
EXISTING (To be demolished)	White

Buildingwise Floor FAR Details

Floor Name	Building Name A (SHYAMALI HANSDA)		Total	
	Proposed Built Up Area (Sq.mt.)	Proposed FAR Area (Sq.mt.)	Total Proposed Built Up Area (Sq.mt.)	Total FAR Area (Sq.mt.)
Ground Floor	66.60	66.60	66.60	66.60
Terrace Floor	0.00	0.00	0.00	0.00
Total :	66.60	66.60	66.60	66.60

Building USE/SUBUSE Details

Building Name	Building Use	Building SubUse	Building Structure
A (SHYAMALI HANSDA)	Residential	Bungalow/ Dwelling / Non Apartment	Non-Highrise

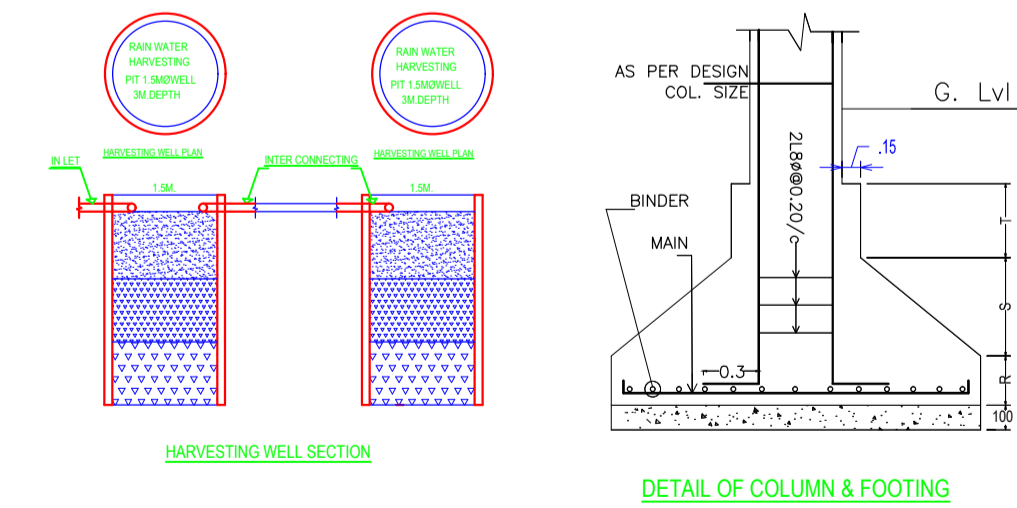

DETAIL OF COLUMN & FOOTING