

Proposal Basic Information

Proposal File No.	CNPC/BP/0005/W05/2019
Owner Name	NOORI BEGUM
Khata No	610
Plot No	1039, 1040
Village Name	Chakulia
Use	Residential
SubUse	Individual Row House

FAR & Tenement Details (Table 4c-1)

Building	No. of Same Bldg	Total Built Up Area (Sq.mt.)	Proposed FAR Area (Sq.mt.) Resi.	Total FAR Area (Sq.mt.)	Total Consumed Additional FAR Area (Sq.mt.)	Tnmt (No.)
A (NOORI BEGUM)	1	22.66	22.66	22.66	22.66	01
Grand Total :	1	22.66	22.66	22.66	22.66	01

AREA STATEMENT CHAKULIA NAGAR PANCHAYAT	VERSION NO. : 1.0.38 VERSION DATE: 29/04/2019
PROJECT DETAIL:	
Region: JHARKHAND URBAN LOCAL BODIES	Plot Use: Residential
District: EAST SINGHBHUM	Plot SubUse: Individual Row House
Authority: CHAKULIA NAGAR PANCHAYAT	PlotNearbyReligiousStructure: NA
Inward No: CNPC/BP/0005/W05/2019	PlotSubPlot No: 1039, 1040
Application Type: General Proposal	North: Survey No. - Md. Jawed
Project Type: Building Permission	South: Survey No. - Md. Jawed
Nature of Development: New	East: Road Width - 3.05
Location of Development Area: Old Area	West: Survey No. - Niz
AREA DETAILS:	
AREA OF PLOT (Minimum)	(A) 58.00
Deduction for NetPlot Area	
Road Widening Area	1.04
Total	1.04
NET AREA OF PLOT(Gross Plot Area - Deduction from Gross Plot area)	(A-Deductions) 56.96
Deduction for Balance Plot Area(from Gross Plot Area)	
Road Widening Area	1.04
Common Plot	7.25
Total	8.29
BALANCE AREA OF PLOT(Net Plot Area - Recreational/Amenity space)	(A-Deductions) 49.71
PLOT AREA FOR COVERAGE(Net Plot Area)	(A-Deductions) 56.96
Plot Area for FAR (Net Plot Area + RoadWidening Area)	(A-Deductions) 56.96
COVERAGE CHECK	
Permissible Coverage area ( 70.00 % )	39.87
Proposed Coverage Area ( 39.78 % )	22.66
Total Prop. Coverage Area ( 39.78 % )	22.66
Balance coverage area ( 30.21 % )	17.21
FAR CHECK	
Perm. FAR Area ( 1.20 )	68.35
Total Perm. FAR area	68.35
Residential FAR	22.66
Proposed FAR Area	22.66
Total Proposed FAR Area	22.66
Consumed FAR (Factor)	0.40
Balance FAR Area	45.69
BUILT UP AREA CHECK	
Total Proposed BuiltUp Area	22.66
ARCHITECT (Regd)	L K SUMAN
ENGINEER (Regd)	
SUPERVISOR (Regd)	
OWNER (Regd)	NOORI BEGUM
DEVELOPMENT AUTHORITY	LOCAL BODY

COLOR INDEX	
PLOT BOUNDARY	Black
ABUTTING ROAD	Green
PROPOSED CONSTRUCTION	Red
COMMON PLOT	Yellow
ROAD WIDENING AREA	Blue
EXISTING (To be retained)	Light Blue
EXISTING (To be demolished)	White

Buildingwise Floor FAR Details				
Floor Name	Building Name A (NOORI BEGUM)		Total	
	Proposed Built Up Area (Sq.mt.)	Proposed FAR Area (Sq.mt.)	Total FAR Area (Sq.mt.)	Total FAR Area (Sq.mt.)
Ground Floor	22.66	22.66	22.66	22.66
Terrace Floor	0.00	0.00	0.00	0.00
Total :	22.66	22.66	22.66	22.66

Building USE/SUBUSE Details			
Building Name	Building Use	Building SubUse	Building Structure
A (NOORI BEGUM)	Residential	Individual Row House	Non-Highrise

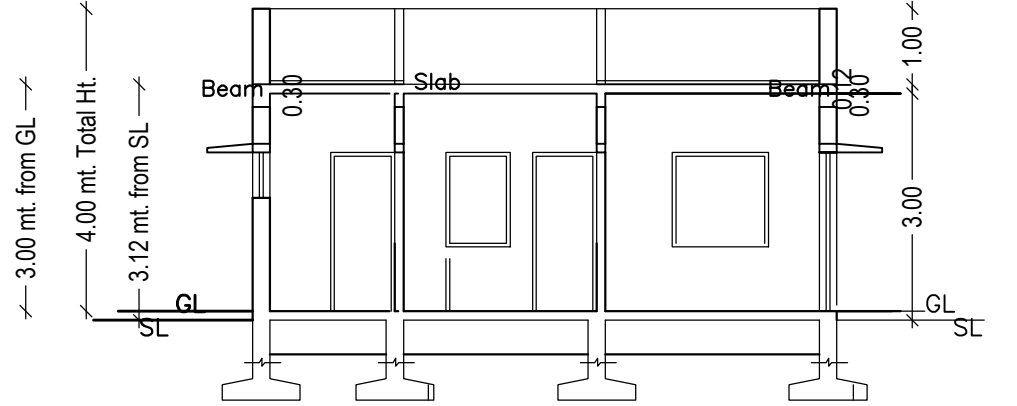
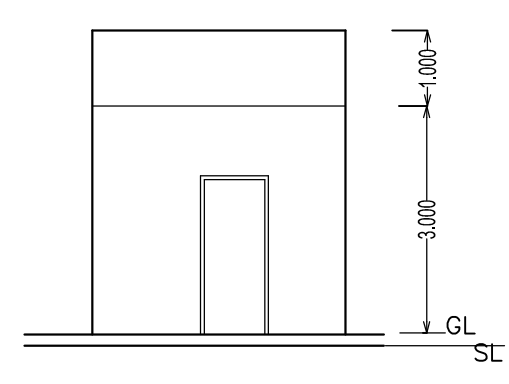
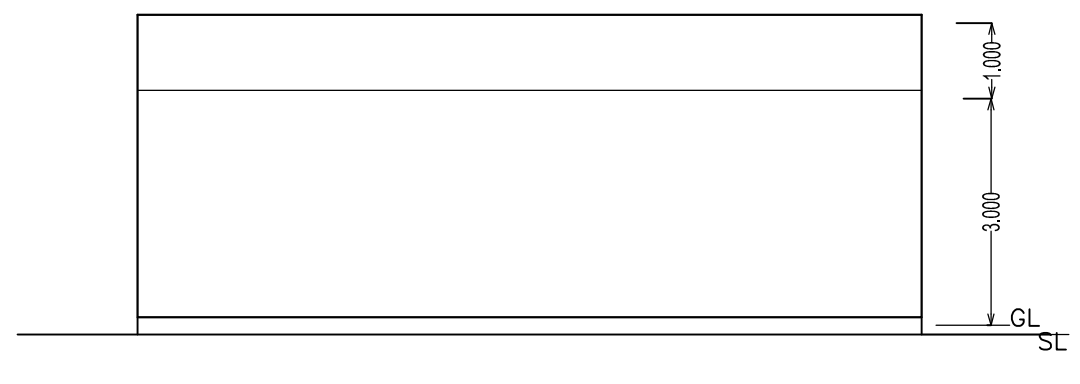
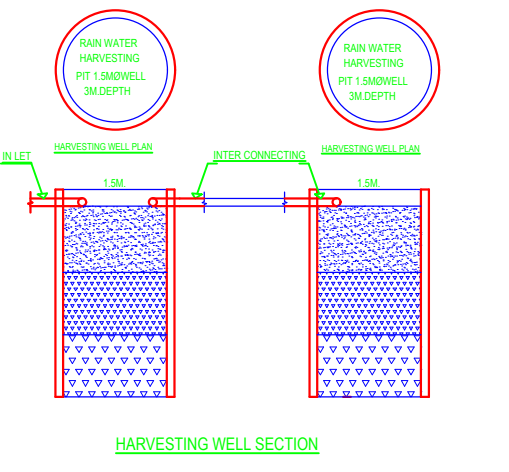
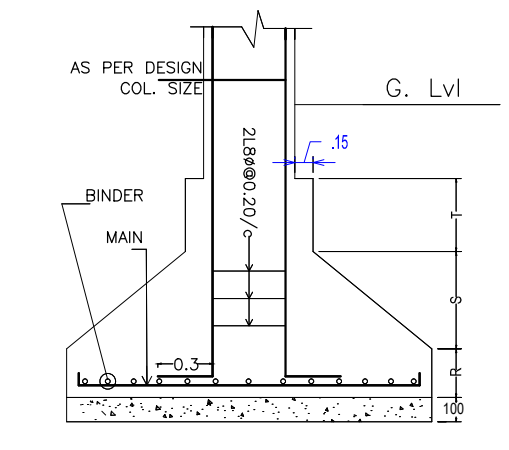
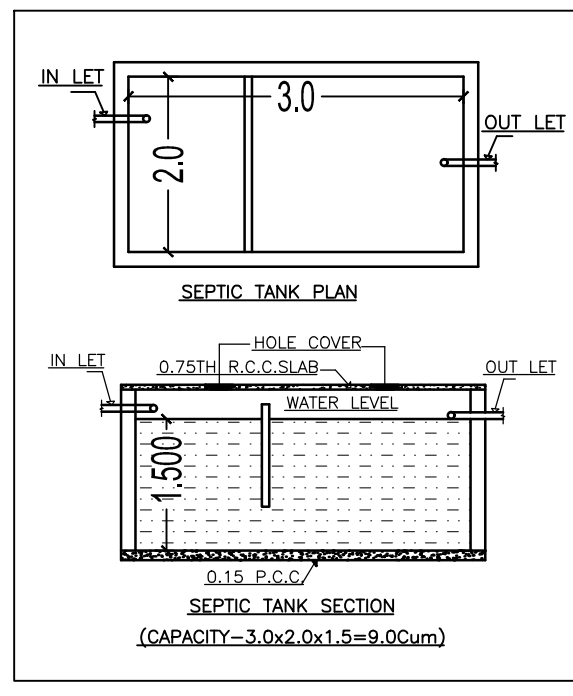
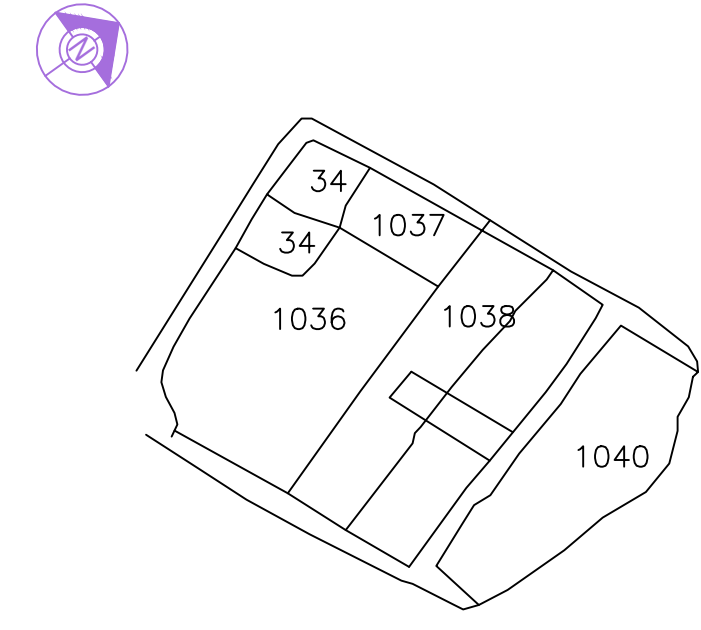
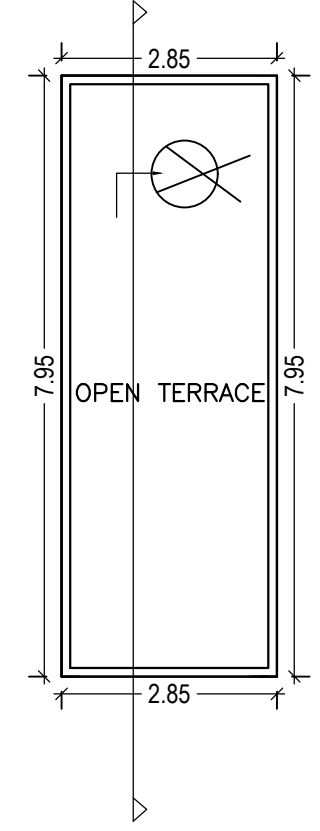
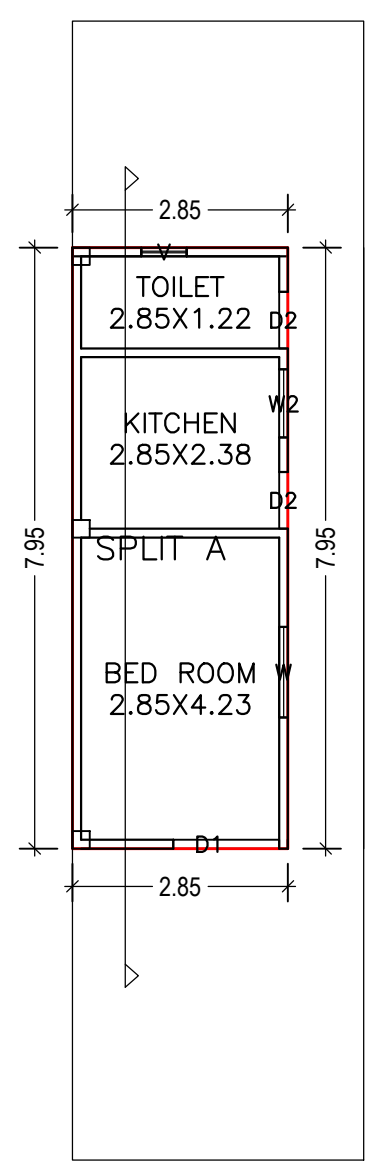
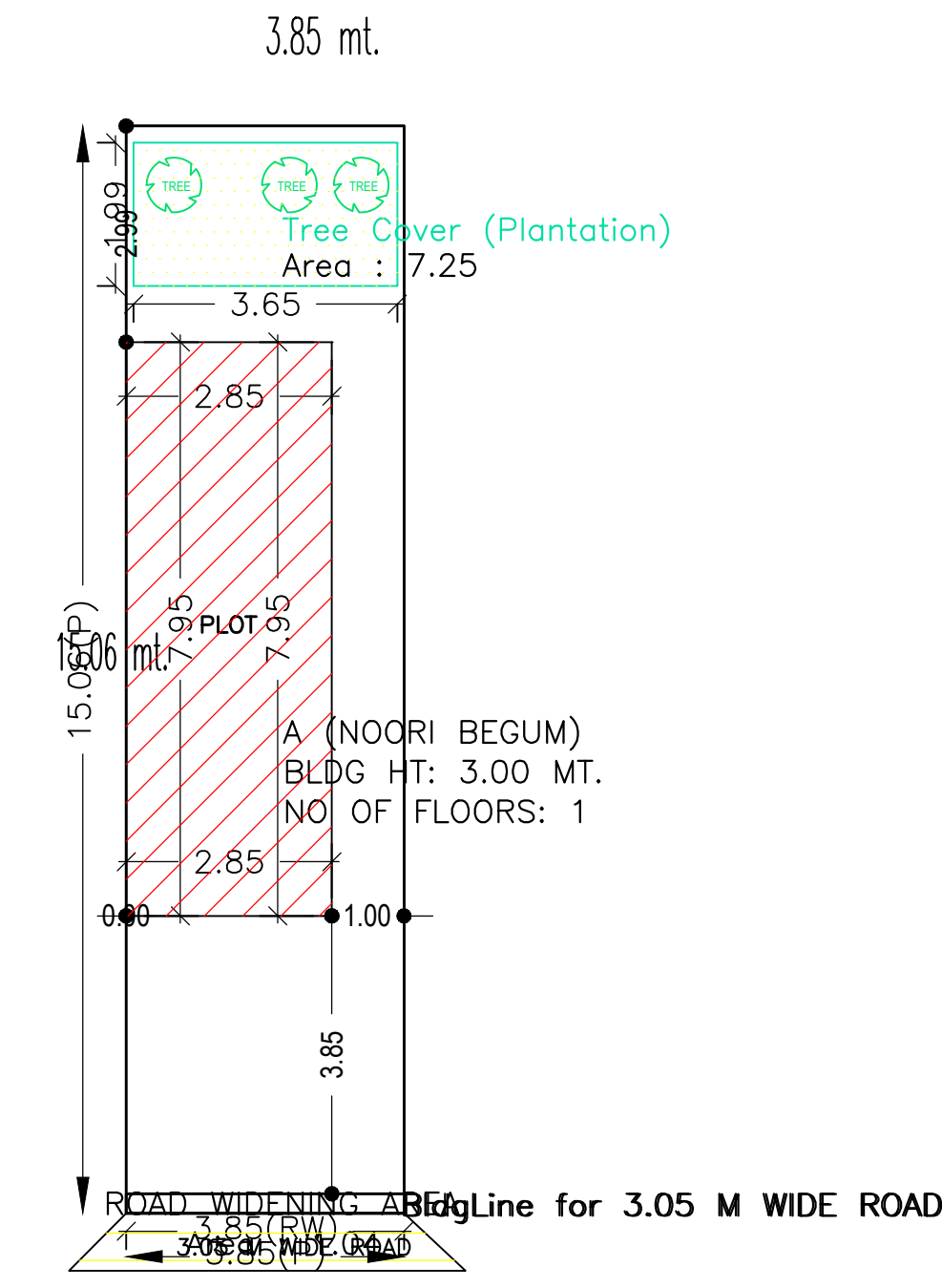

Building :A (NOORI BEGUM)					
Floor Name	Total Built Up Area (Sq.mt.)	Proposed FAR Area (Sq.mt.) Resi.	Total FAR Area (Sq.mt.)	Total Consumed Additional FAR Area (Sq.mt.)	Tnmt (No.)
Ground Floor	22.66	22.66	22.66	22.66	01
Terrace Floor	0.00	0.00	0.00	0.00	00
Total :	22.66	22.66	22.66	22.66	01
Total Number of Same Buildings	1				
Total :	22.66	22.66	22.66	22.66	01

SCHEDULE OF DOOR:				
BUILDING NAME	NAME	LENGTH	HEIGHT	NOS
A (NOORI BEGUM)	D2	0.75	2.10	02
A (NOORI BEGUM)	D1	1.40	2.10	01
SCHEDULE OF WINDOW/VENTILATION:				
BUILDING NAME	NAME	LENGTH	HEIGHT	NOS
A (NOORI BEGUM)	V	0.60	0.60	01
A (NOORI BEGUM)	W2	0.90	1.20	01
A (NOORI BEGUM)	W	1.20	1.20	01

UnitBUA Table for Building :A (NOORI BEGUM)					
GROUND FLOOR PLAN	Name	UnitBUA Type	Carpet Area	No. of Rooms	No. of Tenement
	-	-	22.66	22.40	3
	-	-	22.66	22.40	3

LTP NAME AND SIGNATURE	STRUCTURAL ENG'S NAME AND SIGNATURE	BUILDER NAME AND SIGNATURE	DIGITAL SIGNATURE
L K SUMAN CNPC/ENG/0002/2018			