

- : 5 :-

Saman Mallick
18/6/18

among them, 1/4th share i.e above schedule land has been allotted in the share of the vendor and he is in exclusive peaceful possession of the same and enjoyment of the same without any interruption from anybody, by paying necessary rents to the landlord regularly.

Being in urgent need of money the vendor proposed to sell the above schedule land and the purchaser having offered the highest market price of Rs.9,35,000/- (Rupees nine lakhs thirty five thousand) only, the vendor is hereby selling the above schedule land and executing this sale deed after receipt of full and final consideration money of Rs.9,35,000/- (Rupees nine lakhs thirty five thousand) only, the receipt of which the vendor hereby acknowledged. The vendor has delivered the physical possession of the above schedule land to the purchaser, who will possess and enjoy the same in occupancy raiyati right in all possible ways and will have her name mutated and registered in the office of the landlord and pay rents for the same and obtain rent receipts in her own name.

From today all the right, title, interest and possession of the vendor in the above schedule land will cease to exist and will vest in the purchaser. The above schedule land is free from all encumbrances, lien or charges.

contd...6

सम - चाकुलिया चादरन- I
 गा - घाटीशला - (चाकुलिया)
 प्लान नं० - 328
 तर्फ - पड़िहाटी
 जिला - सिंघभूम, (पूर्वी सिंघभूम)
 पैमाना - 16 = 1 मील, सन - 1960-61 ईस्वी

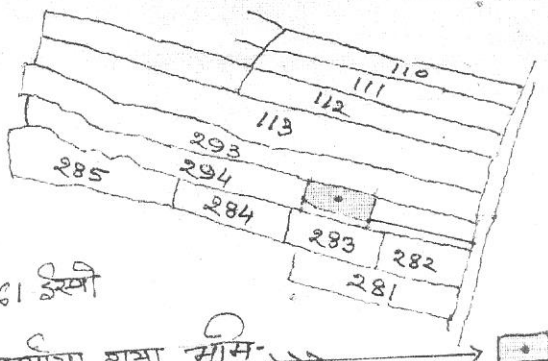

सरजमिन का निशान लाल रंग में दर्शाया गया है।

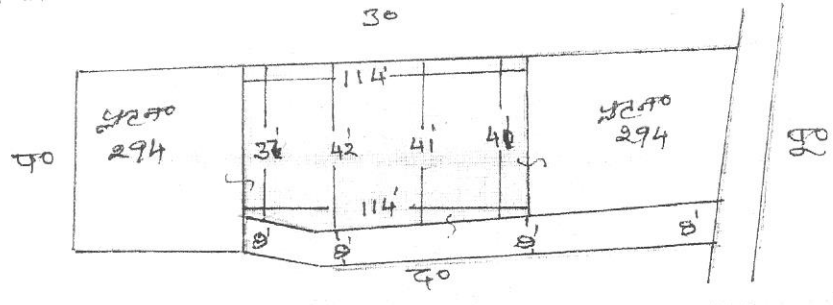

खता नं०	प्लान नं०	विक्रम	रकबा		चौदरी	संख्या
			चौ	दो		
463	294	दोन रुक	-	10.50	30- प्लान नं०-293 40- प्लान नं० 294 का 8' चौड़ाई कमन रास्ता 50- प्लान नं०-294 वाकी जमिन 90- प्लान नं०-294 वाकी जमिन	1. दलिल नं०-5563 दिनांक- 22-07-1977 2. दलिल नं०-8369 दिनांक- 20-12-1978 चाकुलिया अंचल नामाहर म० सं०- 927/79-80

प्रमाणित किया जाता है कि मौजा का मूल नक्शा से इस दस्तावेज नक्शा तैयार किया गया।

Suman Mallick
 18/6/18

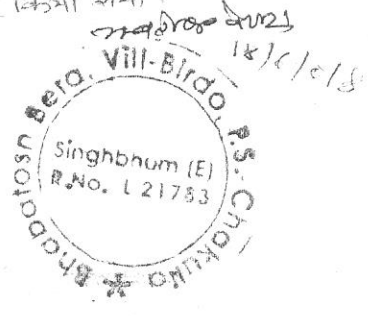

960. 20035000. s. chakuli. 948

②
⑨

Nani Hanakato

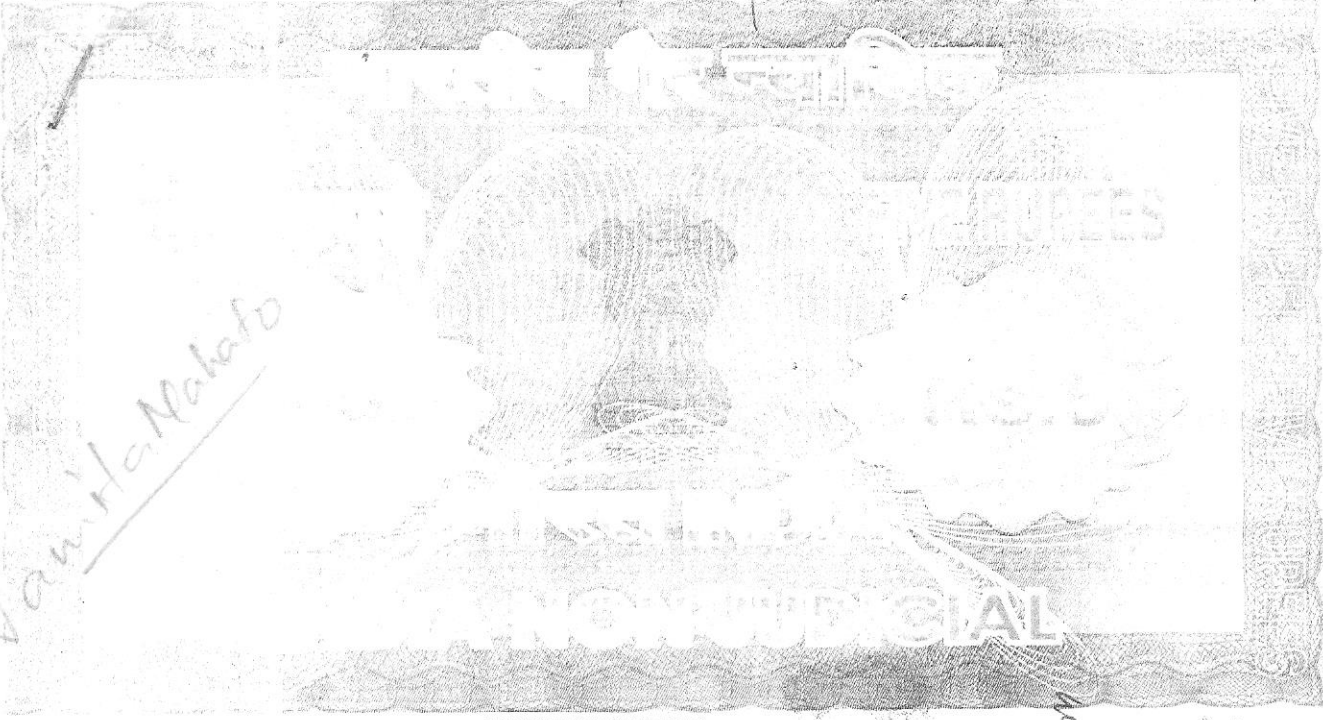

गणराज्य की कानून
केन्द्र का कार्यालय
नया दिल्ली

18/6/18

23

18/6/18

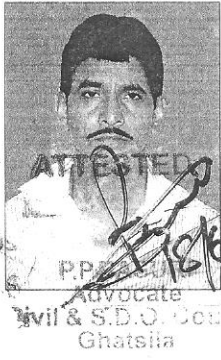

Jomon Mahalik
18/6/18

03:30 AM
18/6/18
11:30 AM

~~18/6/18~~

Place Ghatsila
Certify that the
secure prints
been obtained

18/6/18
Fee charge

AG 00.00
Seal 2.50
P. 0.94

463
224
18/6/18

गणराज्य
18/6/18

18/6/18

SALE DEED

contd....2

- : 6 : -

Soman Mallik
18/6/18

The vendor has not charged or transferred the above schedule land with anybody else previously and for any defect of title or possession of the vendor, if the purchaser suffers any loss, then the vendor will be liable to compensate the same.

The terms vendor and purchaser used in this deed will mean and include their heirs, successors etc. unless the same is repugnant to the context.

In witness whereof the vendor doth hereunto sets and subscribes his hand on it on this the 18th day of June, 2018 at Ghatasila.

Readover and explained the contents of this deed of sale to the vendor, who admitted the same to be true and correct.

P. P. Basu, Ghatasila.
Adv. 18/6/18

WITNESSES:

1. Bishwa Pal Mallik s/o Late Bijay Kumar Mallik of vil. Sugnibosa, Chakulia P.S. Chakulia, Dist. East Singhbhum. 18/6/18
2. Ganesh Mahato s/o Dina Bandu Mahato At. P. Simli Chakulia 18/6/18

Typed by:
S. Garai, Ghatasila.
18.6.18.

9931687452

Drafted by:

[Signature]
Advocate.
18/6/18

Samar Mallick
18/6/18

- : 2 :-

VENDOR: Samar Mallick, son of late Ratan Kumar Mallick,
by faith Hindu, by caste Gandha Banik, by
occupation Business, resident of village
208 Sugnibasa, Near Rly Station, Chakulia, P.O.
& P.S. Chakulia, Dist. East Singhbhum, Jharkhand.
(NON ST, SC & BC).
PAN NO. BHVPM1248M.

PURCHASER: Namita Mahato W/O Krishna Pada Mahato, by
faith Hindu, by caste Kurmi, by occupation
house hold affairs, by nationality Indian,
resident of village Kantaboni, P.O. Kendadangri,
P.S. Chakulia, Dist. East Singhbhum, Jharkhand.
PAN NO. DECPM2928L.

NATURE OF DEED: SALE DEED.

CONSIDERATION MONEY: Rs. 9,35,000/- (Rupees nine lakhs
thirty five thousand) only.

SCHEDULE (DESCRIPTION OF THE PROPERTY HEREBY SOLD):

In the district of East Singhbhum, pargana Dhalbhum,
District Sub Registry Office at Jamshedpur, sub Registry
Office at Chatsila, in mouza Chakulia, survey thana
no. 328, Halka no. IV, P.S. & Anchal Chakulia, recorded

contd...3

- : 3 :-

Soman-Mallik
18/6/18

under:

<u>Khata no.</u>	<u>plot no.</u>	<u>Area</u>	<u>Boundary</u>
463	294 D-I	10.50 decimals	N: plot no.293, S: plot no. 294, 8' wide common Rasta. E & W: Rest portion of plot no. 294.

(ten point five zero decimals) of
raiyaati land.

Annual rent: Rs.5/- payable to the Landlord, the
state of Jharkhand, through the C.O. at Chakulia.

The location of the land shown in the sketch map
in red colour annexed herewith, which will be treated
as form part of this sale deed.

PURPOSE: For Homestead Purpose.

KNOW ALL MEN BY THESE PRESENTS that the vendor is
the absolute owner of the raiyaati land morefully described
in the schedule above, which previously belonged to and
recorded in 1964 survey settlement operation in the name
of Haripada Das, by caste Baisnab, (Non ST, S_c & BC).

contd....4

- : 7 :-

Soman Mallick
18/6/18



Namita Maheto
Ghatia



Namita Maheto
18.6.18

Certified that the finger prints of the left hand of
the claimant, whose photograph is affixed in the
document have been obtained by me or before me.

Advocate
[Signature]
18/6/18

Samar Mallick
18/6/18

That the above schedule land alongwith other lands total measuring 42 decimals in plot no. 294, khata no. 463 has been purchased by the deceased father of the vendor namely Ratan Kumar Mallick S/O late Rosta Bihari Mallick vide two respective sale deeds from it's previous rightful owner namely smt. Mirmala Bala Das W/O Sri Haripada Das by caste Baishnab (Non ST, SC & BC), vide Regd. sale deed no. 5563 dated 22.7. 1977 and vide regd. sale deed no. 8869 dated 20.12. 1978, both deeds registered at Sub Registry Office, Jamshedpur and thereafter which has been mutated in his name vide mutation case no. 927 /79-80 through the C.O. Chakulia and also which has been entered in the Register-II of the Anchal Office in his name in volume no. 2, page no. 555 and till his life time he was in peaceful possession of the same by paying necessary rents to the landlord regularly.

Samar Mallick
18/6/18

That, aforesaid Ratan Kumar Mallick died leaving his four sons including the vendor i.e. 1. Hara Gopal Mallick, 2. Hari Sadhan Mallick, 3. Samar Mallick, (Vendor) 4. Ashim Mallick as his only legal heirs and successors. After his death, the vendor and his other brothers have inherited the same and after amicable partition made

contd.,.5

no 2
2.6.18



AFFIDAVIT

I, NAMITA MAHATO w/o KRISHNA PADA MAHATO by faith
HINDU by Nationality Indian, resident of
KANTABONI P.S. CHAKULIA Dist. EAST
SINGBHUM, Jharkhand, do hereby
solemnly affirm and declared as follows:

1. That I am the Purchaser/s of the property i.e. land/house/flat, situated at Mouza CHAKULIA Thana.No.: 328 Halka IV, Khata no.: 463 Plot no.: 294 Area: 10.50 DECIMALS
2. The previously I have not taken any benefits regarding registration of sale deed by the notification of state of Jharkhand, vide its notification Ref. No.: 499 for stamp duty and vide its no. 500 for registration fees, both dated 19.06.2017.
3. That I intend to get the sale deed registered my name in the registering authority at Jámshedpur in first time in respect of the aforesaid property as per notification of the State of Govt. Jharkhand.
4. That I swear this affidavit to declare the above facts and to produce the same before the Registration office.

VIRIFICATION

Identified by

Shri P. P. BASURI
Advocate,
Ghatsila court.

The Statement made above are true to the best of my knowledge, belief and information and I sign on this 12.6.18 onat Ghatsila Court.

Namita Mahato

DEPONENT

Identified by me:

[Signature]
Advocate. 12/6/18

[Signature] 12.6.18
Notary Public
Prasenjit Mishra
Ghatsila
Notary
Shri. Sri. Singhania
30/06/2018