

Project Title - MANAS SOREN

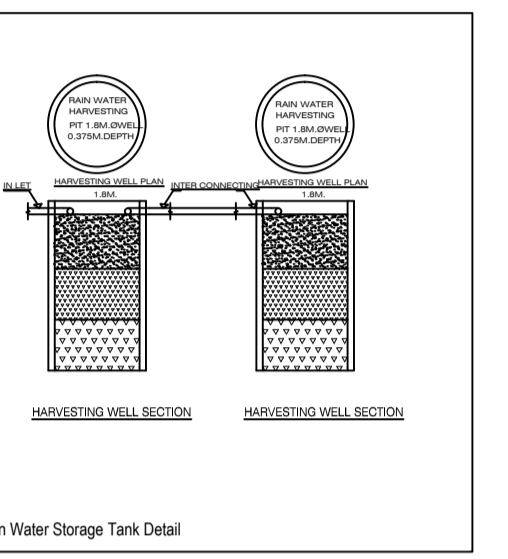
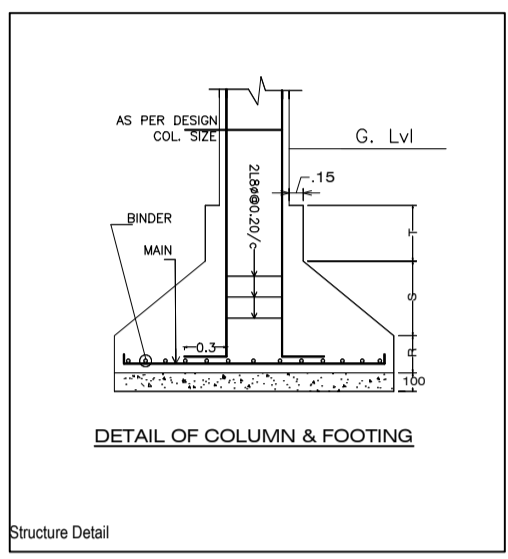
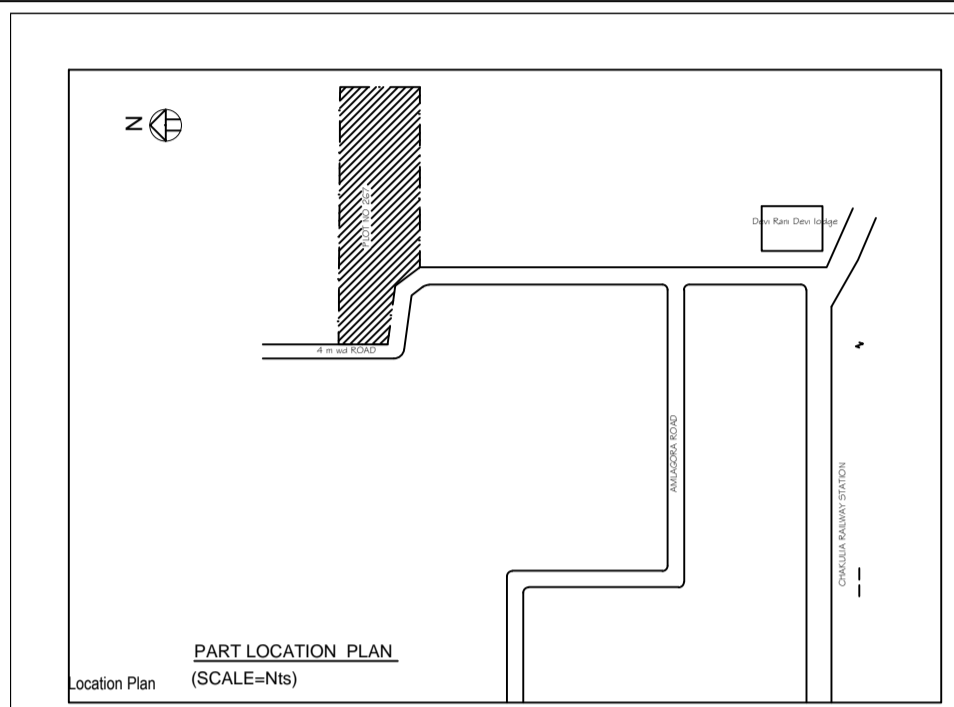
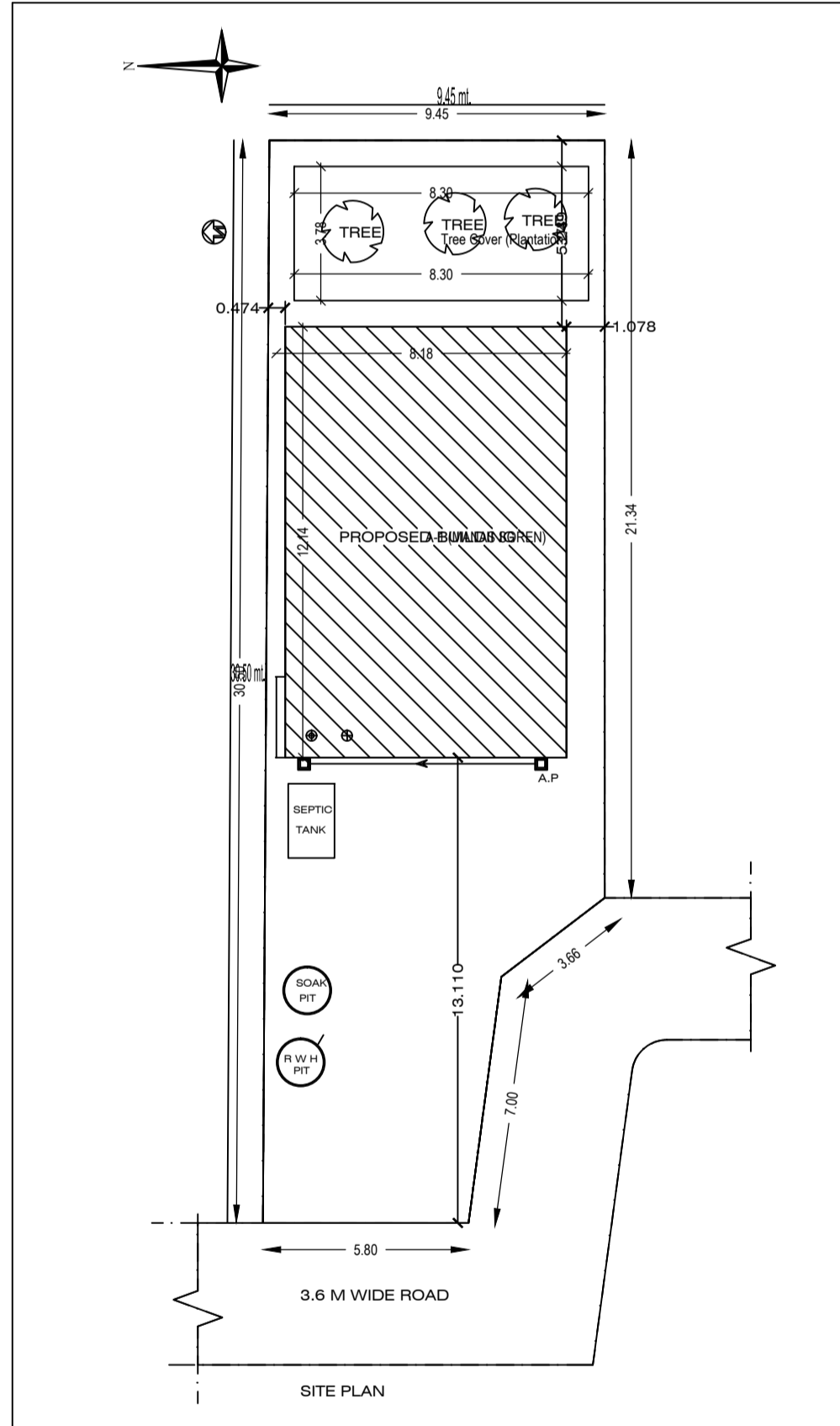

DOOR WINDOW AND VENTILATION DETAIL

| Sl. No. | TYPE | LENGTH | HEIGHT | NO. | DESCRIPTION |
|---------|------|--------|--------|-----|---------------------|
| 1 | DO | 1.20m | 2.10m | 2 | FULLY GLAZED DOOR |
| 2 | DO | 1.20m | 2.10m | 2 | FULLY GLAZED DOOR |
| 3 | DO | 0.75m | 0.30m | 2 | FULLY GLAZED DOOR |
| 4 | WT | 1.20m | 1.20m | 2 | FULLY GLAZED WINDOW |
| 5 | WT | 1.20m | 1.20m | 2 | FULLY GLAZED WINDOW |
| 6 | WT | 1.20m | 1.20m | 2 | FULLY GLAZED WINDOW |

NOTE:
 1. FOUNDATION & R.C.C. AS PER STRUCTURAL ENGG. SPECIFICATION
 2. ALL DIMENSIONS IN METRE
 3. EXISTING STRUCTURE TO DIMOLISHED
 4. DRAWING NOT TO BE SCALED

OFFICE USE

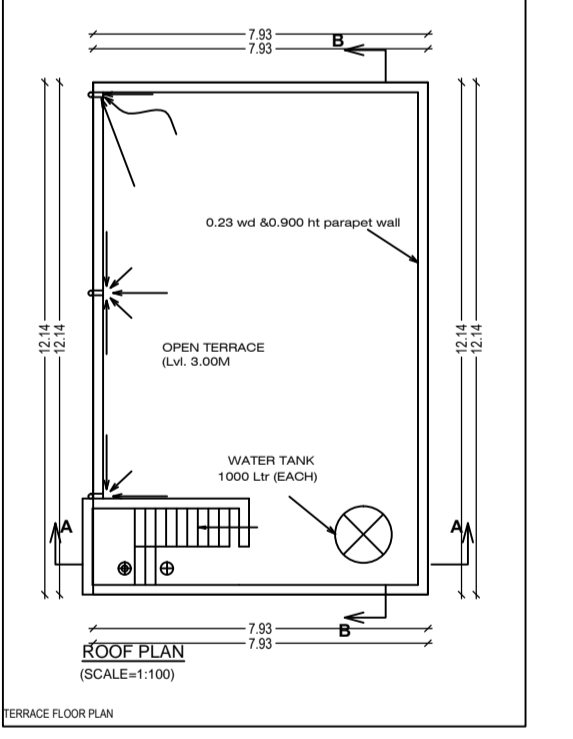
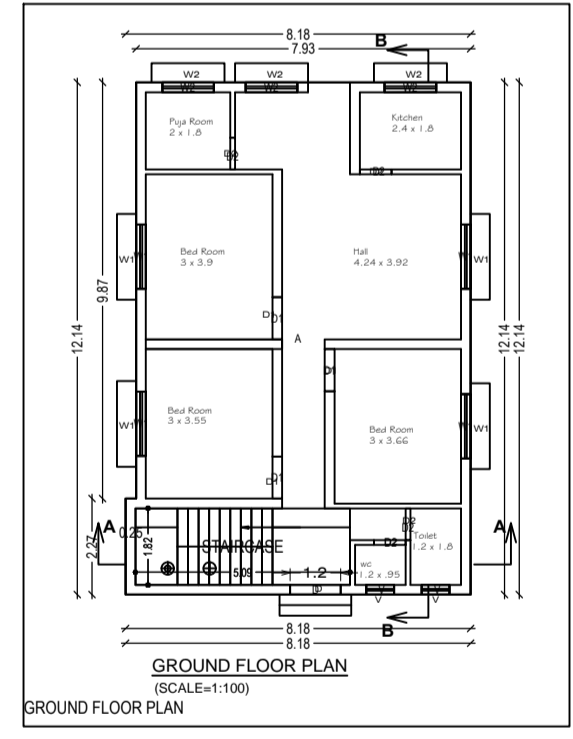
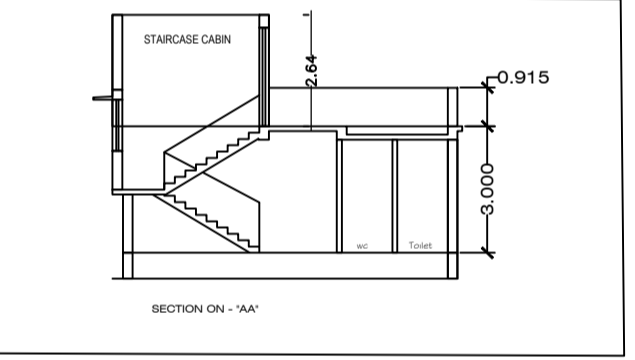
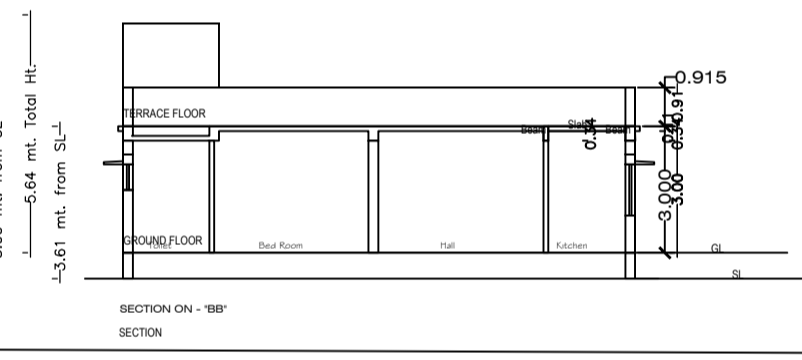
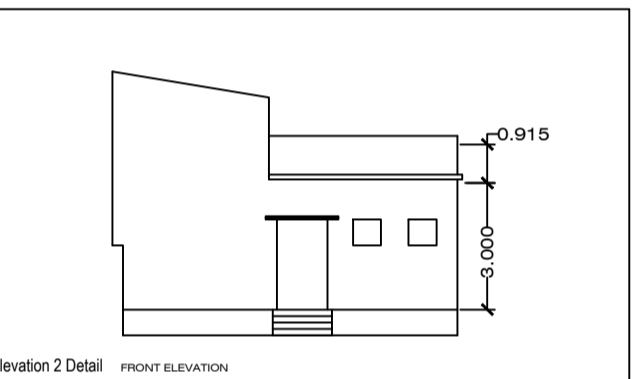
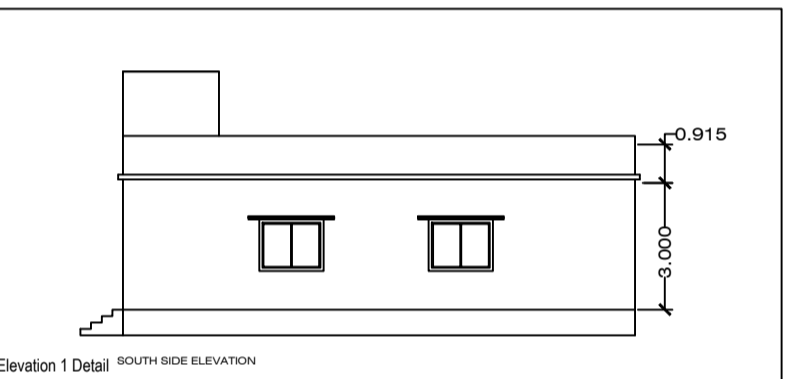

PROJECT DATA

| | |
|---------------|---------------------|
| Project No. | 12/25 |
| Project Name | MANAS SOREN |
| Client Name | Mr/Mrs. MANAS SOREN |
| Location | CHAKULIA |
| Plot Area | 36.84 Sq.Mt. |
| Building Area | 36.84 Sq.Mt. |
| Construction | REINFORCED CONCRETE |
| Foundation | RAFT |
| Roof | ROOF TOP |
| Structure | RESIDENTIAL |
| Use | RESIDENTIAL |
| Scale | 1:100 |
| Date | 12/25 |
| Drawn By | CHAKULIA |
| Checked By | CHAKULIA |
| Approved By | CHAKULIA |

AREA DETAILS

| Sl. No. | DESCRIPTION | AREA (Sq.Mt.) |
|---------|--|---------------|
| 1 | NET FLOOR COVERED AREA | 36.84 |
| 2 | NET FLOOR COVERED AREA (Including Terrace) | 36.84 |
| 3 | NET FLOOR COVERED AREA (Including Terrace & Staircase) | 36.84 |
| 4 | NET FLOOR COVERED AREA (Including Terrace, Staircase & Lift) | 36.84 |
| 5 | NET FLOOR COVERED AREA (Including Terrace, Staircase, Lift & Common Area) | 36.84 |
| 6 | NET FLOOR COVERED AREA (Including Terrace, Staircase, Lift, Common Area & Parking) | 36.84 |
| 7 | NET FLOOR COVERED AREA (Including Terrace, Staircase, Lift, Common Area, Parking & Road) | 36.84 |
| 8 | NET FLOOR COVERED AREA (Including Terrace, Staircase, Lift, Common Area, Parking, Road & Boundary) | 36.84 |
| 9 | NET FLOOR COVERED AREA (Including Terrace, Staircase, Lift, Common Area, Parking, Road, Boundary & Green Area) | 36.84 |
| 10 | NET FLOOR COVERED AREA (Including Terrace, Staircase, Lift, Common Area, Parking, Road, Boundary, Green Area & Water Body) | 36.84 |

COLOR INDEX

| | |
|--------|--------|
| Color | Symbol |
| Red | ▬ |
| Blue | ▬ |
| Green | ▬ |
| Yellow | ▬ |
| Black | ▬ |

MARGIN DETAIL

| Sl. No. | ROAD NAME | FRONT MARGIN | REAR MARGIN | SIDE MARGIN | SETBACK MARGIN |
|---------|-----------------|--------------|-------------|-------------|----------------|
| 1 | 3.6 M WIDE ROAD | 4.10 | 5.25 | 2.28 | 1.08 |

FAR & Tenement Details (Table 4c-1)

| Building | No. of Same Use | Total Built Up Area (Sq.Mt.) | Proposed FAR Area (Sq.Mt.) | Total FAR Area (Sq.Mt.) | Use (No.) |
|--------------|-----------------|------------------------------|----------------------------|-------------------------|-----------|
| 1 | 1 | 36.84 | 36.84 | 36.84 | 01 |
| Total | 1 | 36.84 | 36.84 | 36.84 | 01 |

APPROVED:-

EX. OFFICER, Chakulia
OWNER / POAH

Signature of Applicant:-

GENERAL SPECIFICATION :-
 FOUNDATION: PLAN: CEMENT CONCRETE AS PER DESIGN. R.C.C. COLUMN FOOTING & COLUMN AS PER STRUCTURAL DESIGN.
 SUPER STRUCTURE: R.C.C. COLUMN & BEAM AS PER STR. DESIGN. 0.25M THK. EXT. WALL & 0.15M THK. PARTITION WALL IN CEMENT MORTAR.
 FLOOR: ROOF SLAB AS PER STRUCTURAL DESIGN. FLOOR: MOSAIC GAST IN BRU CERAMIC TILES GADDI IN TOILET.
 INTERNAL FINISH: CEMENT PLASTER WITH P.O.P & O.B.D.
 SANITARY: WHITE CERAMIC GLAZ SANITARY WARE. G.I. PIPE WATER SUPPLY.
 P.V.C PIPE FOR SEWAGE DISPOSAL.
 DOORS & WINDOW AS PER SCHEDULE.
 ELECTRICAL COPPER WIRE WITH P.V.C. CONDUIT.

PROPOSED RESIDENTIAL BUILDING PLAN
 Mr/Mrs. - MANAS SOREN
 S/O - Late Gobind Soren
 H.NO. - 008000403000A1
 Mouza- Kankrishole
 DISTRICT - EAST SINGHBHUM, JHARKHAND
 TOWN - CHAKULIA.

Building A (MANAS SOREN)

| Floor Name | Total Built Up Area (Sq.Mt.) | Proposed FAR Area (Sq.Mt.) | Total FAR Area (Sq.Mt.) | Use (No.) |
|---------------|------------------------------|----------------------------|-------------------------|-----------|
| Ground Floor | 36.84 | 36.84 | 36.84 | 01 |
| Terrace Floor | 0.00 | 0.00 | 0.00 | 00 |
| Total | 36.84 | 36.84 | 36.84 | 01 |

SCHEDULE OF JOINERY:

| Building Name | Name | Length | Height | No. of |
|---------------|------|--------|--------|-----------|
| MANAS SOREN | DO | 0.75 | 2.10 | 04 |
| MANAS SOREN | WT | 1.20 | 1.20 | 03 |
| MANAS SOREN | WT | 1.20 | 2.10 | 01 |
| Total | | | | 08 |

SCHEDULE OF JOINERY:

| Building Name | Name | Length | Height | No. of |
|---------------|------|--------|--------|-----------|
| MANAS SOREN | DO | 0.86 | 1.80 | 02 |
| MANAS SOREN | WT | 1.20 | 1.20 | 03 |
| MANAS SOREN | WT | 1.20 | 1.20 | 04 |
| Total | | | | 09 |

UHBIA Table for Building A (MANAS SOREN)

| FLOOR | Name | USE/TYPE | UHBIA Area | Covered Area | No. of Rooms | No. of Tenement |
|--------------|------|----------|--------------|--------------|--------------|-----------------|
| GROUND FLOOR | A | FLAT | 36.84 | 36.10 | 10 | 1 |
| Total | | | 36.84 | 36.10 | 10 | 1 |