

Proposal Basic Information	
Proposal File No.	CNPC/BP/0002/W06/2021
Owner Name	DOLLI MAHATO
Khata No	816
Plot No	2188
Village Name	Chakulia
Use	Residential
SubUse	Bungalow/ Dwelling / Non Apartment

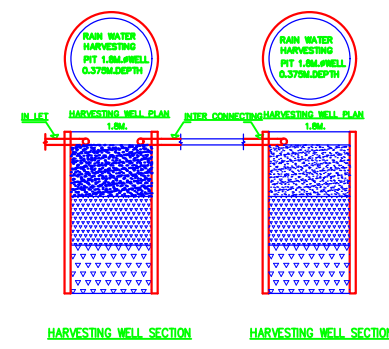
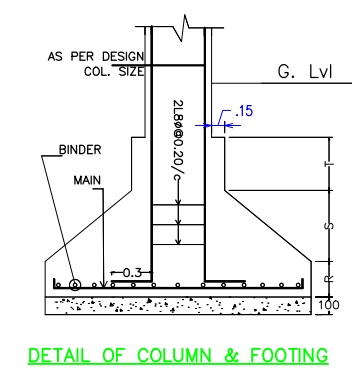
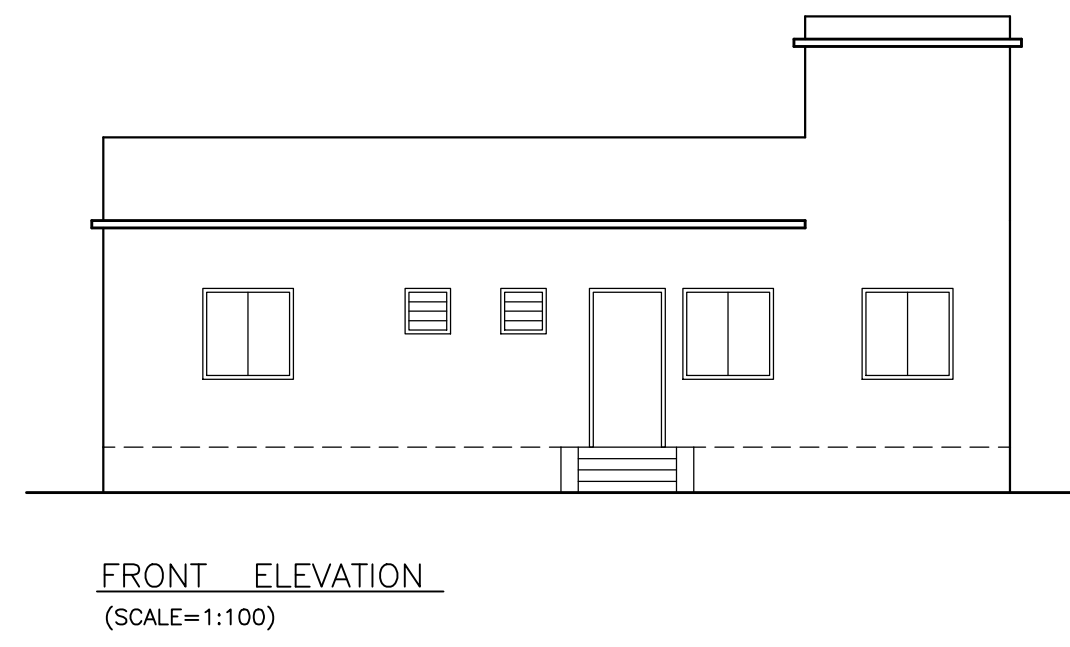
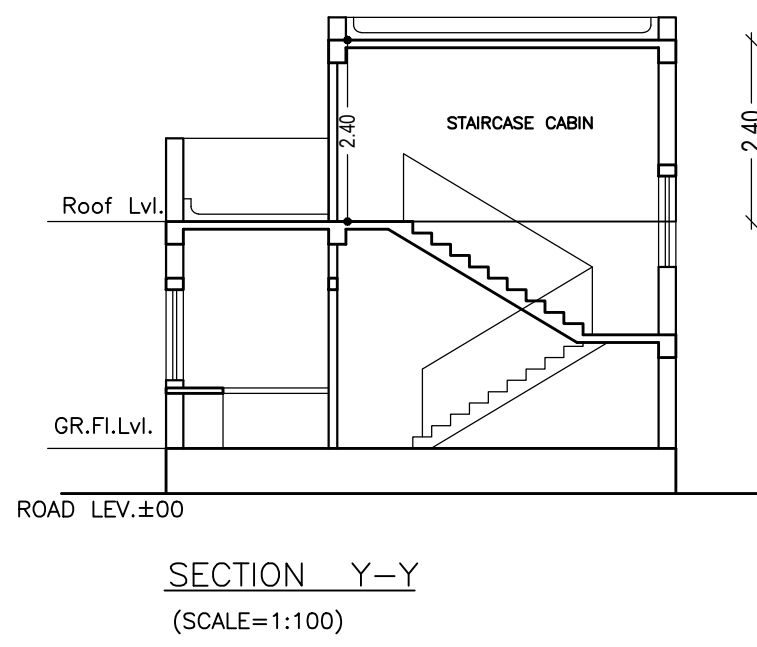
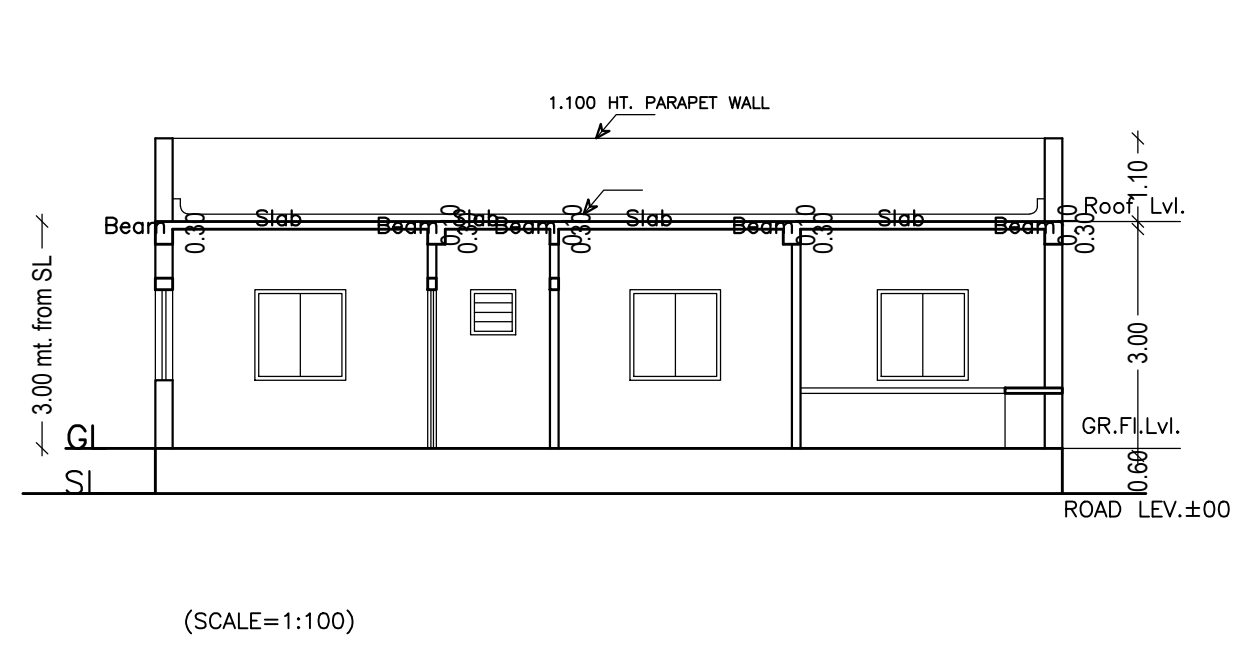
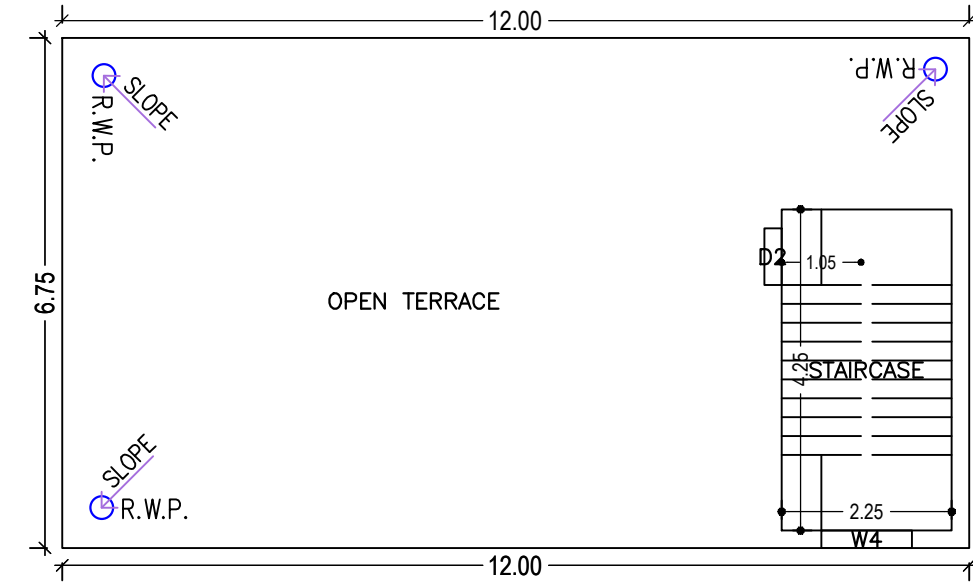
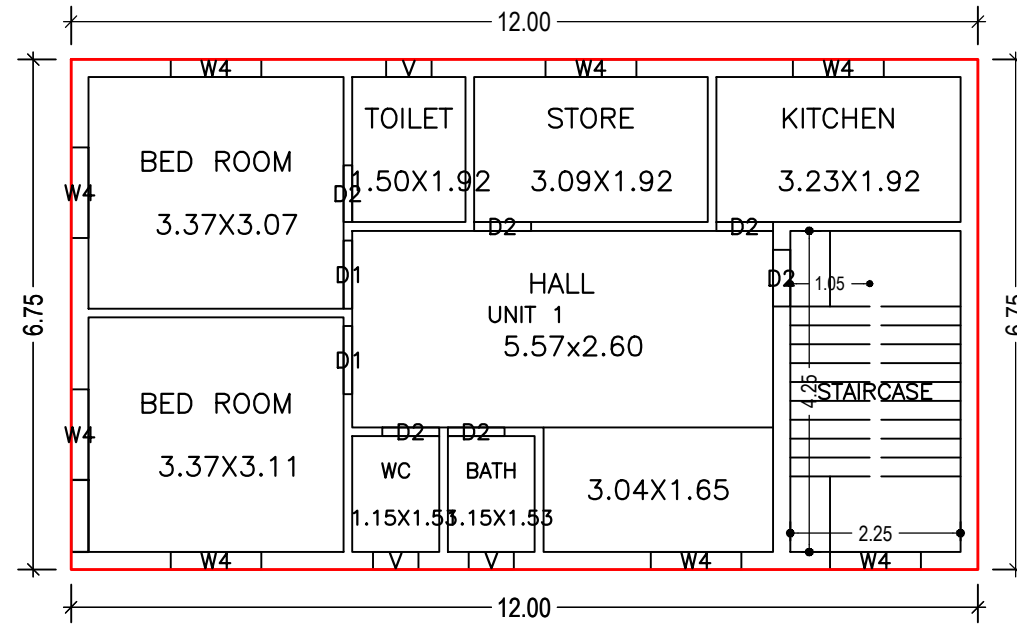
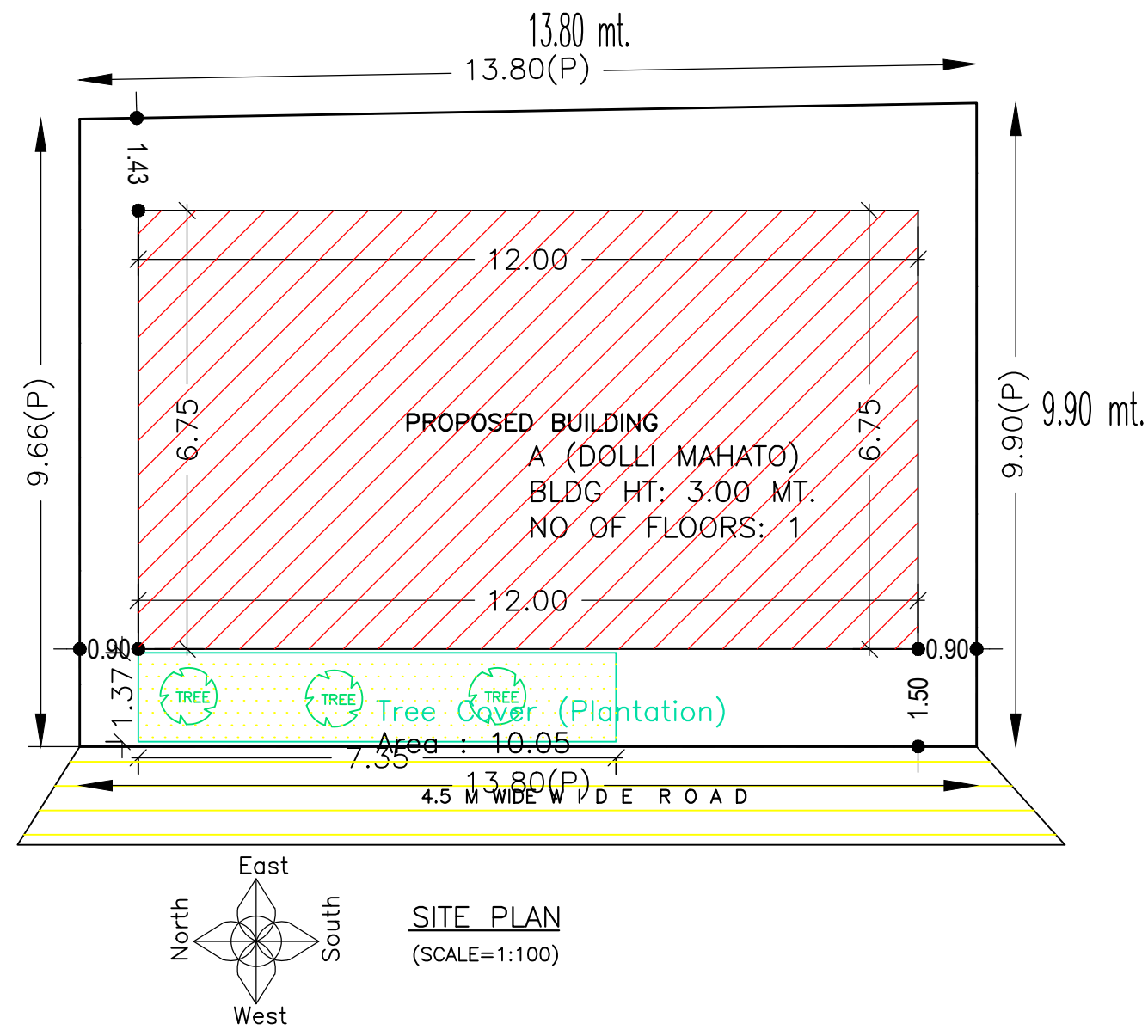

COLOR INDEX	
PLOT BOUNDARY	Black
ABUTTING ROAD	Green
PROPOSED CONSTRUCTION	Red
COMMON PLOT	Yellow
ROAD WIDENING AREA	Blue
EXISTING (To be retained)	Light Blue
EXISTING (To be demolished)	Light Yellow

AREA STATEMENT CHAKULIA NAGAR PANCHAYAT	VERSION NO.: 1.0.53 VERSION DATE: 16/10/2020
PROJECT DETAIL: Region: JHARKHAND URBAN LOCAL BODIES	Plot Use: Residential
District: EAST SINGHBHUM	Plot SubUse: Bungalow/ Dwelling / Non Apartment
Authority: CHAKULIA NAGAR PANCHAYAT	PlotNearbyReligiousStructure: NA
Inward No CNPC/BP/0002/W06/2021	Plot/SubPlot No: 2188
Application Type: General Proposal	North: Survey No. - other plot
Project Type: Building Permission	South: Survey No. - Alley
Nature of Development: New	East: Survey No. - other plot
Location of Development Area: Old Area	West: Road Width - 4.5
AREA DETAILS:	SQ.MT.
AREA OF PLOT (Minimum)	(A) 134.89
NET AREA OF PLOT(Gross Plot Area - Deduction from Gross Plot area)	(A-Deductions) 134.89
Deduction for Balance Plot Area(from Gross Plot Area)	
Common Plot	10.05
Total	10.05
BALANCE AREA OF PLOT(Net Plot Area - Recreational/Amenity space)	(A-Deductions) 124.84
PLOT AREA FOR COVERAGE(Net Plot Area)	(A-Deductions) 134.89
Plot Area for FAR (Net Plot Area + RoadWidening Area)	(A-Deductions) 134.89
COVERAGE CHECK	
Permissible Coverage area (70.00 %)	94.42
Proposed Coverage Area (59.99 %)	80.92
Total Prop. Coverage Area (59.99 %)	80.92
Balance coverage area (10.01 %)	13.50
FAR CHECK	
Perm. FAR Area (1.50)	202.33
Total Perm. FAR area	202.33
Residential FAR	80.92
Proposed FAR Area	80.92
Total Proposed FAR Area	80.92
Consumed FAR (Factor)	0.60
Balance FAR Area	121.41
BUILT UP AREA CHECK	
Total Proposed BuiltUp Area	80.92
ARCHITECT (Regd)	L K SUMAN
ENGINEER (Regd)	
SUPERVISOR (Regd)	
OWNER (Regd)	DOLLI MAHATO
DEVELOPMENT AUTHORITY	LOCAL BODY

Building :A (DOLLI MAHATO)

Floor Name	Total Built Up Area (Sq.mt.)	Proposed FAR Area (Sq.mt.) Resi.	Total FAR Area (Sq.mt.)	Total Consumed Additional FAR Area (Sq.mt.)	Tnmt (No.)
Ground Floor	80.92	80.92	80.92	80.92	01
Terrace Floor	0.00	0.00	0.00	0.00	00
Total	80.92	80.92	80.92	80.92	01
Total Number of Same Buildings	1				
Total	80.92	80.92	80.92	80.92	01

SCHEDULE OF DOOR:

BUILDING NAME	NAME	LENGTH	HEIGHT	NOS
A (DOLLI MAHATO)	D2	0.75	2.10	06
A (DOLLI MAHATO)	D1	0.90	2.10	02

SCHEDULE OF WINDOW/VENTILATION:

BUILDING NAME	NAME	LENGTH	HEIGHT	NOS
A (DOLLI MAHATO)	V	0.60	0.60	03
A (DOLLI MAHATO)	W4	1.20	1.20	09

UnitBUA Table for Building :A (DOLLI MAHATO)

FLOOR	Name	UnitBUA Type	UnitBUA Area	Carpet Area	No. of Rooms	No. of Tenement
GROUND FLOOR PLAN	UNIT 1	FLAT	80.92	80.70	8	1
Total:	-	-	80.92	80.70	8	1

FAR & Tenement Details (Table 4c-1)

Building	No. of Same Bldg	Total Built Up Area (Sq.mt.)	Proposed FAR Area (Sq.mt.) Resi.	Total FAR Area (Sq.mt.)	Total Consumed Additional FAR Area (Sq.mt.)	Tnmt (No.)
A (DOLLI MAHATO)	1	80.92	80.92	80.92	80.92	01
Grand Total:	1	80.92	80.92	80.92	80.92	01

Building USE/SUBUSE Details

Building Name	Building Use	Building SubUse	Building Structure
A (DOLLI MAHATO)	Residential	Bungalow/ Dwelling / Non Apartment	Non-Highrise

Buildingwise Floor FAR Details

Floor Name	Building Name A (DOLLI MAHATO)		Total	
	Proposed Built Up Area (Sq.mt.)	Proposed FAR Area (Sq.mt.)	Total Proposed Built Up Area (Sq.mt.)	Total FAR Area (Sq.mt.)
Ground Floor	80.92	80.92	80.92	80.92
Terrace Floor	0.00	0.00	0.00	0.00
Total :	80.92	80.92	80.92	80.92

LTP NAME AND SIGNATURE	STRUCTURAL ENG'S NAME AND SIGNATURE	BUILDER NAME AND SIGNATURE	DIGITAL SIGNATURE
L K SUMAN CNPC/ENG/0002/2018			