

Proposal Basic Information

Proposal File No.	CNPC/BP/0014/W/10/2023
Owner Name	SUCHETA SAHOO
Khata No	39
Plot No	284
Village Name	Chakulia
Use	Residential
SubUse	Bungalow/ Dwelling / Non Apartment

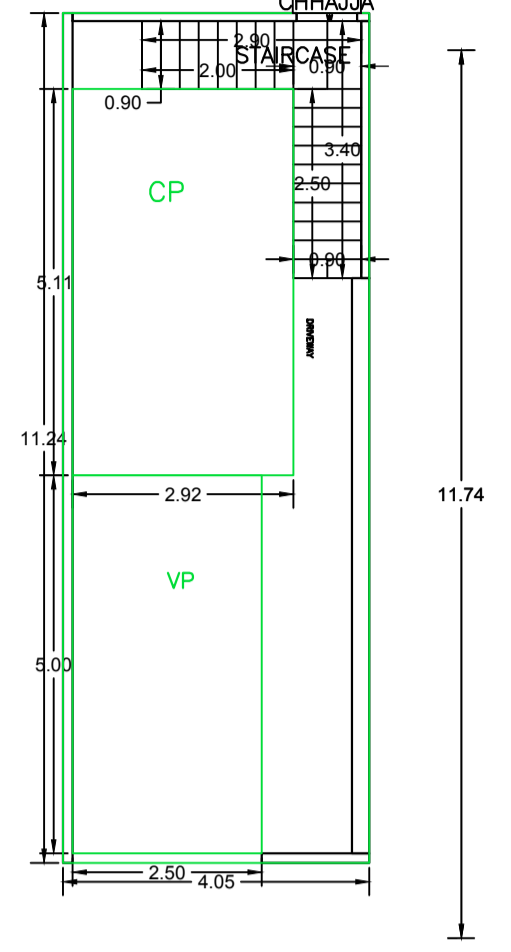

GROUND FLOOR PLAN (SCALE 1:100)

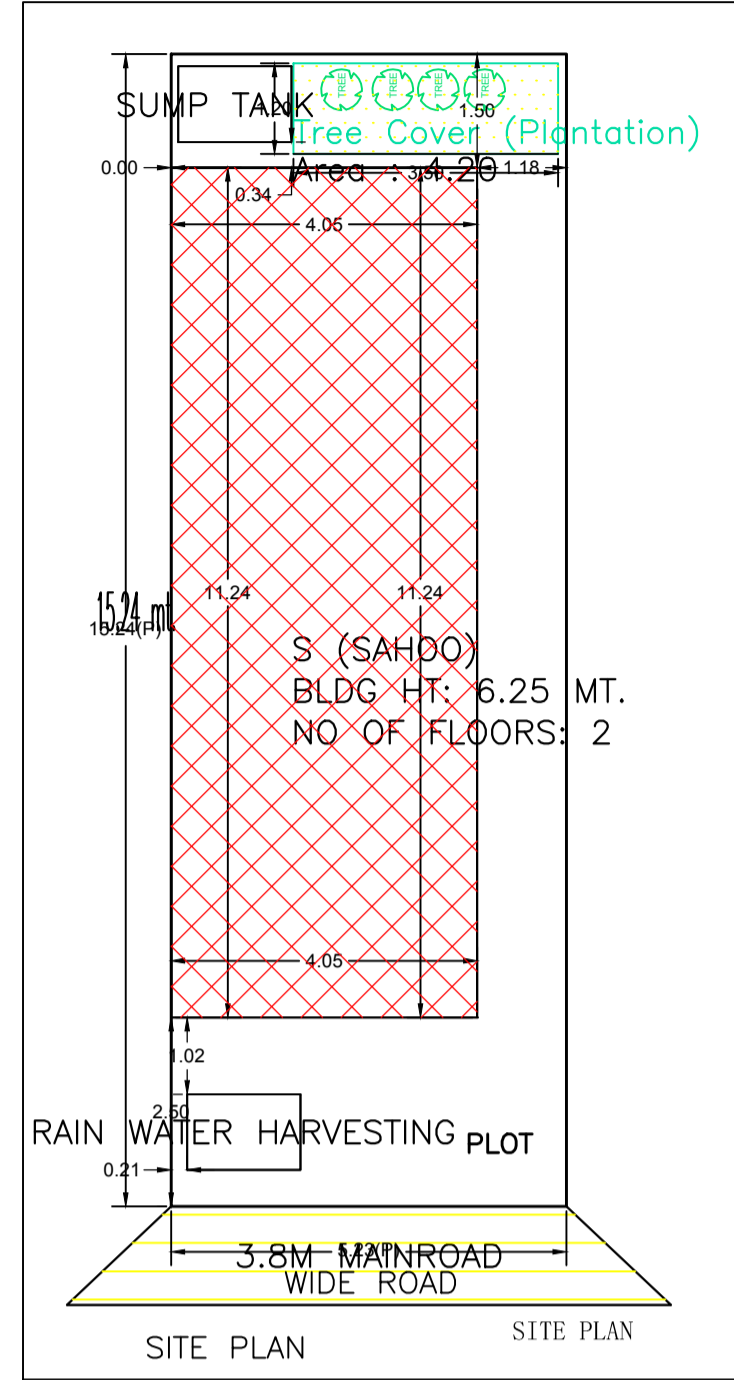
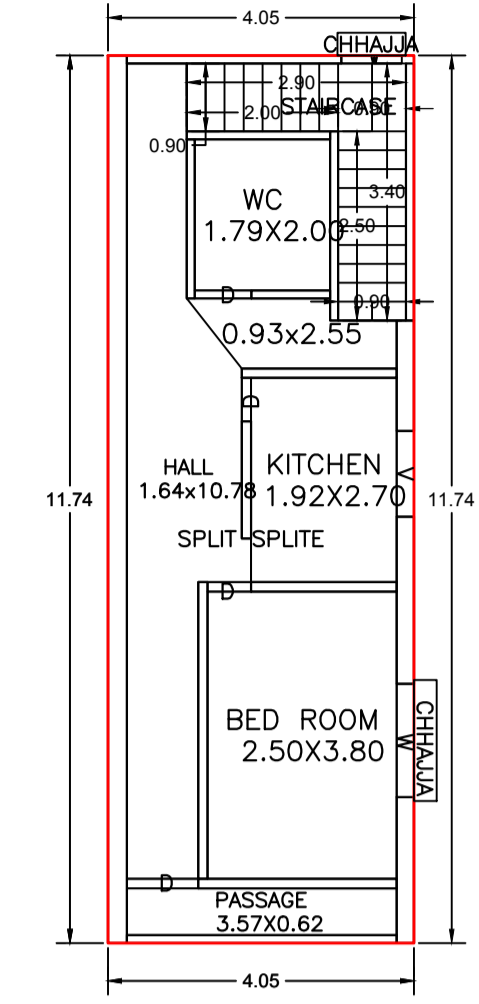

FIRST FLOOR PLAN (Proposed) (SCALE 1:100)

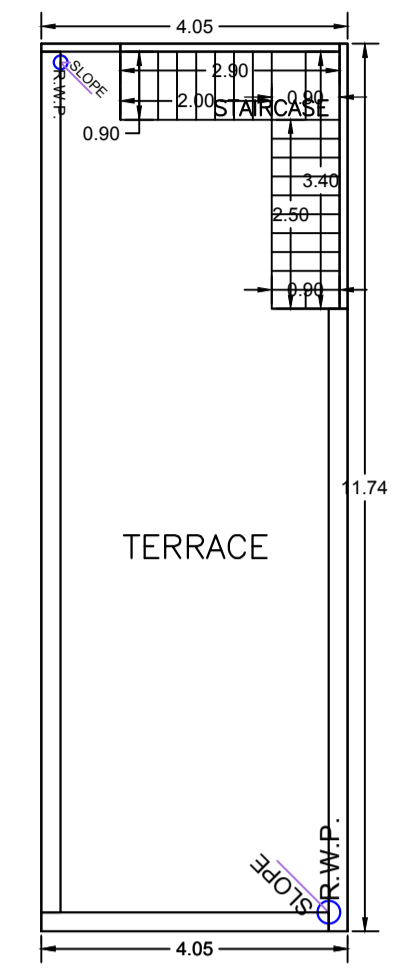

TERRACE FLOOR PLAN (SCALE 1:100)

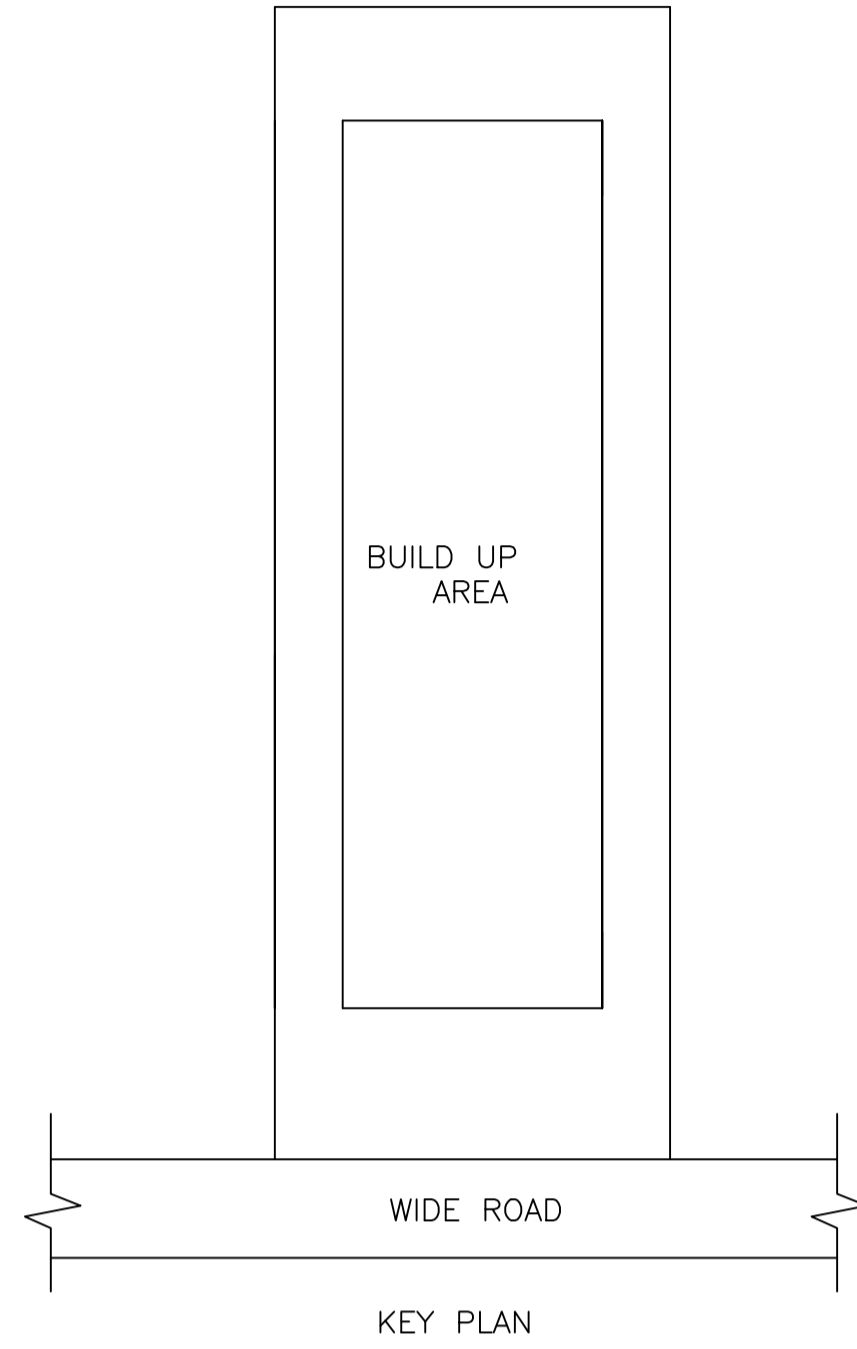

KEY PLAN

Building :S (SAHOO)

Floor Name	Total Built Up Area (Sq.mt.)	Deductions (Area in Sq.mt.)	Proposed FAR Area (Sq.mt.)	Add Area In FAR (Sq.mt.)	Total FAR Area (Sq.mt.)	Total Consumed Additional FAR Area (Sq.mt.)	Trmt (No.)
Ground Floor	45.52	40.66	0.00	4.86	4.86	4.86	00
First Floor	47.55	0.00	47.55	0.00	47.55	47.55	01
Terrace Floor	0.00	0.00	0.00	0.00	0.00	0.00	00
Total :	93.07	40.66	47.55	4.86	52.41	52.41	01

SCHEDULE OF DOOR:

BUILDING NAME	NAME	LENGTH	HEIGHT	NOS
S (SAHOO)	D	0.58	2.10	02
S (SAHOO)	D	0.75	2.10	01
S (SAHOO)	D	0.95	2.10	01

SCHEDULE OF WINDOW/VENTILATION:

BUILDING NAME	NAME	LENGTH	HEIGHT	NOS
S (SAHOO)	W	0.80	1.20	02
S (SAHOO)	V	1.13	1.20	01
S (SAHOO)	W	1.50	1.20	01

UnitBUA Table for Building :S (SAHOO)

FLOOR	Name	UnitBUA Type	UnitBUA Area	Carpet Area	No. of Rooms	No. of Tenement
FIRST FLOOR PLAN	SPLIT SPLITE	FLAT	36.73	34.43	5	1
Total:	-	-	36.73	34.43	5	1

AREA STATEMENT	VERSION NO.: 1.0.69	SQ.MT.
CHAKULIA NAGAR PANCHAYAT	VERSION DATE: 16/10/2020	79.74
PROJECT DETAIL:		
Region: JHARKHAND URBAN LOCAL BODIES	Plot Use: Residential	
District: EAST SINGHBHUM	Plot SubUse: Bungalow/ Dwelling / Non Apartment	
Authority: CHAKULIA NAGAR PANCHAYAT	PlotNearby/ReligiousStructure: NA	
Inward No: CNPCBP/0014/W/10/2023	Plot/SubPlot No: 284	
Application Type: General Proposal	North: Road Width - 3.8	
Project Type: Building Permission	South: -	
Nature of Development: New	East: -	
Location of Development Area: Old Area	West: -	
AREA DETAILS:		
AREA OF PLOT (Minimum)	(A)	79.74
NET AREA OF PLOT(Gross Plot Area - Deduction from Gross Plot area)	(A-Deductions)	79.74
Deduction for Balance Plot Area(from Gross Plot Area)		
Common Plot		4.20
Total		4.20
BALANCE AREA OF PLOT(Net Plot Area - Recreational/Amenity space)	(A-Deductions)	75.54
PLOT AREA FOR COVERAGE(Net Plot Area)	(A-Deductions)	79.74
Plot Area for FAR (Net Plot Area + RoadWidening Area)	(A-Deductions)	79.74
COVERAGE CHECK		
Permissible Coverage area (70.00 %)		55.82
Proposed Coverage Area (57.09 %)		45.52
Total Prop. Coverage Area (57.09 %)		45.52
Balance coverage area (12.92 %)		10.30
FAR CHECK		
Perm. FAR Area (1.500)		119.61
Total Perm. FAR area		119.61
Residential FAR		47.55
Proposed FAR Area		52.41
Total Proposed FAR Area		52.41
Consumed FAR (Factor)		0.66
Balance FAR Area		67.20
BUILT UP AREA CHECK		
Total Proposed BuiltUp Area		93.07
ARCHITECT (Regd)	MD WAQAR YOUNUS	
ENGINEER (Regd)		
SUPERVISOR (Regd)		
OWNER (Regd)	SUCHETA SAHOO	
DEVELOPMENT AUTHORITY	LOCAL BODY	

COLOR INDEX	
PLOT BOUNDARY	Black
ABUTTING ROAD	Red
PROPOSED CONSTRUCTION	Green
COMMON PLOT	Yellow
ROAD WIDENING AREA	Blue
EXISTING (To be retained)	Orange
EXISTING (To be demolished)	Light Blue

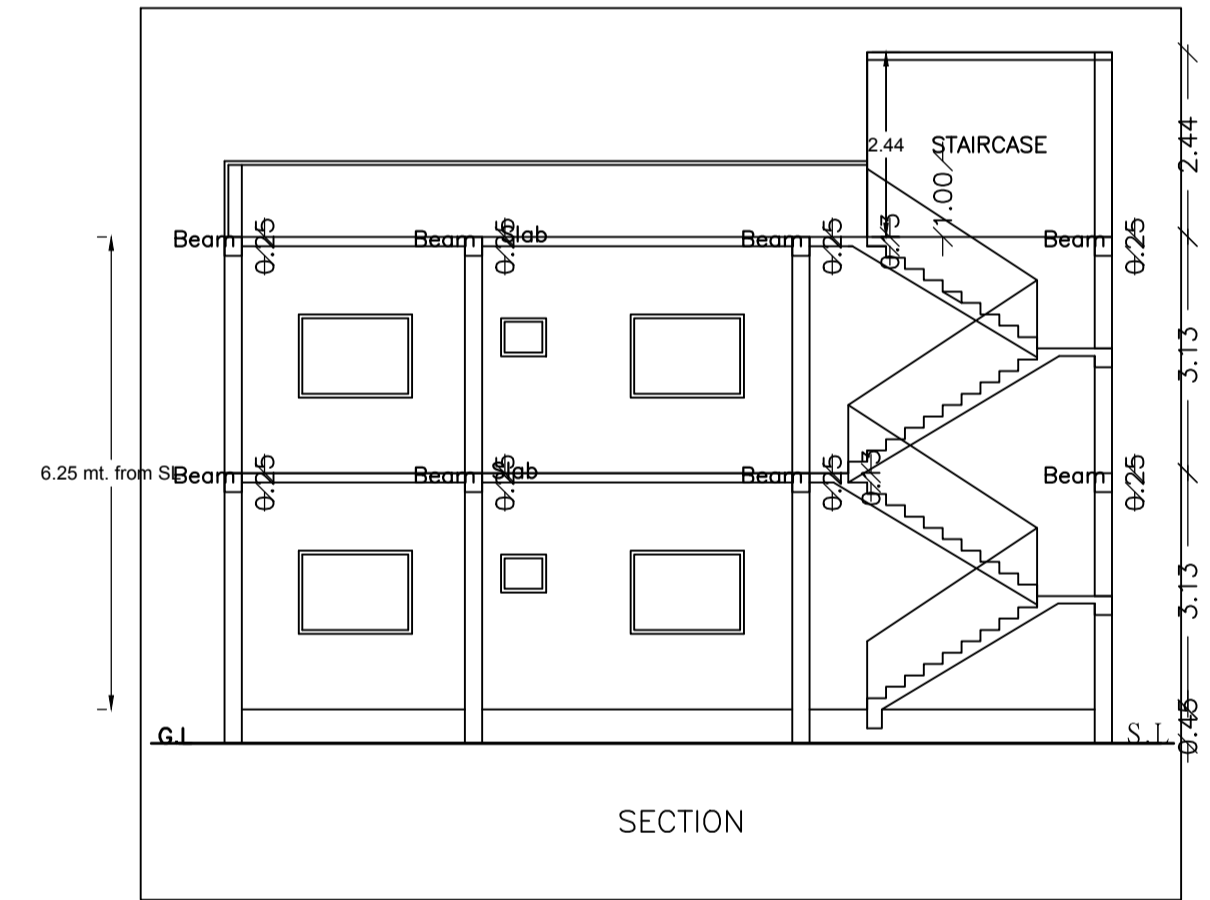

SECTION

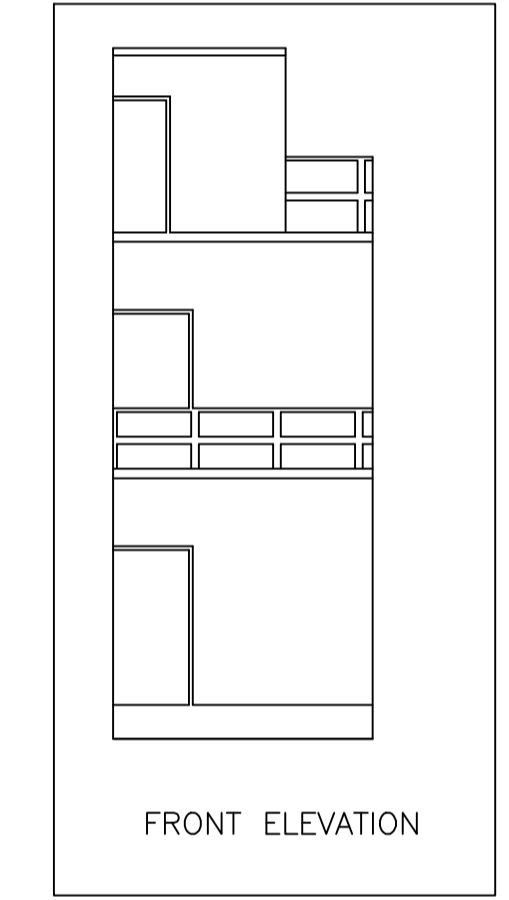

FRONT ELEVATION

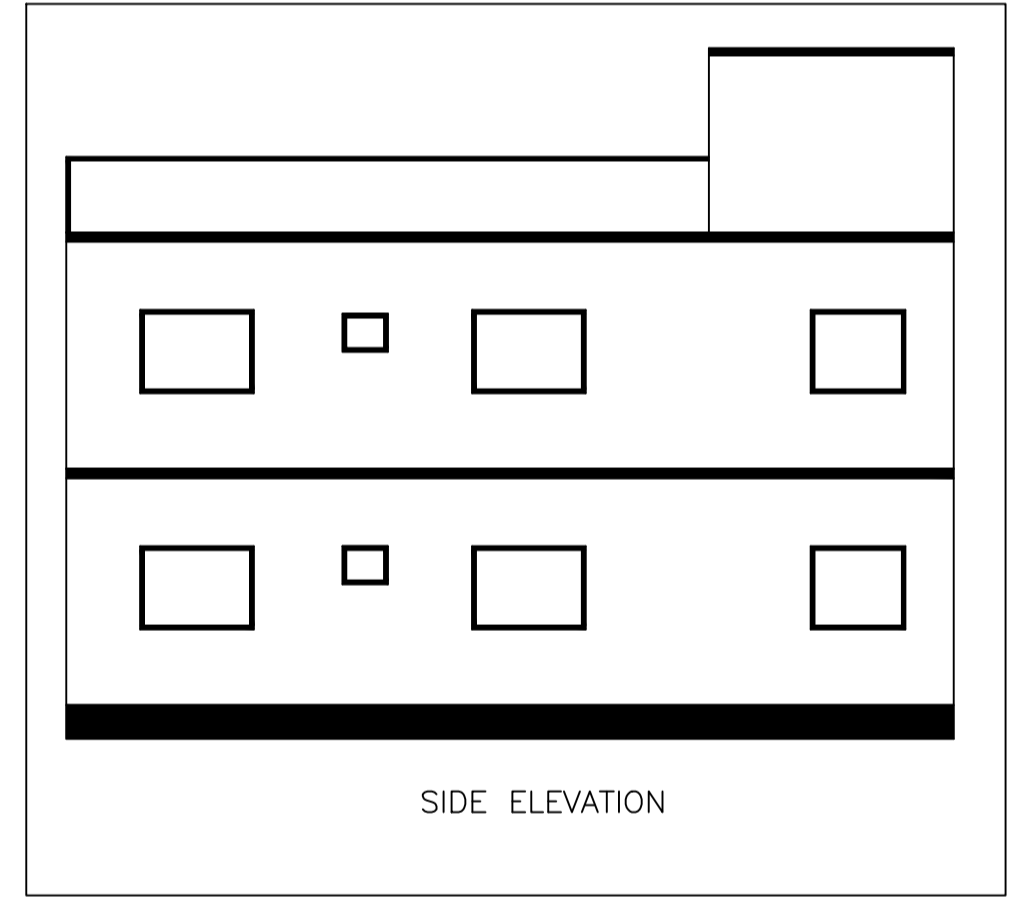

SIDE ELEVATION

Buildingwise Floor FAR Details

Floor Name	Building Name S (SAHOO)		Total	
	Proposed Built Up Area (Sq.mt.)	Proposed FAR Area (Sq.mt.)	Total Proposed Built Up Area (Sq.mt.)	Total FAR Area (Sq.mt.)
Ground Floor	45.52	4.86	45.52	4.86
First Floor	47.55	47.55	47.55	47.55
Terrace Floor	0.00	0.00	0.00	0.00
Total :	93.07	52.41	93.07	52.41

Building USE/SUBUSE Details

Building Name	Building Use	Building SubUse	Building Structure
S (SAHOO)	Residential	Bungalow/ Dwelling / Non Apartment	Non-Highrise

FAR & Tenement Details (Table 4c-1)

Building	No. of Same Bldg	Total Built Up Area (Sq.mt.)	Deductions (Area in Sq.mt.)	Proposed FAR Area (Sq.mt.)	Add Area In FAR (Sq.mt.)	Total FAR Area (Sq.mt.)	Total Consumed Additional FAR Area (Sq.mt.)	Trmt (No.)
S (SAHOO)	1	93.07	40.66	47.55	4.86	52.41	52.41	01
Grand Total :	1	93.07	40.66	47.55	4.86	52.41	52.41	01

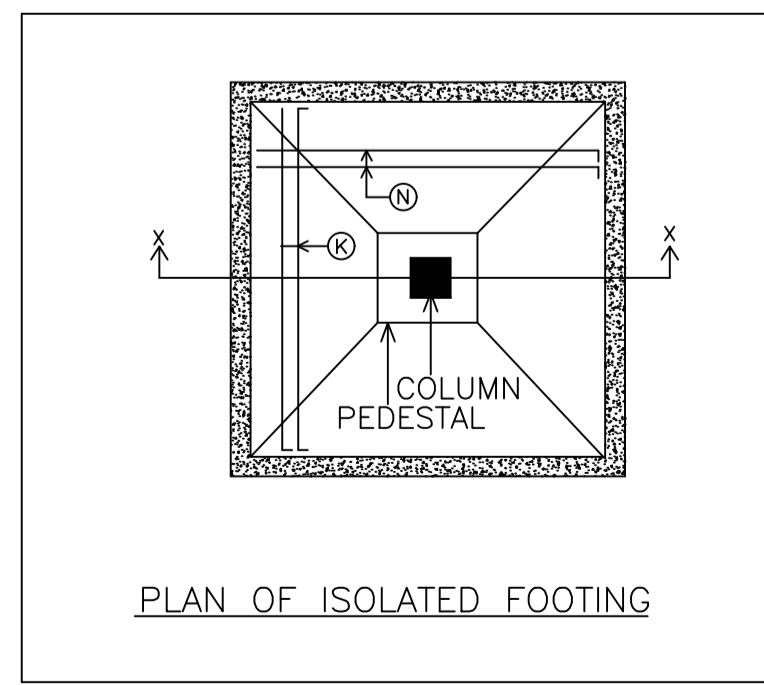

PLAN OF ISOLATED FOOTING

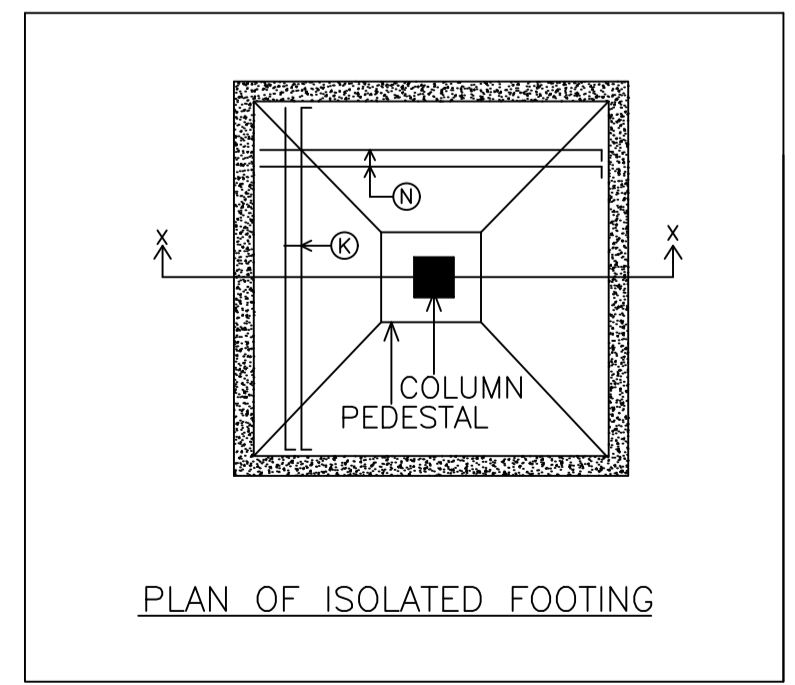

PLAN OF ISOLATED FOOTING

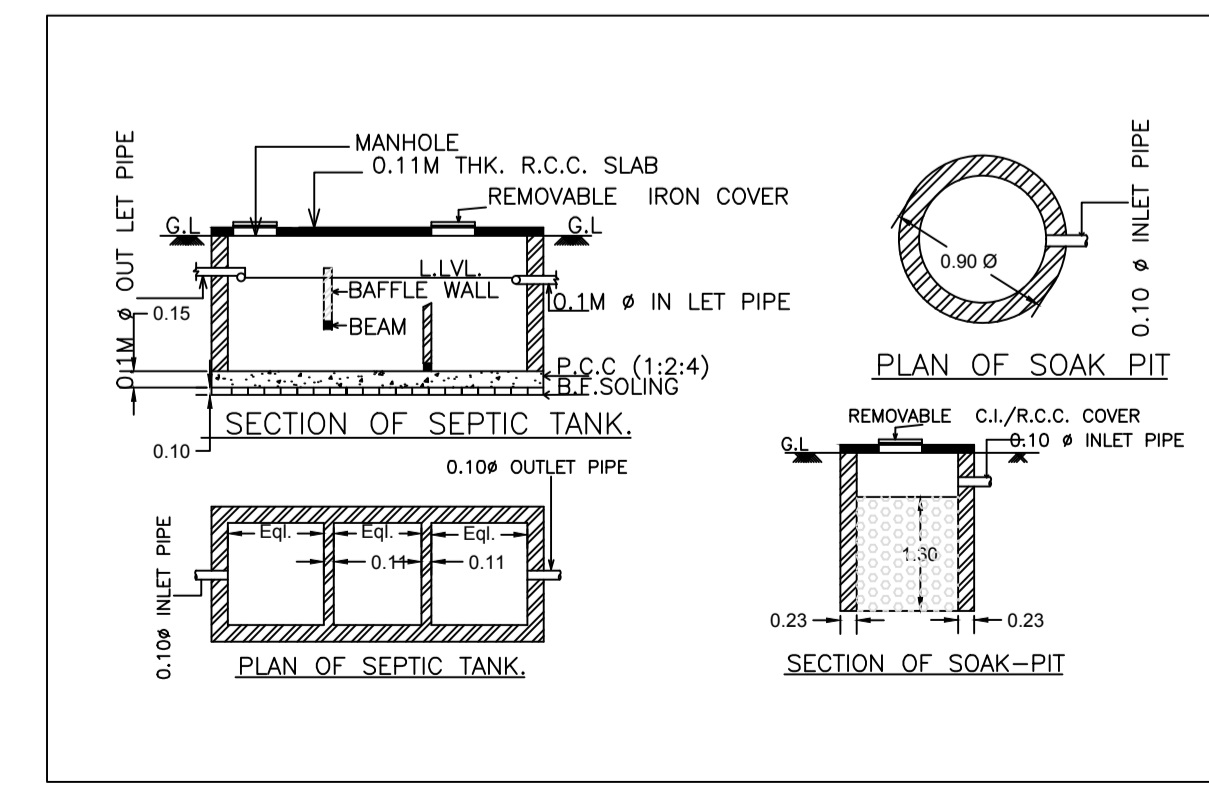

SECTION OF SEPTIC TANK

PLAN OF SEPTIC TANK

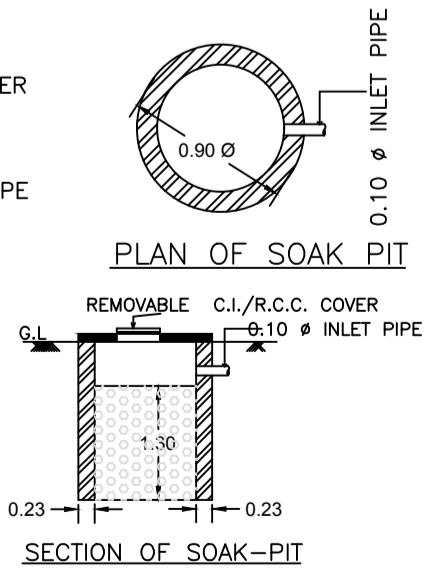

PLAN OF SOAK PIT

SECTION OF SOAK-PIT

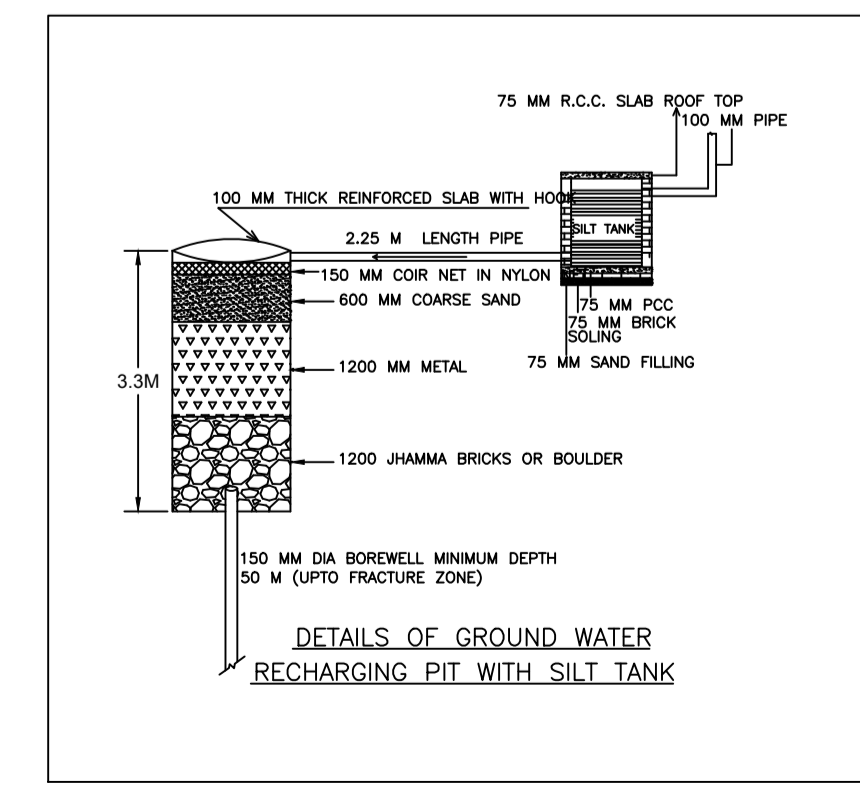

DETAILS OF GROUND WATER RECHARGING PIT WITH SILT TANK

LTP NAME AND SIGNATURE	STRUCTURAL ENG'S NAME AND SIGNATURE	BUILDER NAME AND SIGNATURE	DIGITAL SIGNATURE
MD WAQAR YOUNUS CNPC/ENG/0004/2022			