

Proposal Basic Information	
Proposal File No.	GNPC/BP/0074/W/17/2018
Owner Name	JAYANT KUMAR KESHRI
Khata No	246
Plot No	1040,1041
Village Name	Garhwa Bajar
Use	Commercial
SubUse	Shop

COLOR INDEX	
PLOT BOUNDARY	Black
ABUTTING ROAD	Green
PROPOSED CONSTRUCTION	Red
COMMON PLOT	Yellow
ROAD WIDENING AREA	Orange
EXISTING (To be retained)	Blue
EXISTING (To be demolished)	Light Blue

FAR & Tenement Details (Table 4c-1)

Building	No. of Same Bldg	Total Built Up Area (Sq.mt.)	Proposed FAR Area (Sq.mt.) Commercial	Total FAR Area (Sq.mt.)	Total Consumed Additional FAR Area (Sq.mt.)
A (BUILDING)	1	225.94	225.94	225.94	225.94
Grand Total :	1	225.94	225.94	225.94	225.94

Required Parking (Table 7a)

Building Name	Type	SubUse	Area (Sq.mt.)	Units		Car		TwoWheeler	
				Reqd.	Prop.	Reqd./Unit	Prop.	Reqd./Unit	Prop.
A (BUILDING)	Commercial	Shop	>0	50	208.42	1	3	-	-
			>0	50	208.42	-	-	1	9
Total :			-	-	-	-	3	4	9

Parking Check (Table 7b)

Vehicle Type	Reqd.		Prop.	
	No.	Area	No.	Area
Car	-	-	4	50.00
Total Car	3	37.50	4	50.00
TwoWheeler	9	18.00	11	22.00
Total		55.50		72.00

Building USE/SUBUSE Details

Building Name	Building Use	Building SubUse	Building Structure
A (BUILDING)	Commercial	Shop	Non-Highrise

SCHEDULE OF DOOR:

BUILDING NAME	NAME	LENGTH	HEIGHT	NOS
A (BUILDING)	D2	0.90	2.10	02
A (BUILDING)	R.S	3.75	2.10	01

SCHEDULE OF WINDOW/VENTILATION:

BUILDING NAME	NAME	LENGTH	HEIGHT	NOS
A (BUILDING)	V1	1.80	0.60	04
A (BUILDING)	W1	1.80	1.20	05

Building :A (BUILDING)

Floor Name	Total Built Up Area (Sq.mt.)	Proposed FAR Area (Sq.mt.) Commercial	Total FAR Area (Sq.mt.)	Total Consumed Additional FAR Area (Sq.mt.)
Ground Floor	112.97	112.97	112.97	112.97
First Floor	112.97	112.97	112.97	112.97
Terrace Floor	0.00	0.00	0.00	0.00
Total :	225.94	225.94	225.94	225.94
Total Number of Same Buildings :	1			
Total :	225.94	225.94	225.94	225.94

Buildingwise Floor FAR Details

Floor Name	Building Name A (BUILDING)		Total	
	Proposed Built Up Area (Sq.mt.)	Proposed FAR Area (Sq.mt.)	Total Proposed Built Up Area (Sq.mt.)	Total FAR Area (Sq.mt.)
Ground Floor	112.97	112.97	112.97	112.97
First Floor	112.97	112.97	112.97	112.97
Terrace Floor	0.00	0.00	0.00	0.00
Total :	225.94	225.94	225.94	225.94

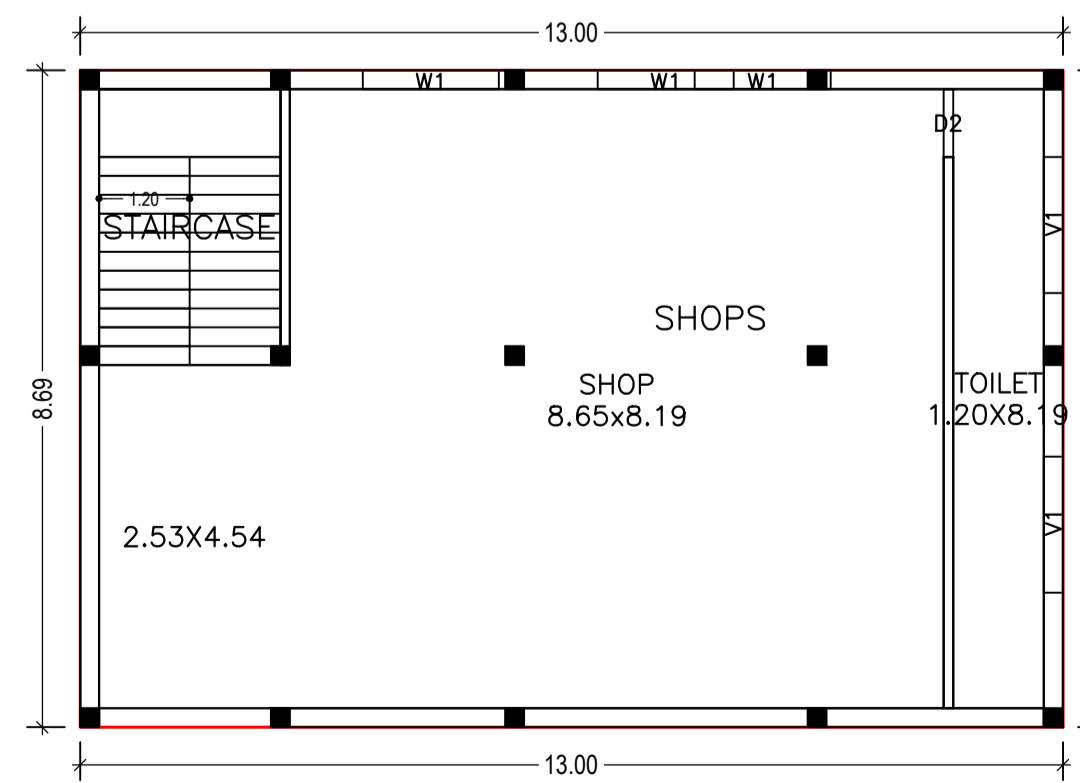
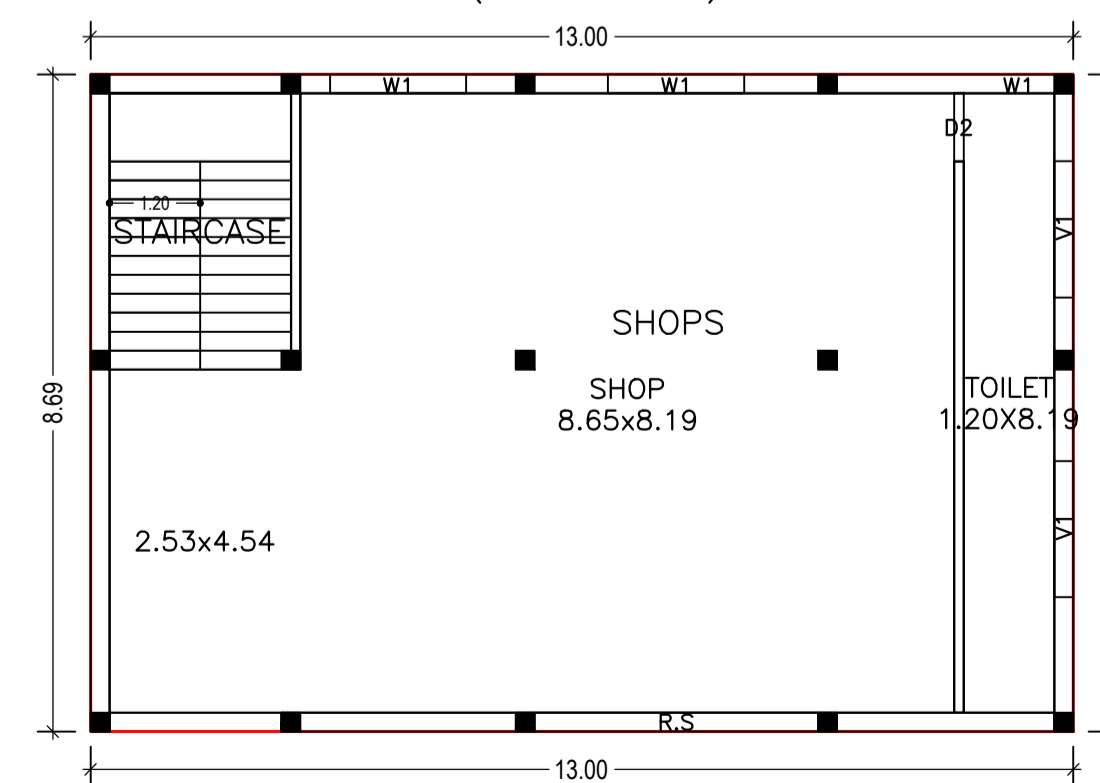
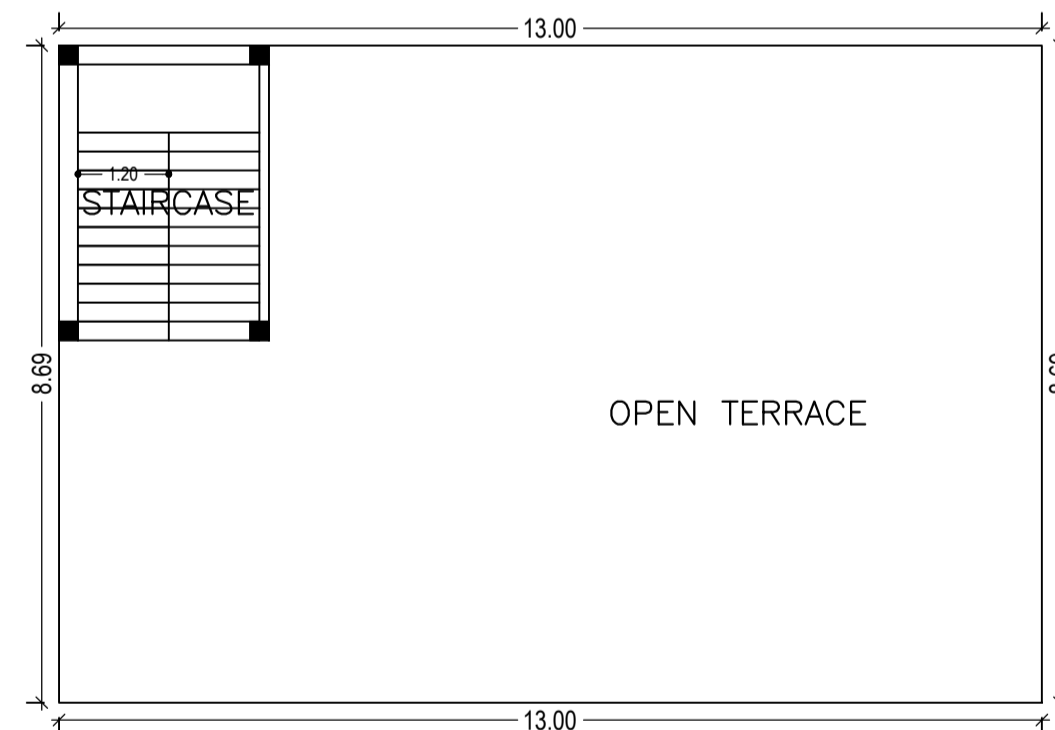
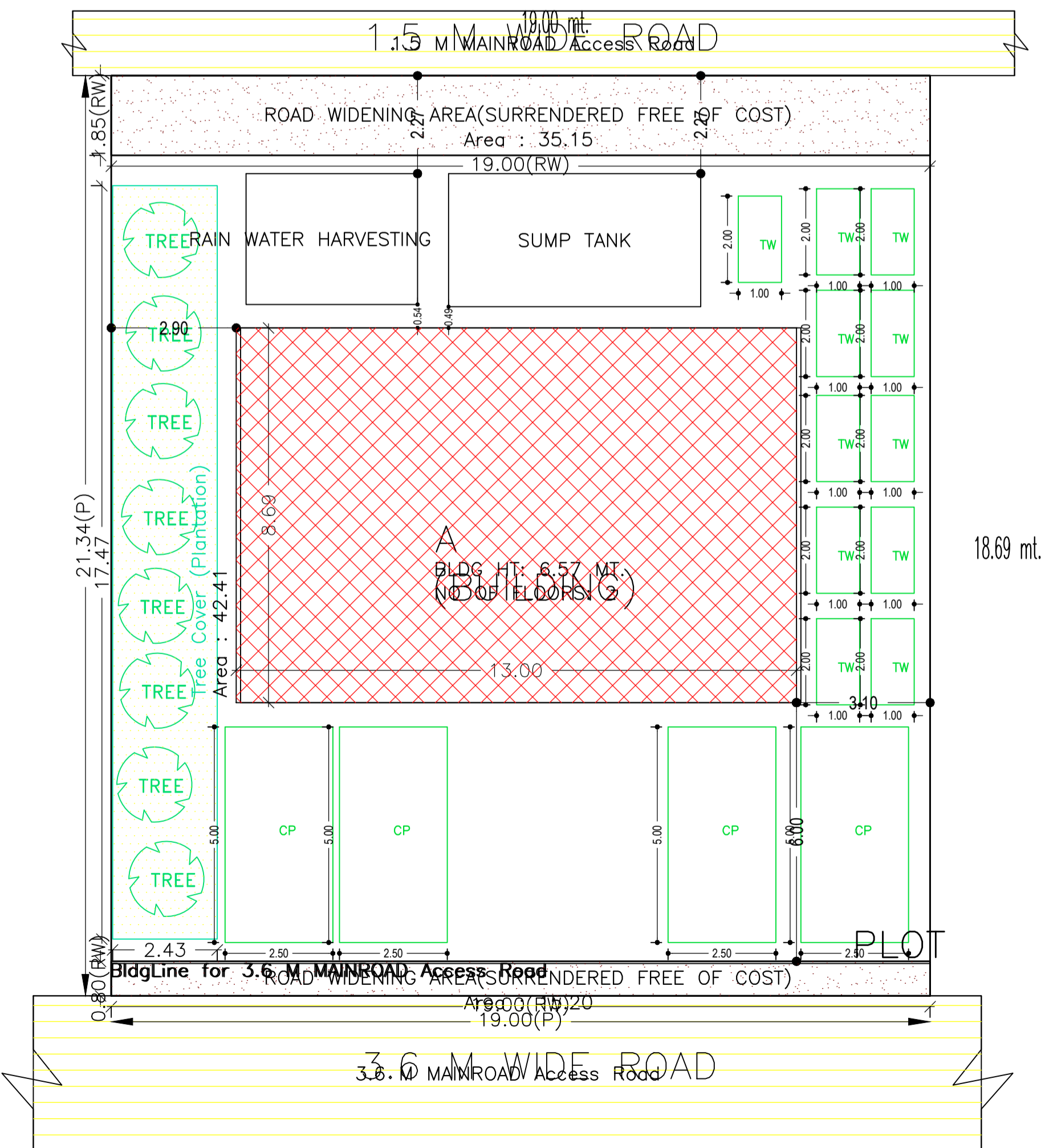

AREA STATEMENT GARHWA NAGAR PARISHAD		VERSION NO.: 1.0/30
PROJECT DETAIL:		VERSION DATE: 30/06/2018
Region : JHARKHAND URBAN LOCAL BODIES	Plot Use: Commercial	
District : GARHWA	Plot SubUse: Shop	
Authority: GARHWA NAGAR PARISHAD	Plot/Nearby/Religious/Structure: NA	
Inward No: GNPCBP/0074/W/17/2018	Plot/SubPlot No: 1040,1041	
Application Type: General Proposal	North: Road Width - 3.6	
	South: Road Width - 1.5	
	East: Plot No. - 1040,1041	
	West: Plot No. - 1040,1041	
Location of Development Area: Old Area		
AREA DETAILS:		SQ.MT.
AREA OF PLOT (Minimum)	(A)	405.46
Deduction for NetPlot Area		
Surrender Free of Cost		50.35
Total		50.35
NET AREA OF PLOT (Gross Plot Area - Deduction from Gross Plot Area)	(A-Deductions)	355.11
Deduction for Balance Plot Area (from Gross Plot Area)		
Common Plot		50.35
Total		42.41
BALANCE AREA OF PLOT (Net Plot Area - Recreational/Amenity space)	(A-Deductions)	312.70
PLOT AREA FOR COVERAGE (Net Plot Area)	(A-Deductions)	355.11
Plot Area for FAR (Net Plot Area + Road Widening Area)	(A-Deductions)	405.46
COVERAGE CHECK		
Permissible Coverage area ( 50.00 % )		177.55
Proposed Coverage Area ( 31.81 % )		112.97
Total Prop. Coverage Area ( 31.81 % )		112.97
Balance coverage area ( 18.19 % )		64.58
FAR CHECK		
Perm. FAR Area ( 2.00 )		810.92
Total Perm. FAR area		810.92
Commercial FAR		225.94
Proposed FAR Area		225.94
Total Proposed FAR Area		225.94
Consumed FAR (Factor)		0.56
Balance FAR Area		584.98
BUILT UP AREA CHECK		
Total Proposed BuiltUp Area		225.94
ARCHITECT (Regd)	RESHAN ALI	
ENGINEER (Regd)		
SUPERVISOR (Regd)		
OWNER (Regd)	JAYANT KUMAR KESHRI	
DEVELOPMENT AUTHORITY	LOCAL BODY	

LTP NAME AND SIGNATURE	STRUCTURAL ENG'S NAME AND SIGNATURE	BUILDER NAME AND SIGNATURE	DIGITAL SIGNATURE
RESHAN ALI GNPC/ENG/0005/2017			

Proposal Basic Information	
Proposal File No.	GNPC/BP/0074/W17/2018
Owner Name	JAYANT KUMAR KESHRI
Khata No	246
Plot No	1040,1041
Village Name	Garhwa Bajar
Use	Commercial
SubUse	Shop

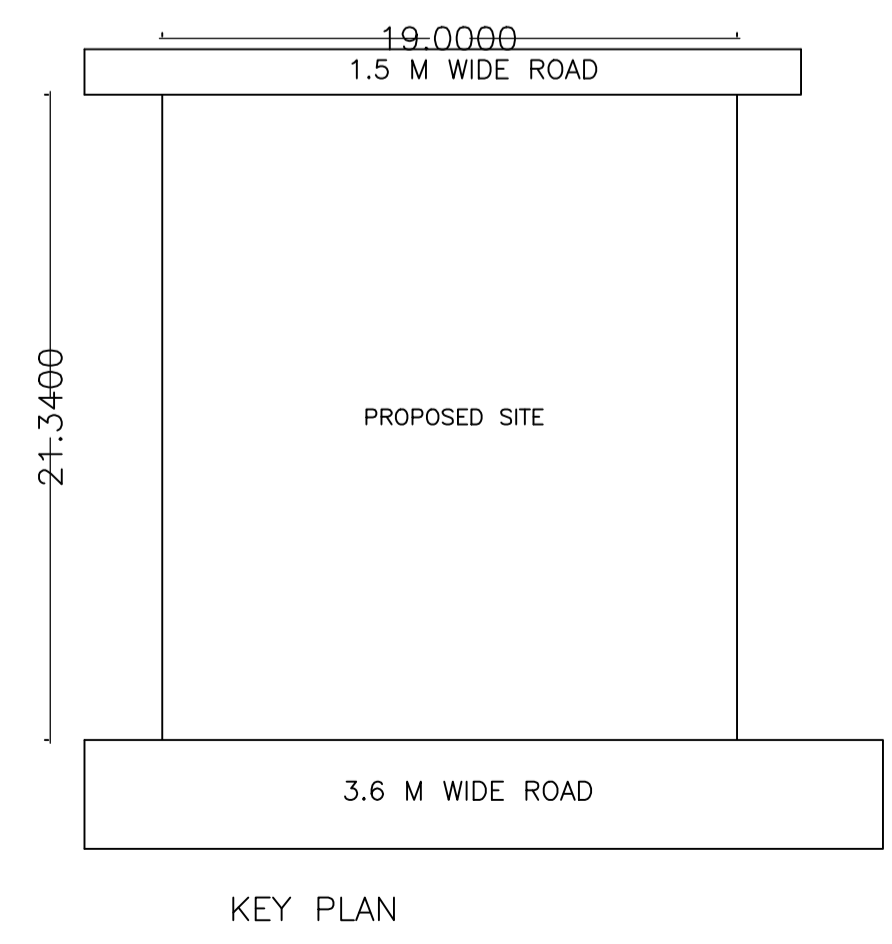
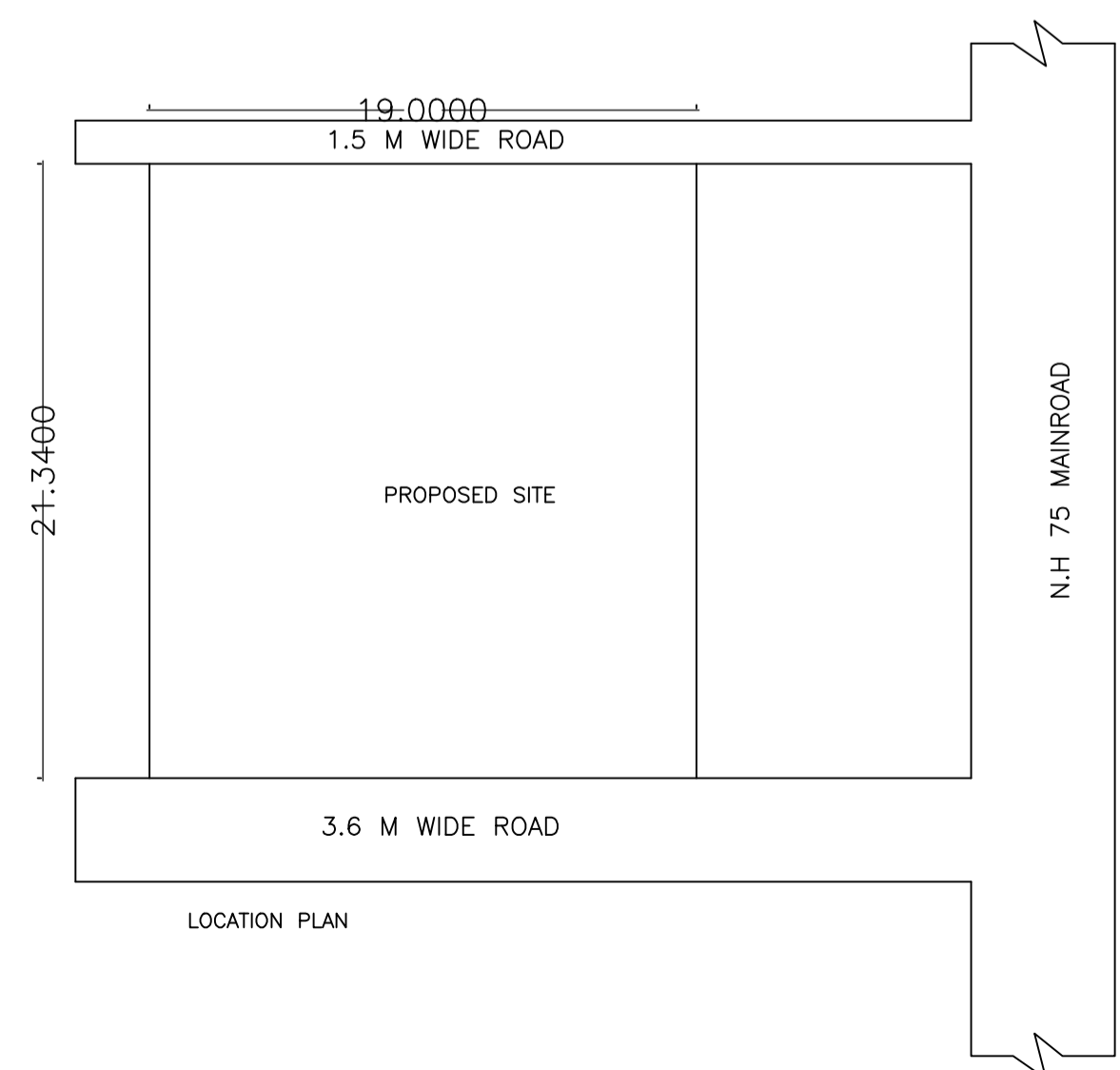
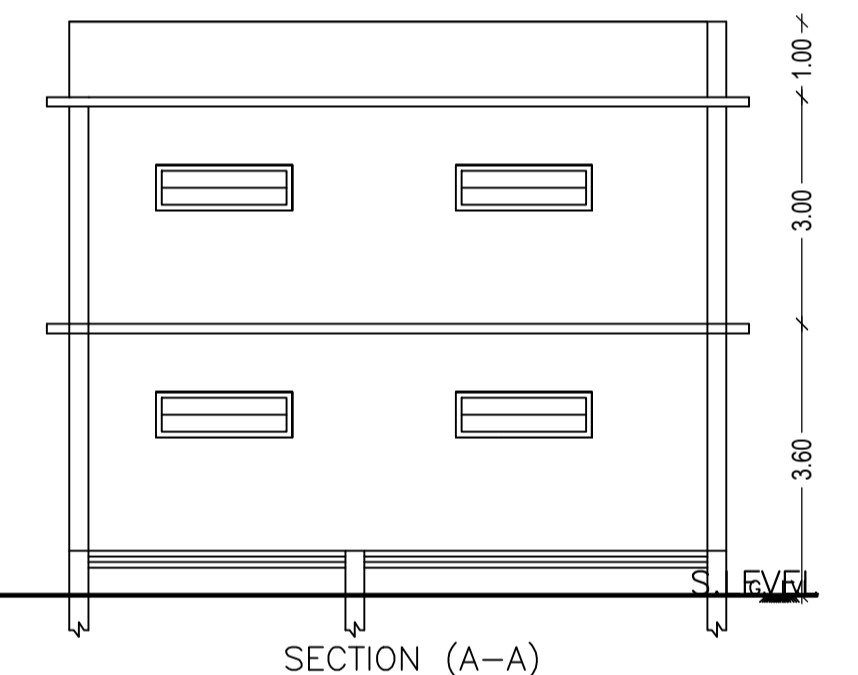
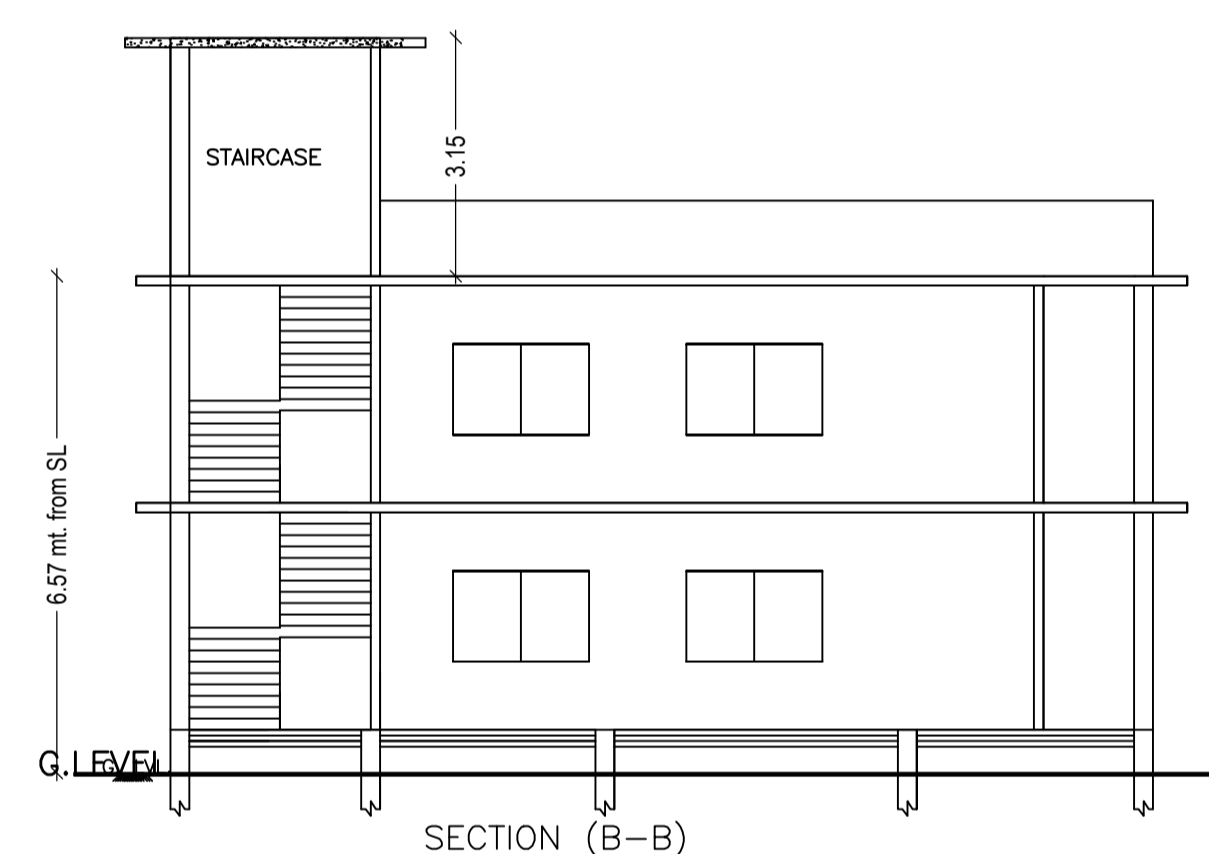
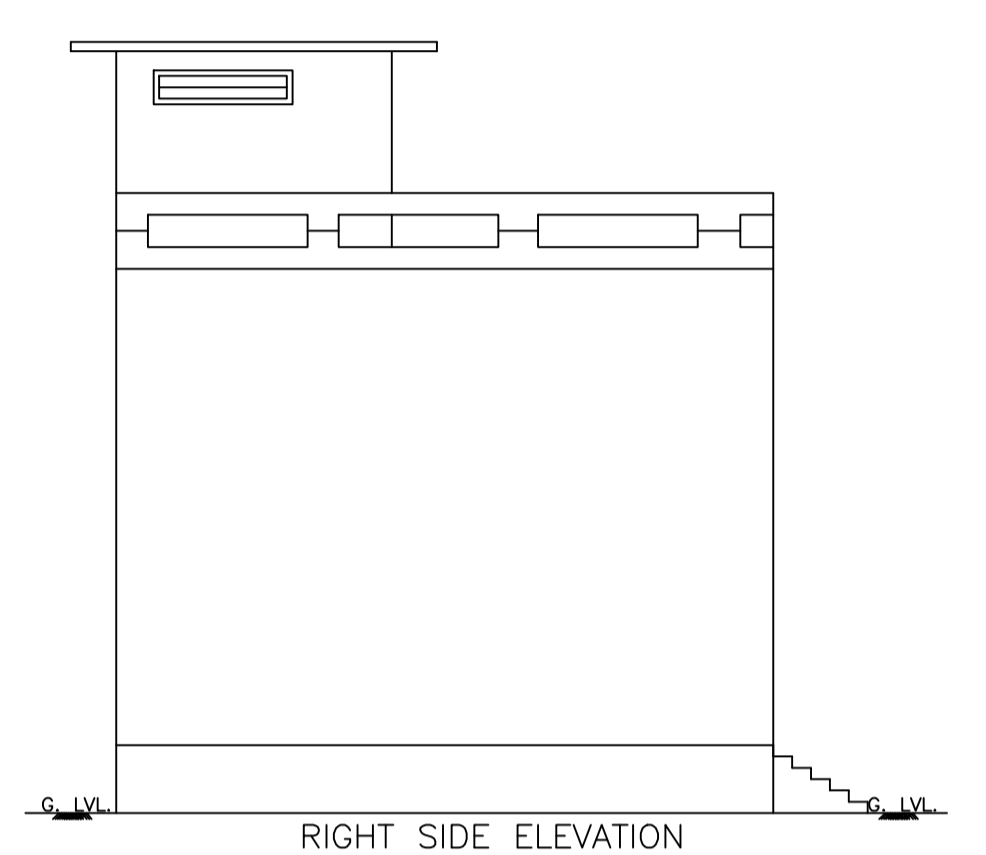
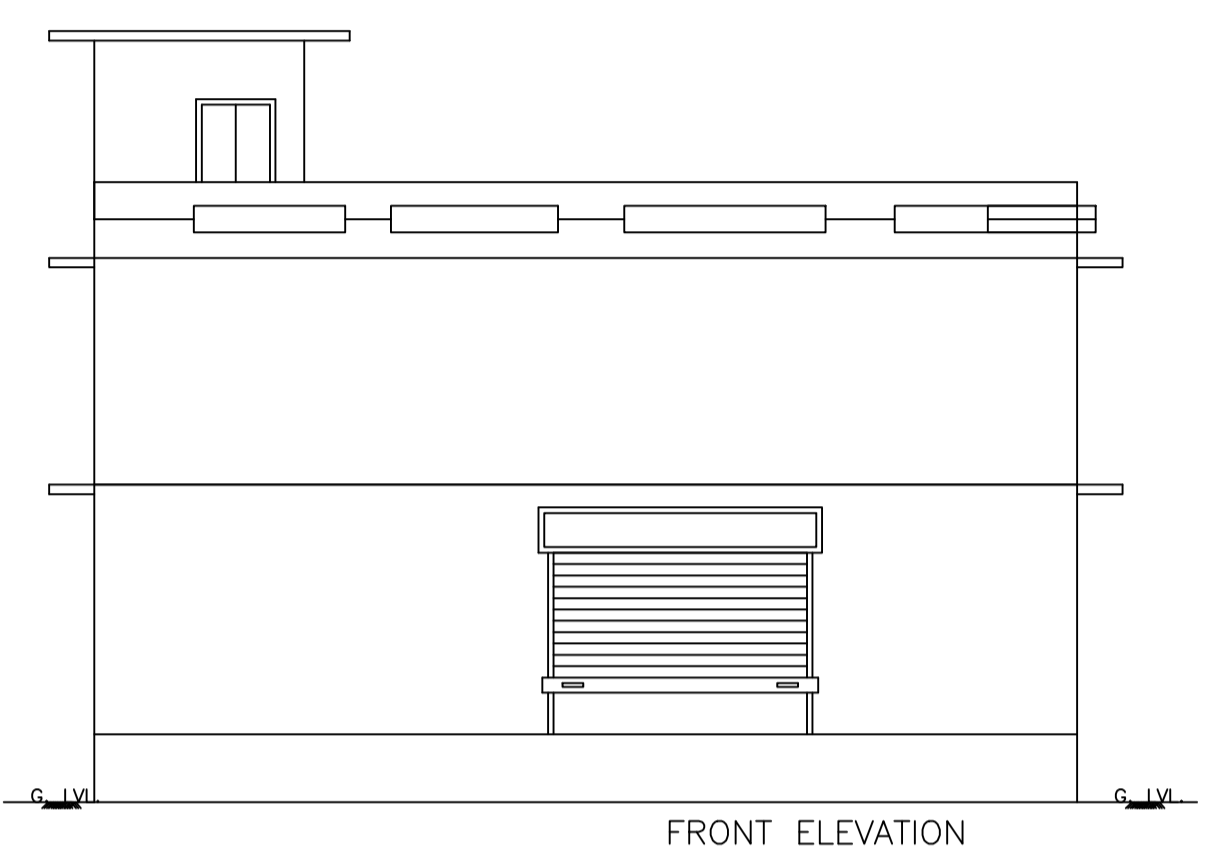
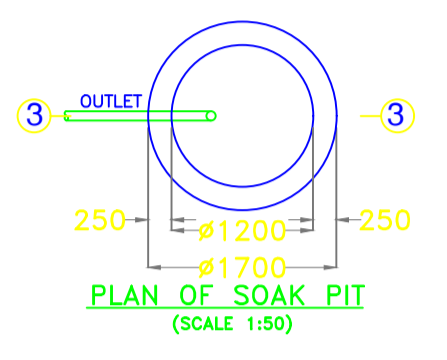
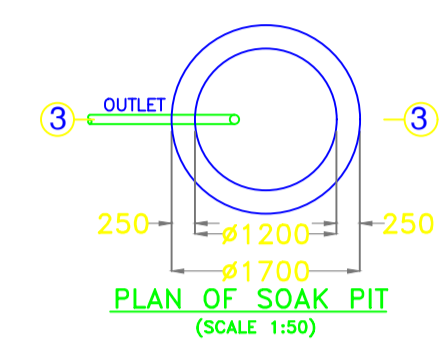
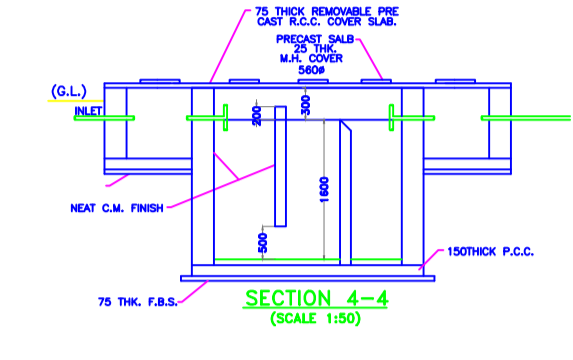
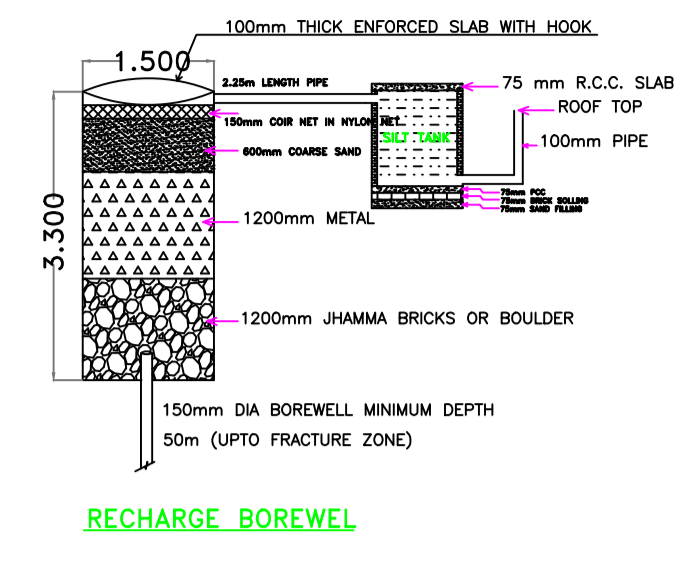
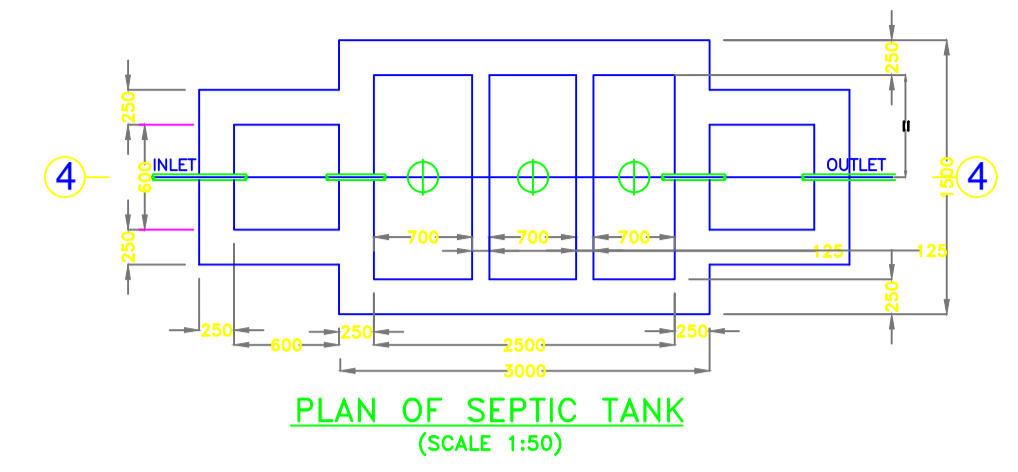

UnitBUA Table for Building :A (BUILDING)

FLOOR	Name	UnitBUA Type	UnitBUA Area	Carpet Area	No. of Rooms	No. of Tenement
GROUND FLOOR PLAN	SHOPS	OFFICE	112.97	101.01	2	1
FIRST FLOOR PLAN	SHOPS	OFFICE	112.97	101.01	2	1
Total:	-	-	225.94	202.02	4	2

LTP NAME AND SIGNATURE	STRUCTURAL ENG'S NAME AND SIGNATURE	BUILDER NAME AND SIGNATURE	DIGITAL SIGNATURE
RESHAN ALI GNPC/ENG/0005/2017			