

Proposal Basic Information

Proposal File No.	GNPC/BP/0102/W08/2018
Owner Name	SMT ASHA DEVI
Khata No	188
Plot No	574,575
Village Name	Sahijana
Use	Residential
SubUse	Bungalow/ Dwelling / Non Apartment

Buildingwise Floor FAR Details

Floor Name	Building Name A (BUILDING)		Total	
	Proposed Built Up Area (Sq.mt.)	Proposed FAR Area (Sq.mt.)	Total Proposed Built Up Area (Sq.mt.)	Total FAR Area (Sq.mt.)
Ground Floor	92.40	92.40	92.40	92.40
Terrace Floor	0.00	0.00	0.00	0.00
Total :	92.40	92.40	92.40	92.40

COLOR INDEX

PLOT BOUNDARY	Black
ABUTTING ROAD	Red
PROPOSED CONSTRUCTION	Green
COMMON PLOT	Yellow
ROAD WIDENING AREA	Orange
EXISTING (To be retained)	Blue
EXISTING (To be demolished)	Light Blue

Building :A (BUILDING)

Floor Name	Total Built Up Area (Sq.mt.)	Proposed FAR Area (Sq.mt.)		Total Consumed Additional FAR Area (Sq.mt.)	Trmt (No.)
		Resi.	Total FAR Area (Sq.mt.)		
Ground Floor	92.40	92.40	92.40	92.40	01
Terrace Floor	0.00	0.00	0.00	0.00	00
Total :	92.40	92.40	92.40	92.40	01
Total Number of Same Buildings :	1				
Total :	92.40	92.40	92.40	92.40	01

SCHEDULE OF DOOR:

BUILDING NAME	NAME	LENGTH	HEIGHT	NOS
A (BUILDING)	D2	0.75	2.10	01
A (BUILDING)	D1	1.00	2.10	05
A (BUILDING)	D	1.05	2.10	01

SCHEDULE OF WINDOW/VENTILATION:

BUILDING NAME	NAME	LENGTH	HEIGHT	NOS
A (BUILDING)	V1	0.60	1.20	01
A (BUILDING)	W1	1.80	1.20	08

FAR & Tenement Details (Table 4c-1)

Building	No. of Same Bldg	Total Built Up Area (Sq.mt.)	Proposed FAR Area (Sq.mt.) Resi.	Total FAR Area (Sq.mt.)	Total Consumed Additional FAR Area (Sq.mt.)	Trmt (No.)
A (BUILDING)	1	92.40	92.40	92.40	92.40	01
Grand Total :	1	92.40	92.40	92.40	92.40	01

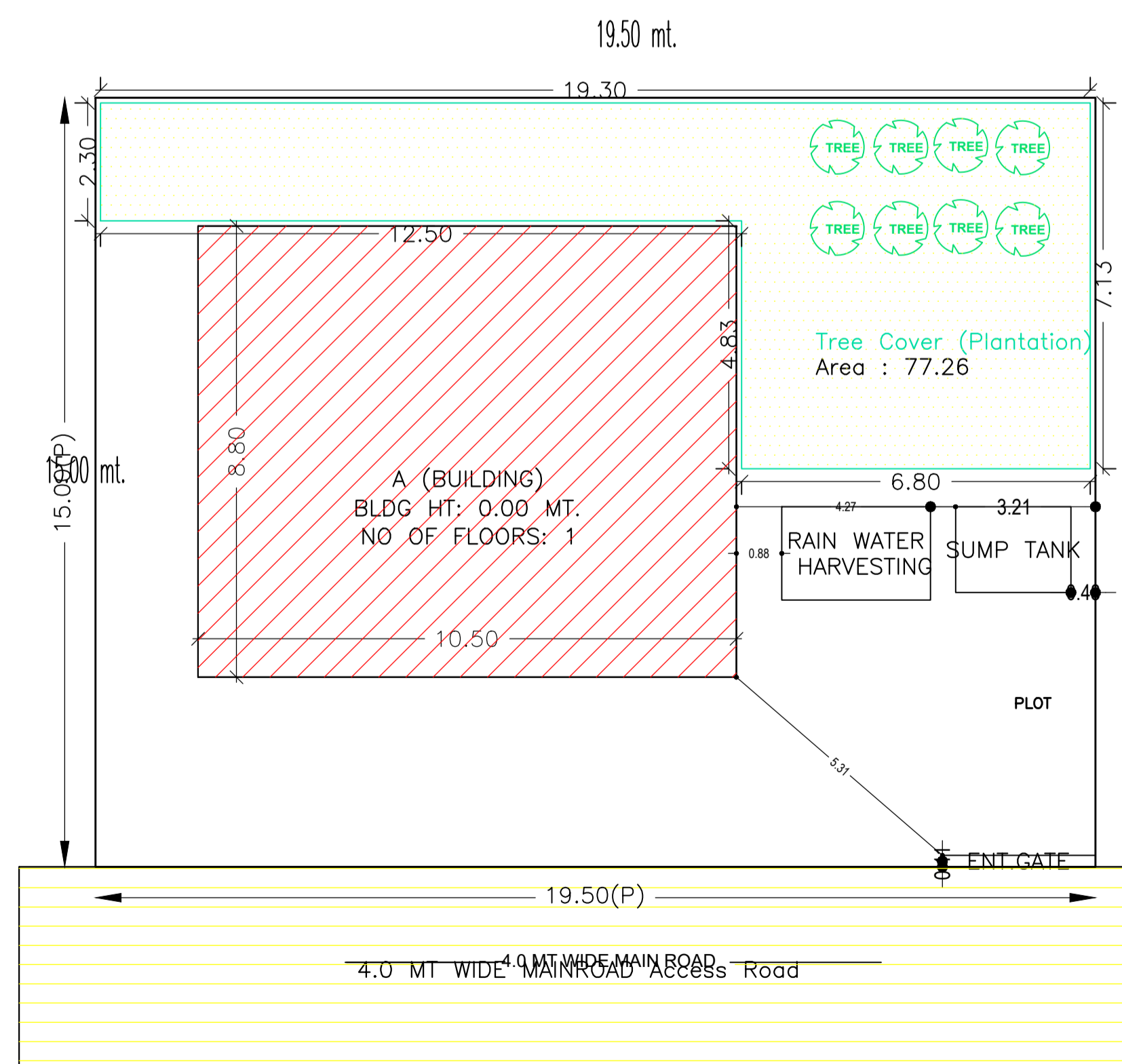
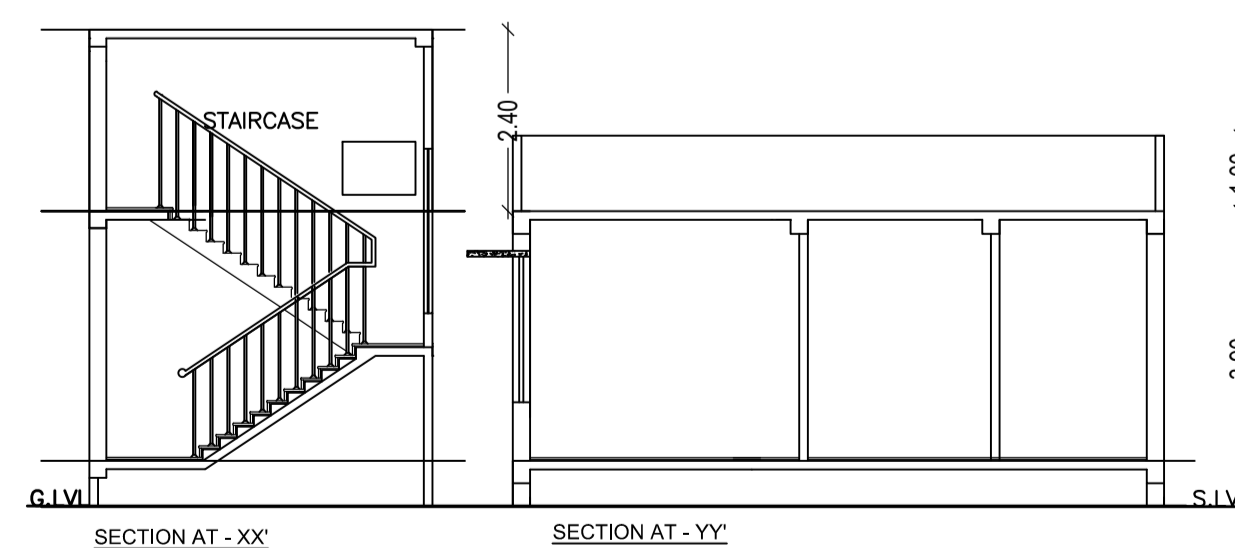
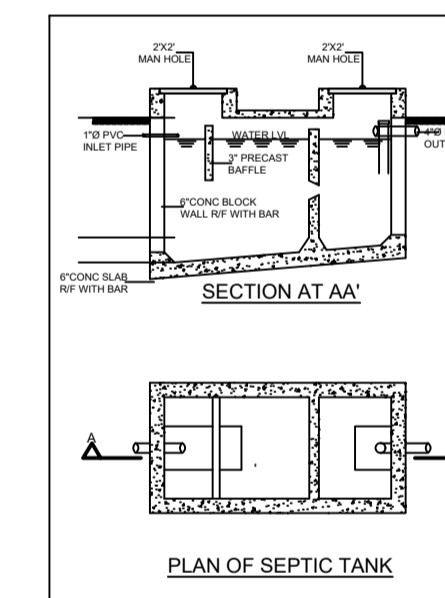
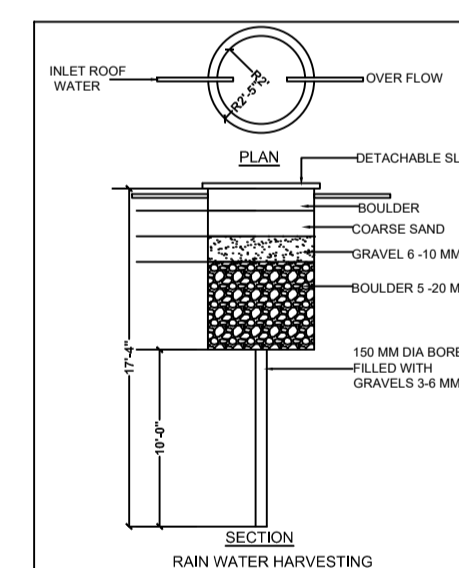
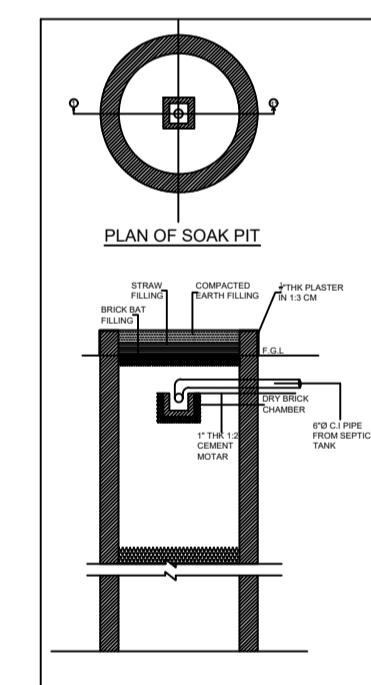
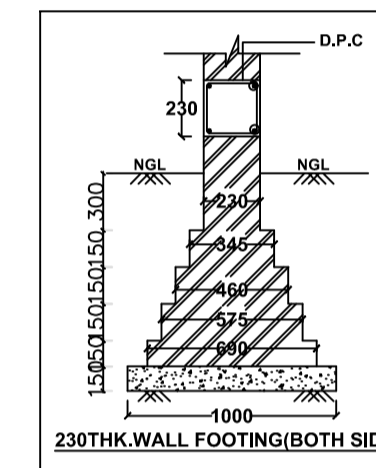
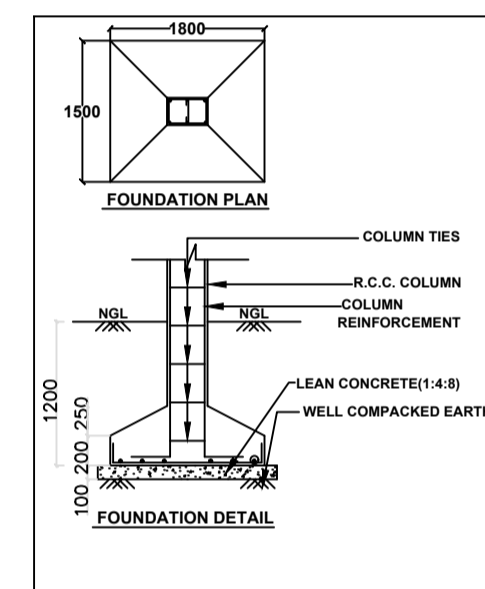
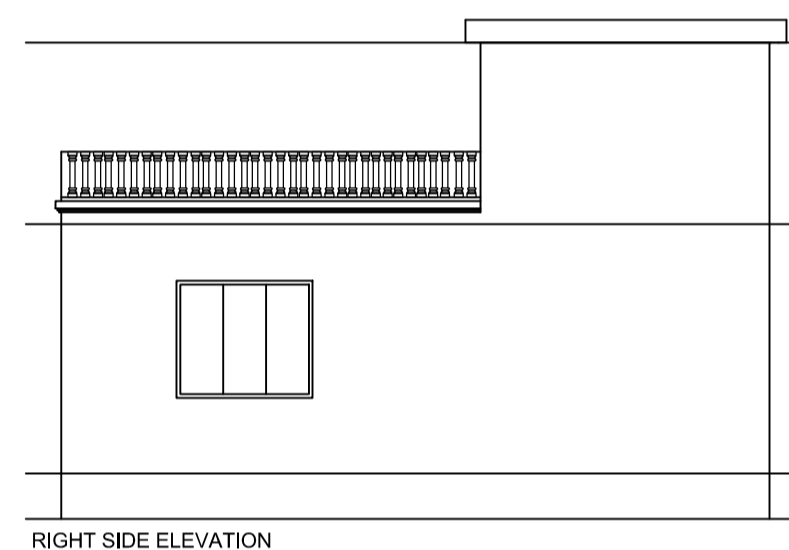
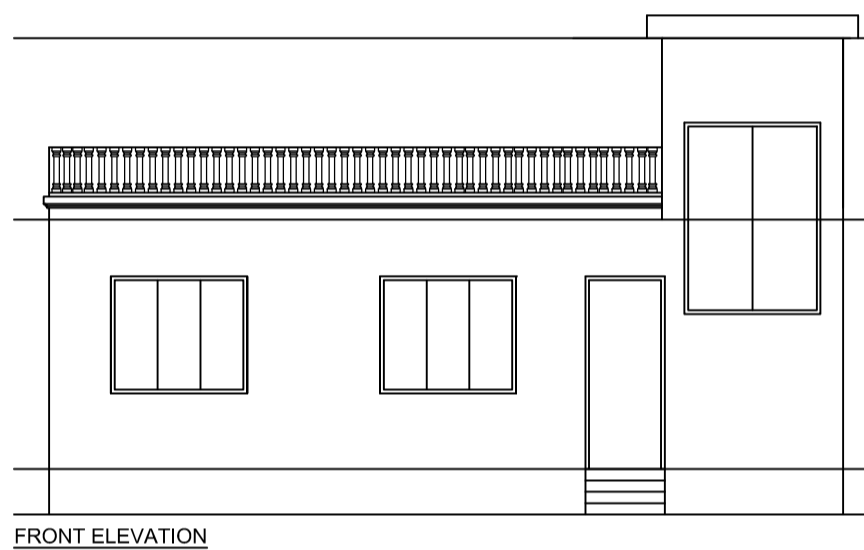
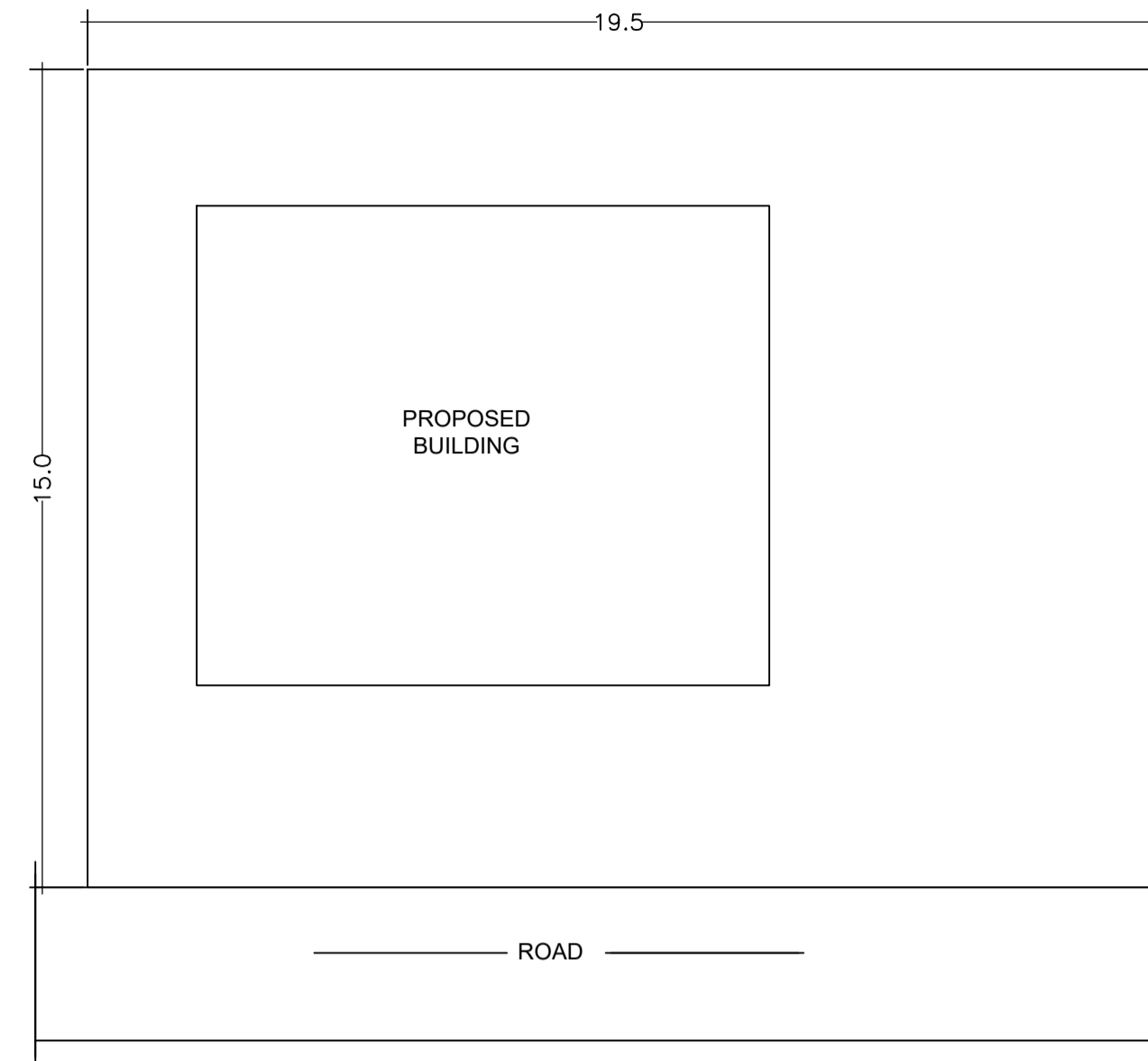
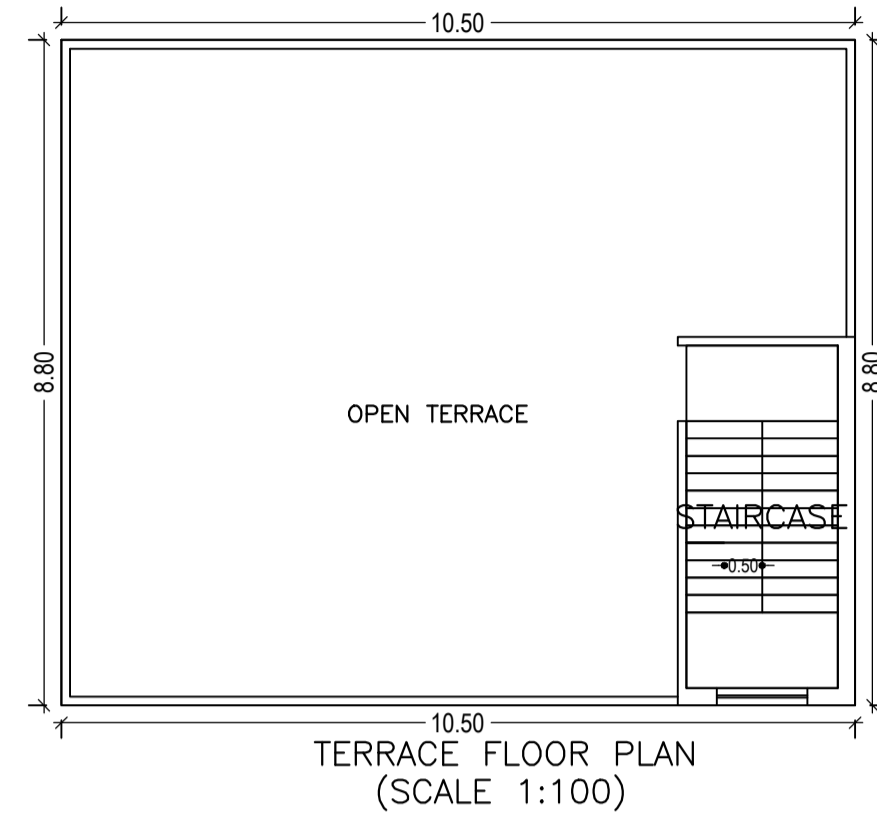
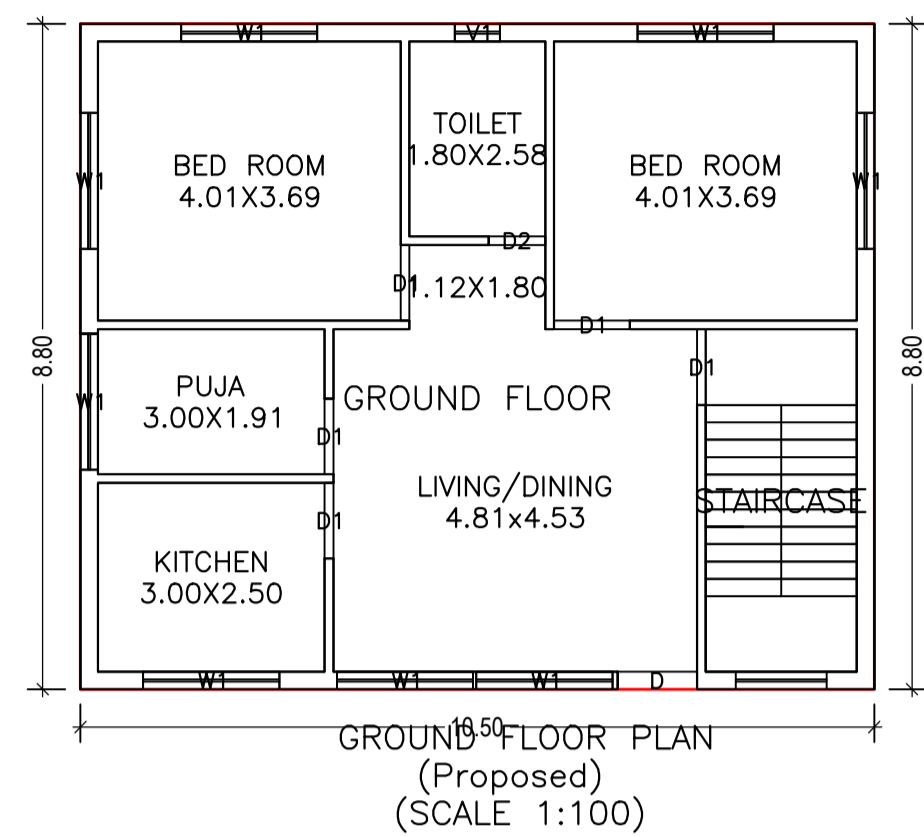

SITE PLAN

UnitBUA Table for Building :A (BUILDING)

FLOOR	Name	UnitBUA Type	UnitBUA Area	Carpet Area	No. of Rooms	No. of Tenement
GROUND FLOOR	GROUND FLOOR	FLAT	92.40	81.25	6	1
Total:	-	-	92.40	81.25	6	1

Building USE/SUBUSE Details

Building Name	Building Use	Building SubUse	Building Structure
A (BUILDING)	Residential	Bungalow/ Dwelling / Non Apartment	Non-Highrise

AREA STATEMENT GARHWA NAGAR PARISHAD	VERSION NO.: 1.0.31	SQ. MT.
PROJECT DETAIL:	VERSION DATE: 30/06/2018	
Region: JHARKHAND URBAN LOCAL BODIES	Plot Use: Residential	
District: GARHWA	Plot SubUse: Bungalow/ Dwelling / Non Apartment	
Authority: GARHWA NAGAR PARISHAD	PlotNearbyReligiousStructure: NA	
Inward No: GNPC/BP/0102/W08/2018	Plot/SubPlot No: 574,575	
Application Type: General Proposal	North: Road Width - 4.0	
Project Type: Building Permission	South: Plot No. - 575	
Nature of Development: New	East: Plot No. - 574	
Location of Development Area: Old Area	West: Plot No. - 574	
AREA DETAILS:		
AREA OF PLOT (Minimum)	(A)	292.50
NET AREA OF PLOT(Gross Plot Area - Deduction from Gross Plot area)	(A-Deductions)	292.50
Deduction for Balance Plot Area(from Gross Plot Area)		
Common Plot		77.26
Total		77.26
BALANCE AREA OF PLOT(Net Plot Area - Recreational/Amenity space)	(A-Deductions)	215.24
PLOT AREA FOR COVERAGE(Net Plot Area)	(A-Deductions)	292.50
Plot Area for FAR (Net Plot Area + Road/Widening Area)	(A-Deductions)	292.50
COVERAGE CHECK		
Permissible Coverage area (60.00 %)		175.50
Proposed Coverage Area (31.59 %)		92.40
Total Prop. Coverage Area (31.59 %)		92.40
Balance coverage area (28.41 %)		83.10
FAR CHECK		
Perm. FAR Area (1.50)		438.75
Total Perm. FAR area		438.75
Residential FAR		92.40
Proposed FAR Area		92.40
Total Proposed FAR Area		92.40
Consumed FAR (Factor)		0.32
Balance FAR Area		346.35
BUILT UP AREA CHECK		
Total Proposed BuiltUp Area		92.40
ARCHITECT (Regd)		PRADEEP KUNTAL KUNTAL
ENGINEER (Regd)		
SUPERVISOR (Regd)		
OWNER (Regd)		SMT ASHA DEVI
DEVELOPMENT AUTHORITY		LOCAL BODY

LTP NAME AND SIGNATURE	STRUCTURAL ENG'S NAME AND SIGNATURE	BUILDER NAME AND SIGNATURE	DIGITAL SIGNATURE
PRADEEP KUNTAL KUNTAL GNPC/ARC/0007/2017			