

Proposal Basic Information

Proposal File No.	GNPC/BP/0083/W08/2018
Owner Name	SHRI RAM AND OM SHRI KRISHNAM
Khata No	01
Plot No	657
Village Name	Sahijana
Use	Residential
SubUse	Bungalow/ Dwelling / Non Apartment

SCHEDULE OF DOOR:

BUILDING NAME	NAME	LENGTH	HEIGHT	NOS
A (BUILDING)	D2	0.75	2.10	01
A (BUILDING)	D1	1.00	2.10	04

SCHEDULE OF WINDOW/VENTILATION:

BUILDING NAME	NAME	LENGTH	HEIGHT	NOS
A (BUILDING)	V1	0.60	1.20	01
A (BUILDING)	W1	1.80	1.20	06

UnitBUA Table for Building :A (BUILDING)

FLOOR	Name	UnitBUA Type	UnitBUA Area	Carpet Area	No. of Rooms	No. of Tenement
FIRST FLOOR PLAN	NORMAL TENEMENT	FLAT	62.25	53.42	5	1
Total:	-	-	62.25	53.42	5	1

COLOR INDEX	
PLOT BOUNDARY	Black
ABUTTING ROAD	Green
PROPOSED CONSTRUCTION	Red
COMMON PLOT	Yellow
ROAD WIDENING AREA	Blue
EXISTING (To be retained)	Light Blue
EXISTING (To be demolished)	Orange

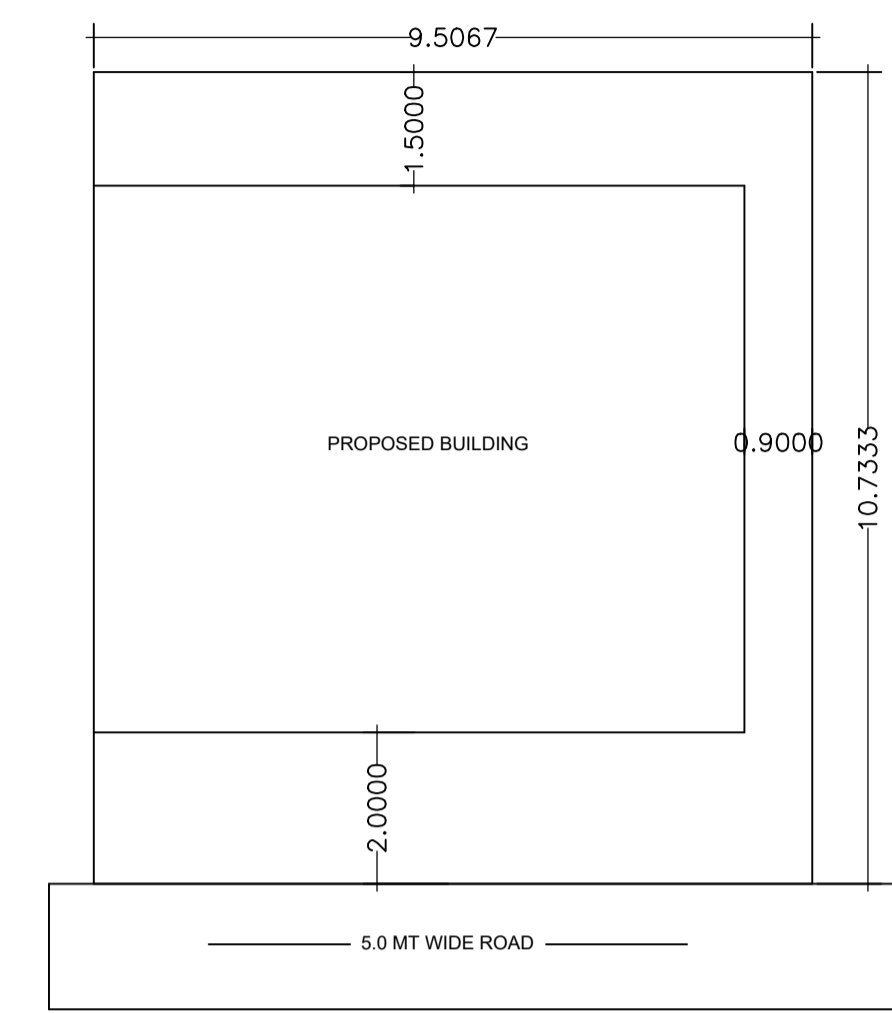
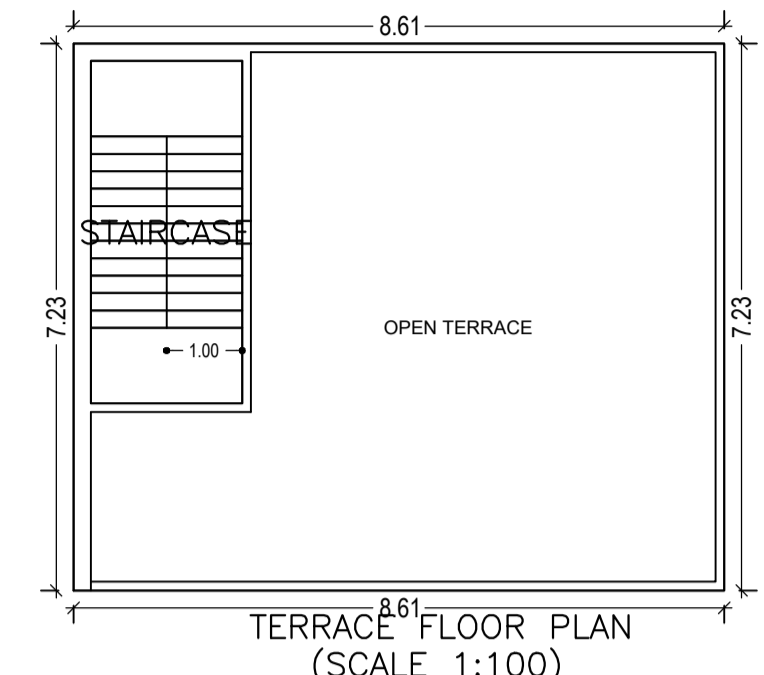
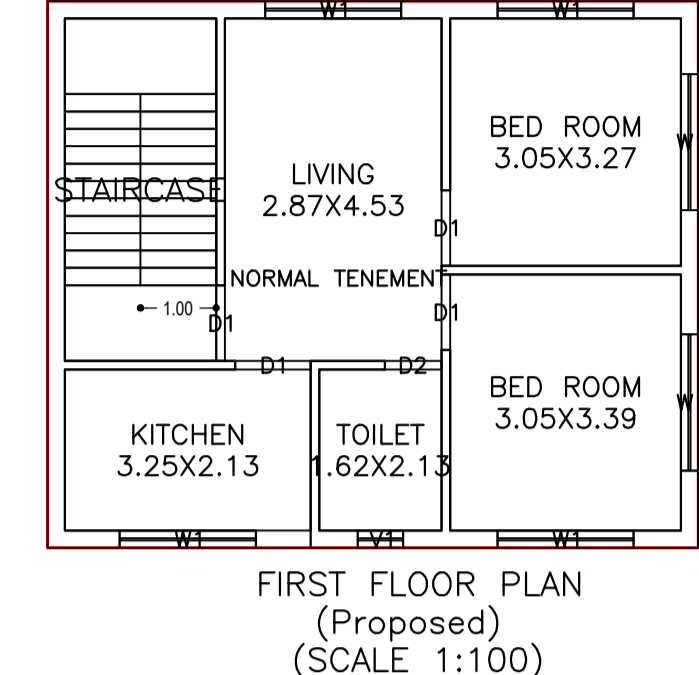
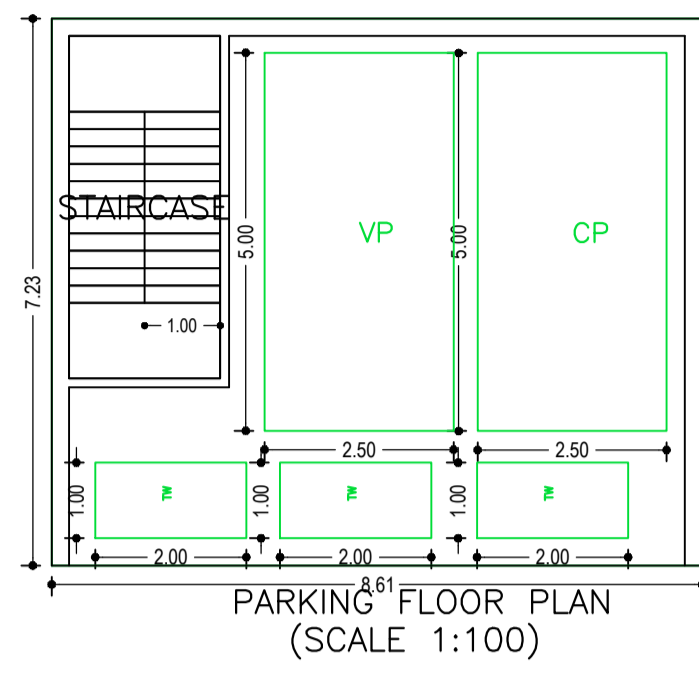

Buildingwise Floor FAR Details

Floor Name	Building Name		Total	
	Proposed Built Up Area (Sq.mt.)	Proposed FAR Area (Sq.mt.)	Total Proposed Built Up Area (Sq.mt.)	Total FAR Area (Sq.mt.)
Parking Floor	62.25	9.06	62.25	9.06
First Floor	62.25	62.25	62.25	62.25
Terrace Floor	0.00	0.00	0.00	0.00
Total :	124.50	71.31	124.50	71.31

FAR & Tenement Details (Table 4c-1)

Building	No. of Same Bldg	Total Built Up Area (Sq.mt.)	Deductions (Area in Sq.mt.)		Proposed FAR Area (Sq.mt.)	Add Area In FAR (Sq.mt.)	Total FAR Area (Sq.mt.)	Total Consumed Additional FAR Area (Sq.mt.)	Trmt (No.)
			Parking	Resi.					
A (BUILDING)	1	124.50	53.19	62.25	9.06	71.31	71.31	01	
Grand Total :	1	124.50	53.19	62.25	9.06	71.31	71.31	01	

Building :A (BUILDING)

Floor Name	Total Built Up Area (Sq.mt.)	Deductions (Area in Sq.mt.)		Proposed FAR Area (Sq.mt.)	Add Area In FAR (Sq.mt.)	Total FAR Area (Sq.mt.)	Total Consumed Additional FAR Area (Sq.mt.)	Trmt (No.)
		Parking	Resi.					
Parking Floor	62.25	53.19	0.00	9.06	0.00	9.06	9.06	00
First Floor	62.25	0.00	62.25	0.00	62.25	62.25	62.25	01
Terrace Floor	0.00	0.00	0.00	0.00	0.00	0.00	0.00	00
Total :	124.50	53.19	62.25	9.06	71.31	71.31	71.31	01

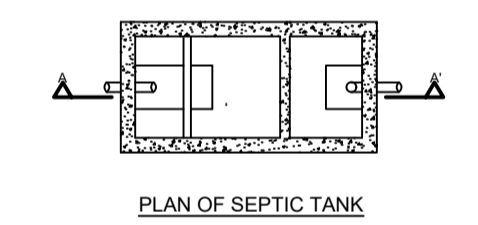
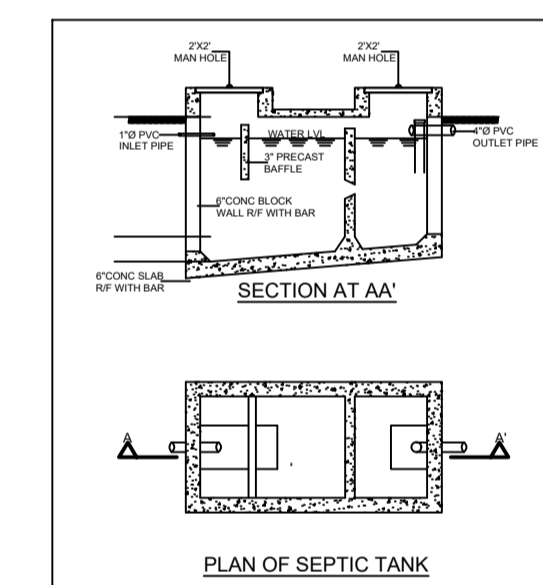
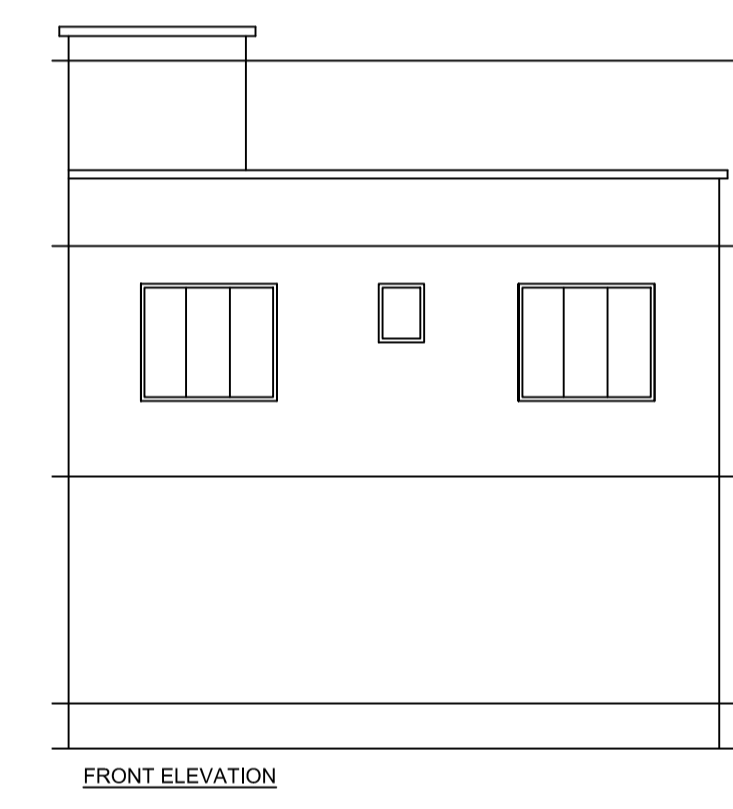
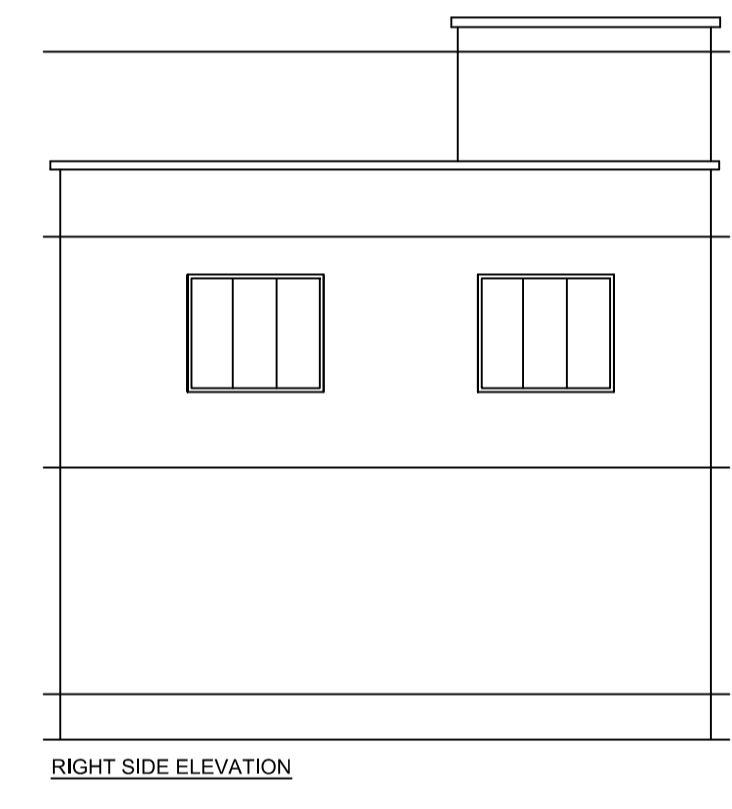
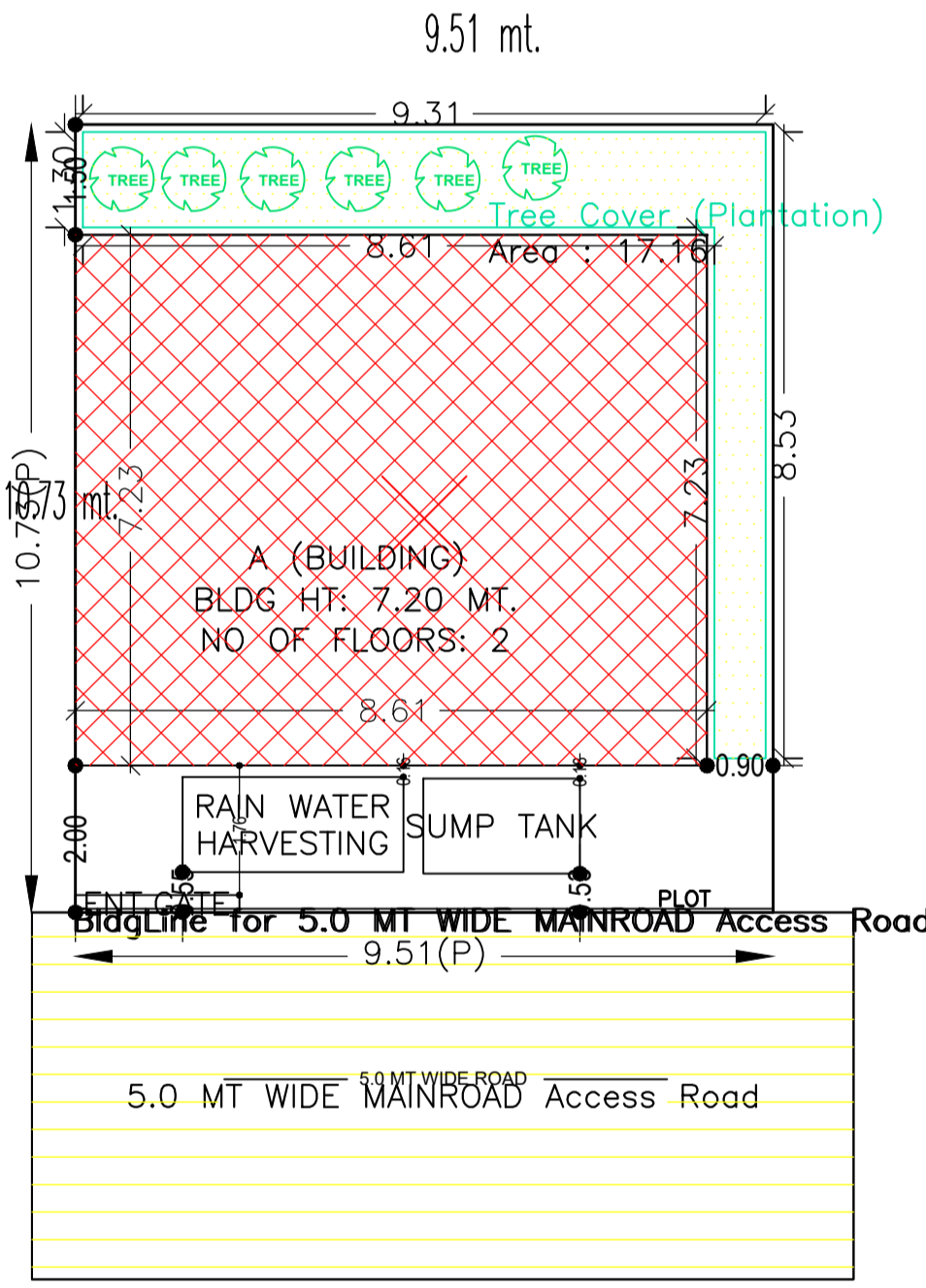

Building USE/SUBUSE Details

Building Name	Building Use	Building SubUse	Building Structure
A (BUILDING)	Residential	Bungalow/ Dwelling / Non Apartment	Non-Highrise

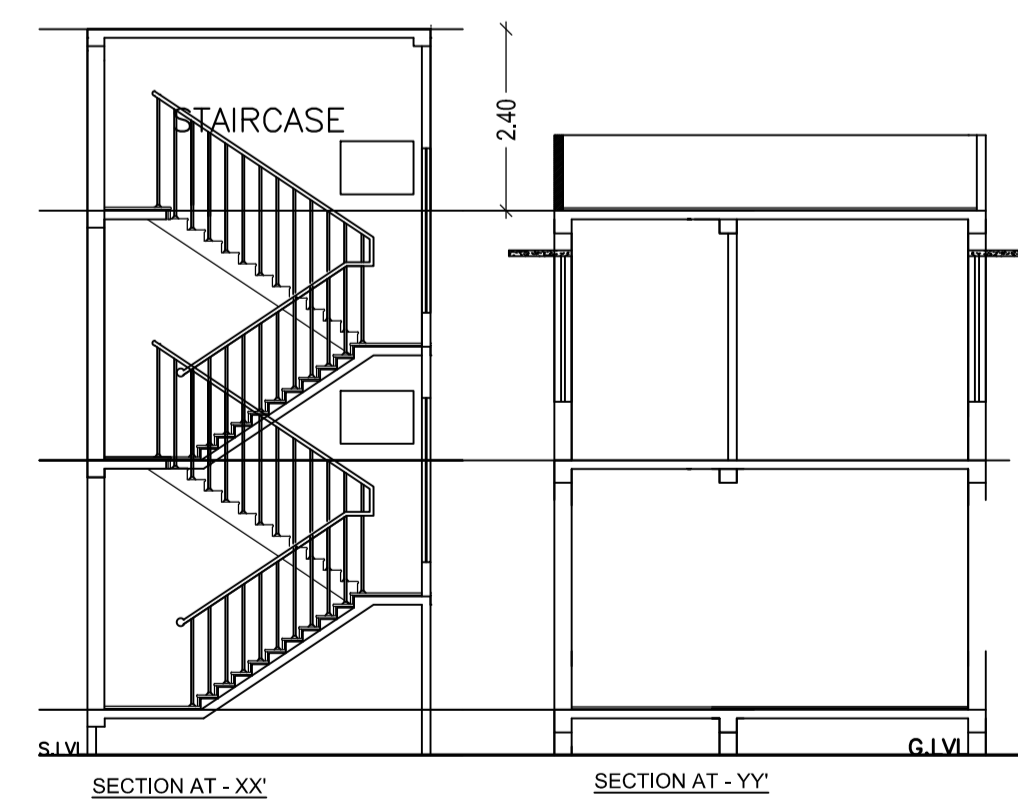
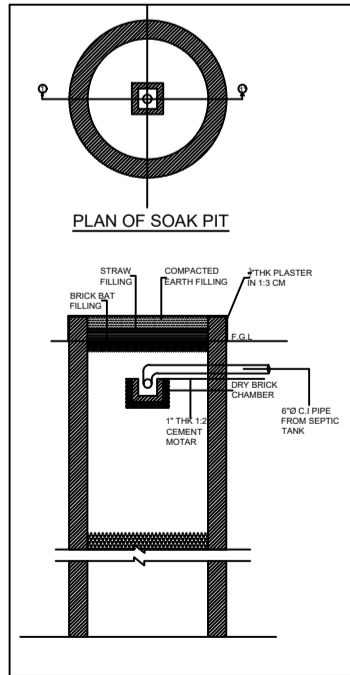
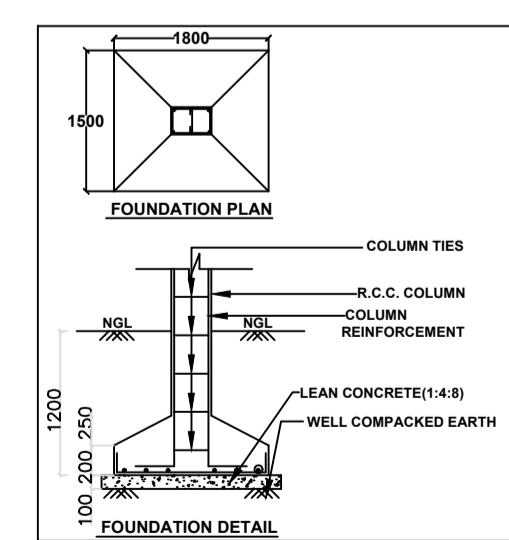
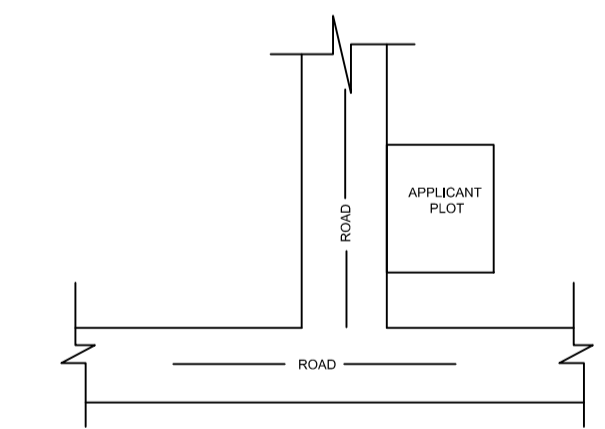
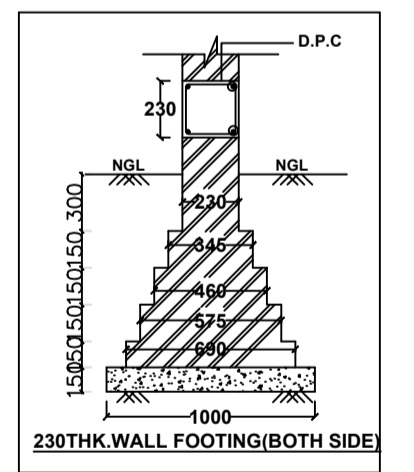
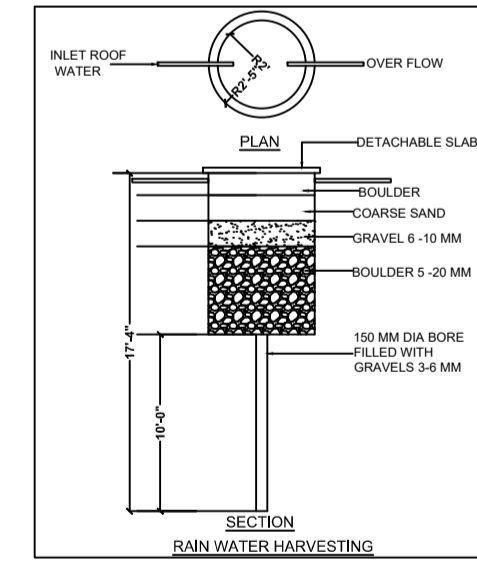

AREA STATEMENT GARHWA NAGAR PARISHAD		VERSION NO. : 1.0.30
		VERSION DATE: 30/06/2018
PROJECT DETAIL:		
Region: JHARKHAND URBAN LOCAL BODIES	Plot Use: Residential	
District: GARHWA	Plot SubUse: Bungalow/ Dwelling / Non Apartment	
Authority: GARHWA NAGAR PARISHAD	PlotNearbyReligiousStructure: NA	
Inward_No: GNPC/BP/0083/W08/2018	Plot/SubPlot No: 657	
Application Type: General Proposal	North: Plot No. - 657	
Project Type: Building Permission	South: Plot No. - 657	
Nature of Development: New	East: Road Width - 5	
Location of Development Area: Old Area	West: Plot No. - 657	
AREA DETAILS:		
AREA OF PLOT (Minimum)	(A)	102.04
NET AREA OF PLOT(Gross Plot Area - Deduction from Gross Plot area)	(A-Deductions)	102.04
Deduction for Balance Plot Area(from Gross Plot Area)		
Common Plot		17.16
Total		17.16
BALANCE AREA OF PLOT(Net Plot Area - Recreational/Amenity spsce)	(A-Deductions)	84.88
PLOT AREA FOR COVERAGE(Net Plot Area)	(A-Deductions)	102.04
Plot Area for FAR (Net Plot Area + RoadWidening Area)	(A-Deductions)	102.04
COVERAGE CHECK		
Permissible Coverage area (70.00 %)		71.43
Proposed Coverage Area (61.01 %)		62.25
Total Prop. Coverage Area (61.01 %)		62.25
Balance coverage area (9.00 %)		9.18
FAR CHECK		
Perm. FAR Area (1.80)		183.67
Total Perm. FAR area		183.67
Residential FAR		62.25
Proposed FAR Area		71.31
Total Proposed FAR Area		71.31
Consumed FAR (Factor)		0.70
Balance FAR Area		112.36
BUILT UP AREA CHECK		
Total Proposed BuiltUp Area		124.50
ARCHITECT (Regd)	PRADEEP KUNTAL KUNTAL	
ENGINEER (Regd)		
SUPERVISOR (Regd)		
OWNER (Regd)	SHRI RAM AND OM SHRI KRISHNAM	
DEVELOPMENT AUTHORITY		LOCAL BODY

LTP NAME AND SIGNATURE	STRUCTURAL ENG'S NAME AND SIGNATURE	BUILDER NAME AND SIGNATURE	DIGITAL SIGNATURE
PRADEEP KUNTAL KUNTAL GNPC/ARC/0007/2017			