

Proposal Basic Information	
Proposal File No.	GNPC/BP/0097/W20/2018
Owner Name	AKSHAIVAR PRAJAPATI
Khata No	27
Plot No	1360,1364
Village Name	Tandwa
Use	Residential
SubUse	Bungalow/ Dwelling / Non Apartment

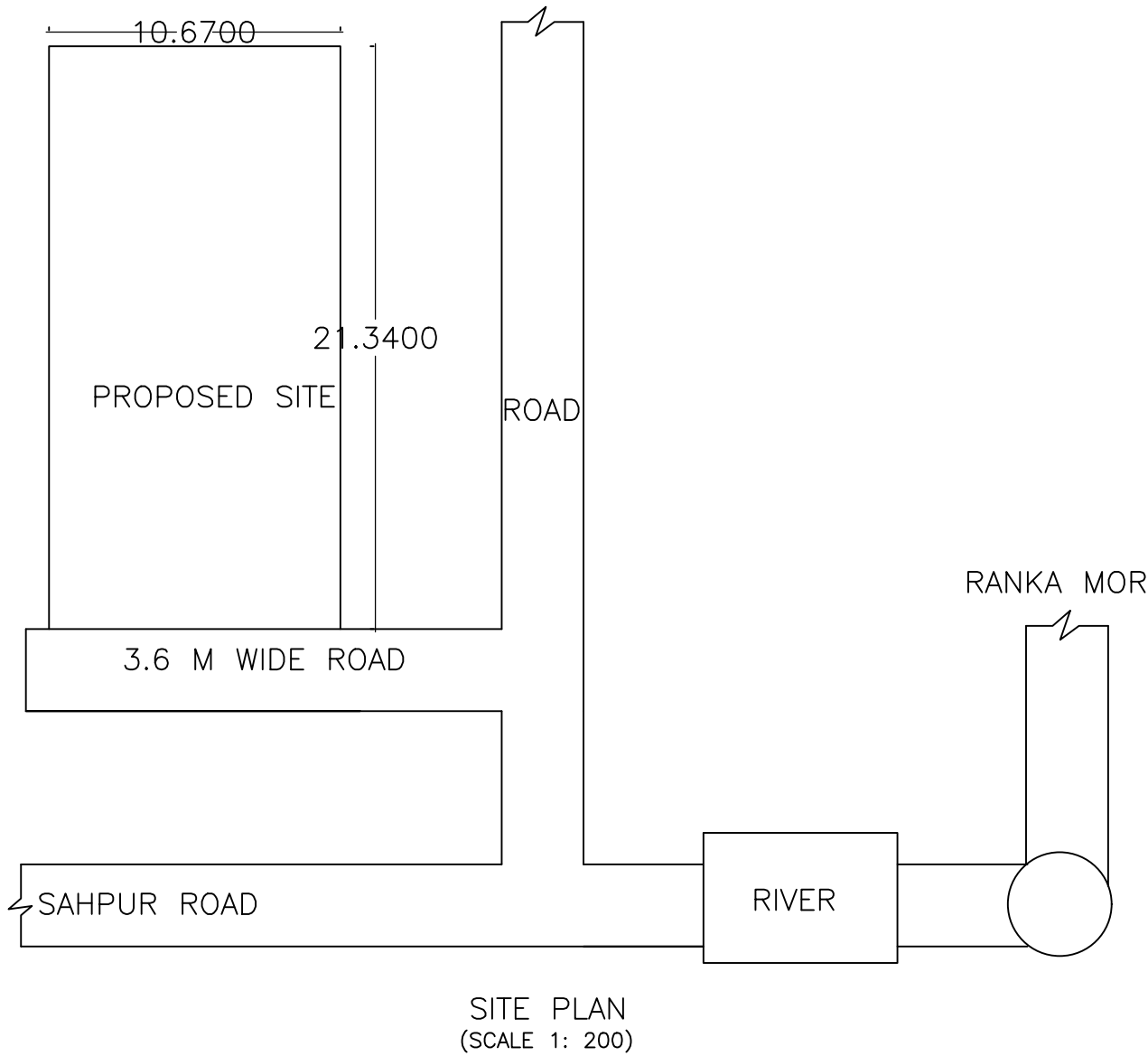
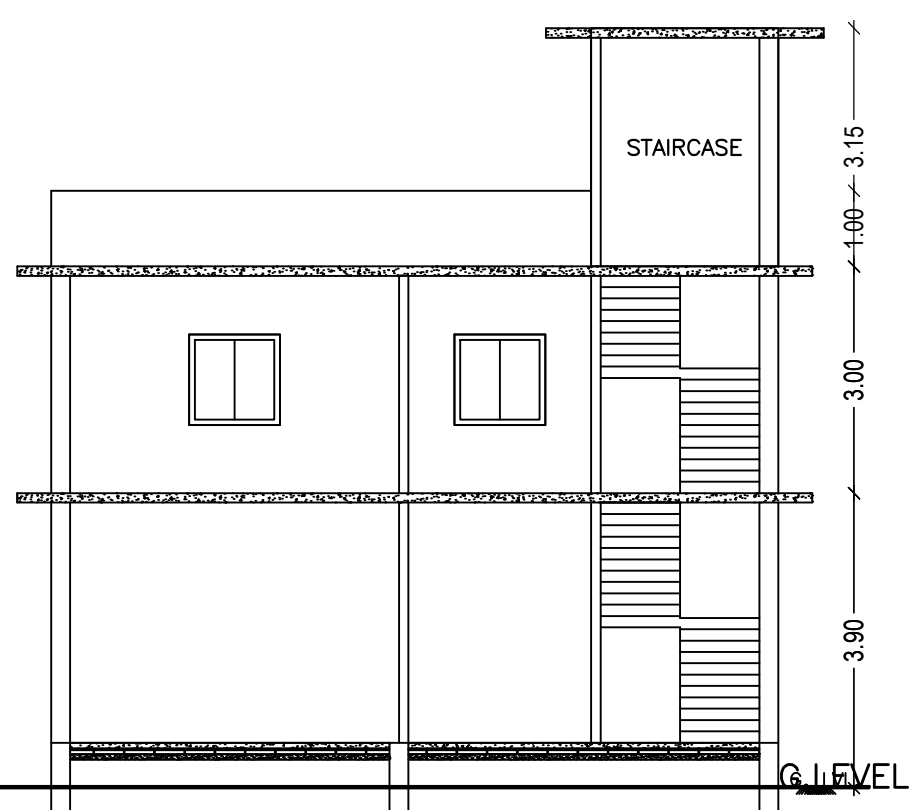
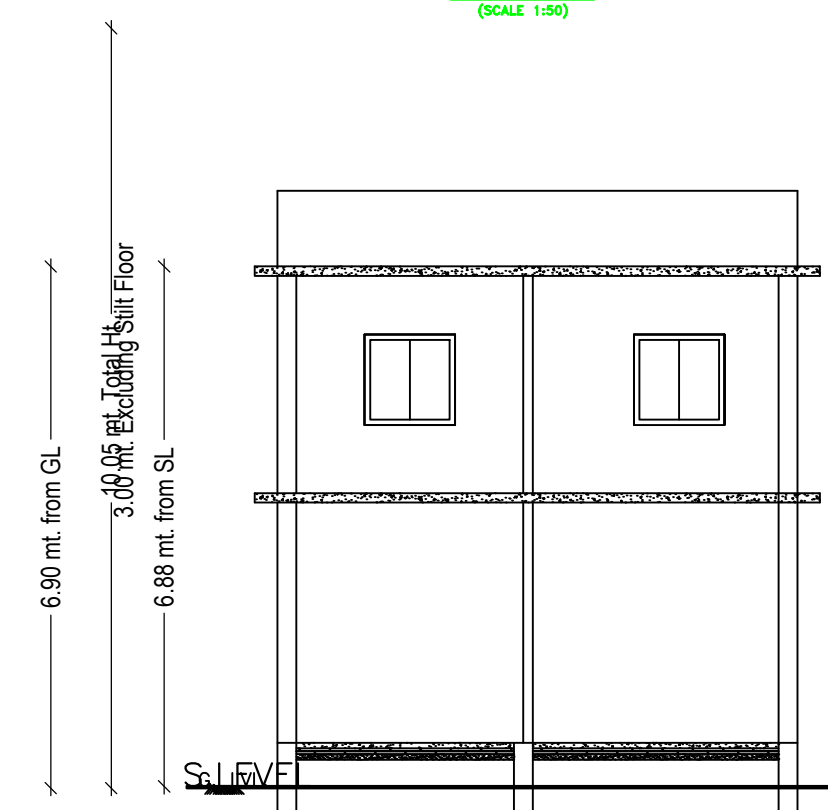
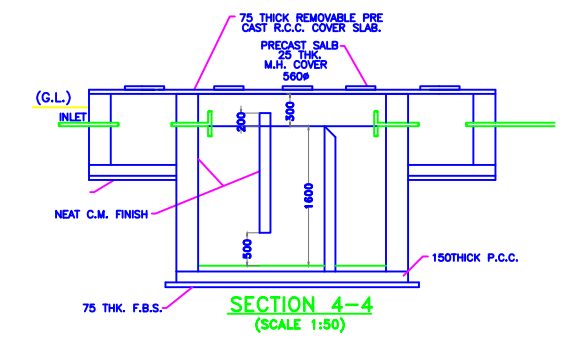
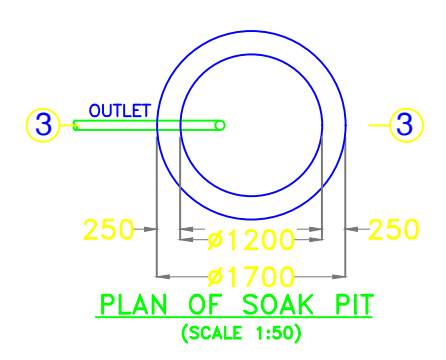
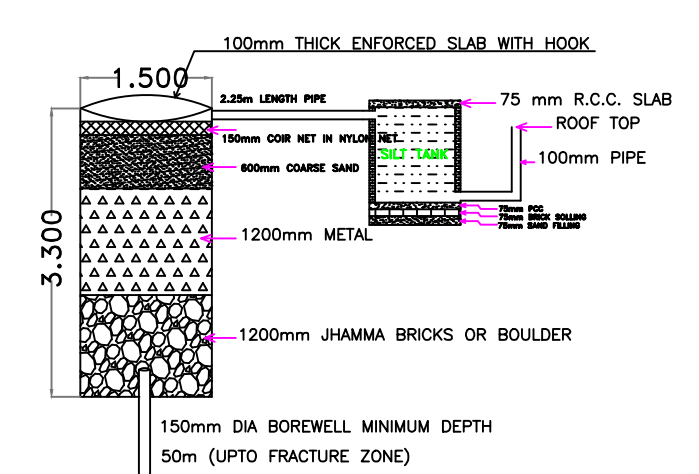
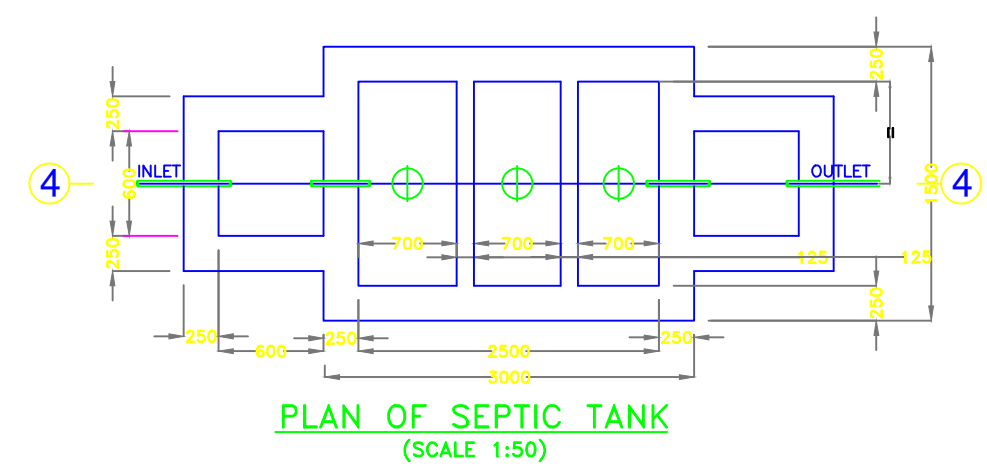

COLOR INDEX	
PLOT BOUNDARY	Black
ABUTTING ROAD	Green
PROPOSED CONSTRUCTION	Red
COMMON PLOT	Yellow
ROAD WIDENING AREA	Orange
EXISTING (To be retained)	Blue
EXISTING (To be demolished)	Light Blue

Building	No. of Same Bldg	Total Built Up Area (Sq.mt.)	Deductions (Area in Sq.mt.)	Proposed FAR Area (Sq.mt.)	Add Area in FAR (Sq.mt.)	Total FAR Area (Sq.mt.)	Total Consumed Additional FAR Area (Sq.mt.)	Tnmt (No.)
A (BUILDING)	1	113.36	49.54	56.68	7.14	63.82	63.82	01
Grand Total	1	113.36	49.54	56.68	7.14	63.82	63.82	01

Buildingwise Floor FAR Details

Floor Name	Building Name		Total	
	Proposed Built Up Area (Sq.mt.)	Proposed FAR Area (Sq.mt.)	Total Proposed Built Up Area (Sq.mt.)	Total FAR Area (Sq.mt.)
Parking Floor	56.68	7.14	56.68	7.14
First Floor	56.68	56.68	56.68	56.68
Terrace Floor	0.00	0.00	0.00	0.00
Total :	113.36	63.82	113.36	63.82

FAR & Tenement Details (Table 4c-1)

UnitBUA Table for Building :A (BUILDING)

FLOOR	Name	UnitBUA Type	UnitBUA Area	Carpet Area	No. of Rooms	No. of Tenement
FIRST FLOOR PLAN	NORMAL TENEMENT	FLAT	56.68	47.32	5	1
Total:	-	-	56.68	47.32	5	1

Building USE/SUBUSE Details

Building Name	Building Use	Building SubUse	Building Structure
A (BUILDING)	Residential	Bungalow/ Dwelling / Non Apartment	Non-Highrise

SCHEDULE OF DOOR:

BUILDING NAME	NAME	LENGTH	HEIGHT	NOS
A (BUILDING)	D3	0.75	2.10	01
A (BUILDING)	D2	0.90	2.10	01
A (BUILDING)	D1	1.05	2.10	02
A (BUILDING)	D1	1.15	2.10	01

SCHEDULE OF WINDOW/VENTILATION:

BUILDING NAME	NAME	LENGTH	HEIGHT	NOS
A (BUILDING)	V1	0.60	0.60	01
A (BUILDING)	W2	1.20	1.20	05
A (BUILDING)	W	1.80	1.50	01

Building :A (BUILDING)

Floor Name	Total Built Up Area (Sq.mt.)	Deductions (Area in Sq.mt.)	Proposed FAR Area (Sq.mt.)	Add Area in FAR (Sq.mt.)	Total FAR Area (Sq.mt.)	Total Consumed Additional FAR Area (Sq.mt.)	Tnmt (No.)
Parking Floor	56.68	49.54	0.00	7.14	7.14	0.00	00
First Floor	56.68	0.00	56.68	0.00	56.68	56.68	01
Terrace Floor	0.00	0.00	0.00	0.00	0.00	0.00	00
Total :	113.36	49.54	56.68	7.14	63.82	63.82	01

AREA STATEMENT GARHWA NAGAR PARISHAD		VERSION NO.: 1.0.30
PROJECT DETAIL:		VERSION DATE: 30/06/2018
Region: JHARKHAND URBAN LOCAL BODIES	Plot Use: Residential	
District: GARHWA	Plot SubUse: Bungalow/ Dwelling / Non Apartment	
Authority: GARHWA NAGAR PARISHAD	PlotNearbyReligiousStructure: NA	
Inward No: GNPC/BP/0097/W20/2018	Plot/SubPlot No: 1360,1364	
Application Type: General Proposal	North: Road Width - 3.6 M	
Project Type: Building Permission	South: Plot No. - 1360,1364	
Nature of Development: New	East: Plot No. - 1360,1364	
Location of Development Area: Old Area	West: Plot No. - 1360,1364	
AREA DETAILS: SQ.MT.		
AREA OF PLOT (Minimum)	(A)	227.70
NET AREA OF PLOT (Gross Plot Area - Deduction from Gross Plot area)	(A-Deductions)	227.70
Deduction for Balance Plot Area (from Gross Plot Area)		
Common Plot		27.55
Total		27.55
BALANCE AREA OF PLOT (Net Plot Area - Recreational/Amenity space)	(A-Deductions)	200.14
PLOT AREA FOR COVERAGE (Net Plot Area)	(A-Deductions)	227.70
Plot Area for FAR (Net Plot Area + Road Widening Area)	(A-Deductions)	227.70
COVERAGE CHECK		
Permissible Coverage area ( 70.00 % )		159.39
Proposed Coverage Area ( 24.89 % )		56.68
Total Prop. Coverage Area ( 24.89 % )		56.68
Balance coverage area ( 45.11 % )		102.71
FAR CHECK		
Perm. FAR Area ( 1.50 )		341.55
Total Perm. FAR area		341.55
Residential FAR		56.68
Proposed FAR Area		63.83
Total Proposed FAR Area		63.83
Consumed FAR (Factor)		0.28
Balance FAR Area		277.72
BUILT UP AREA CHECK		
Total Proposed BuiltUp Area		113.36
ARCHITECT (Regd) RESHAN ALI		
ENGINEER (Regd)		
SUPERVISOR (Regd)		
OWNER (Regd) AKSHAIVAR PRAJAPATI		
DEVELOPMENT AUTHORITY LOCAL BODY		

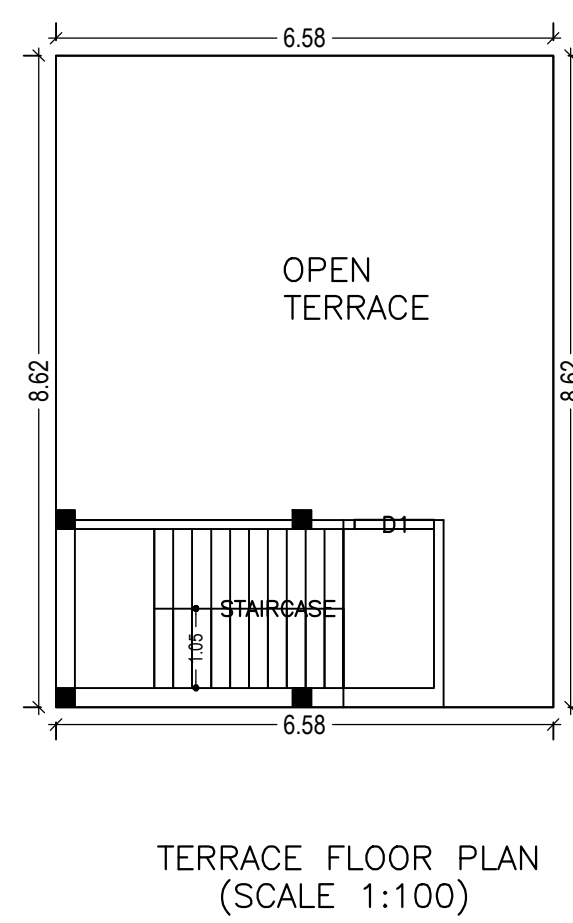
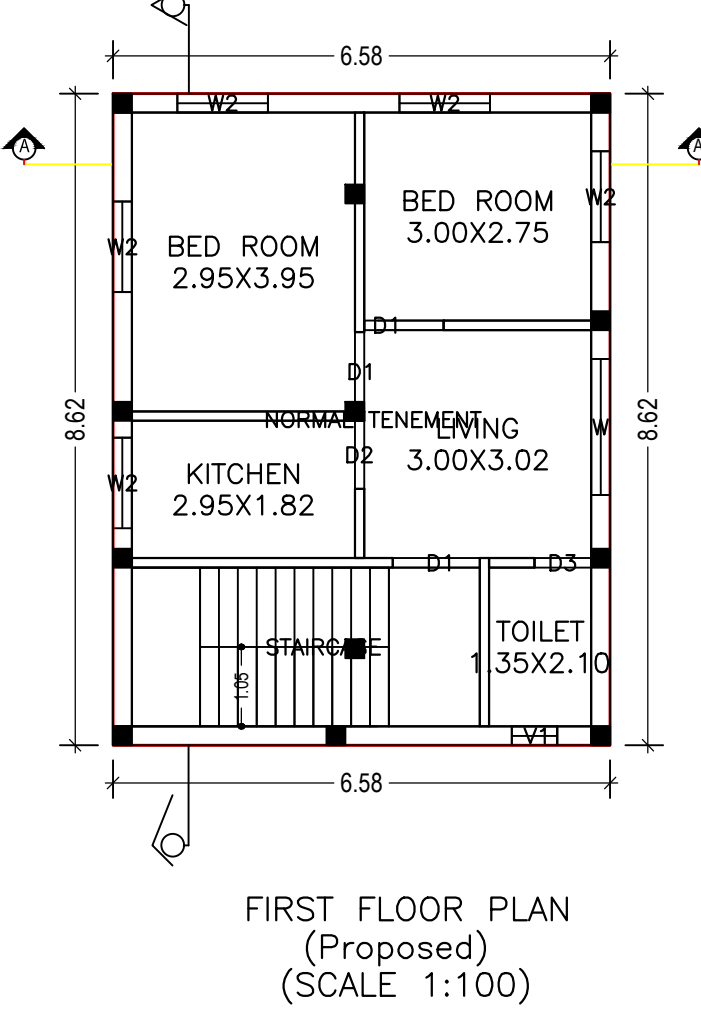
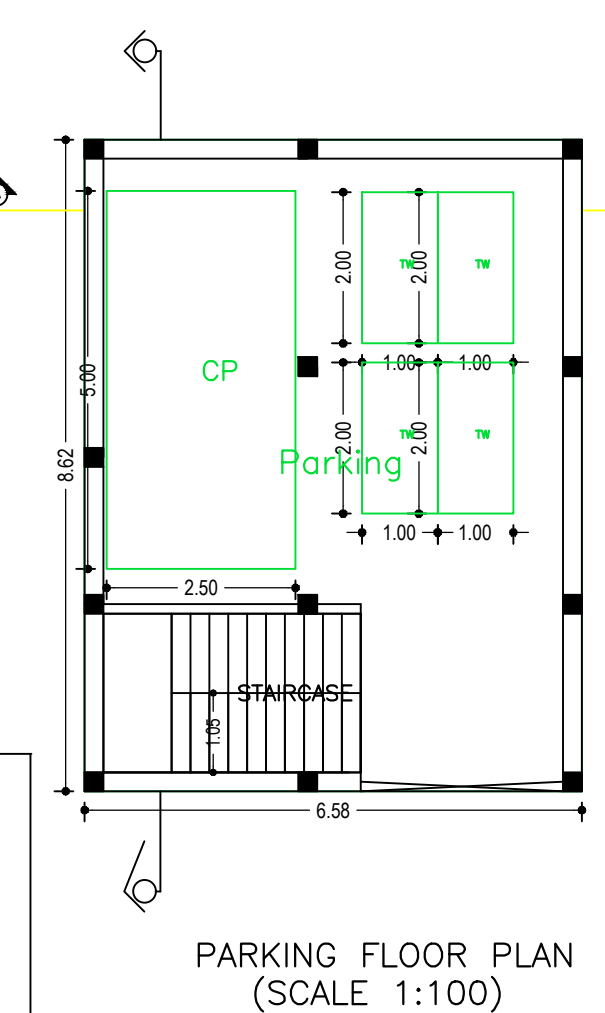
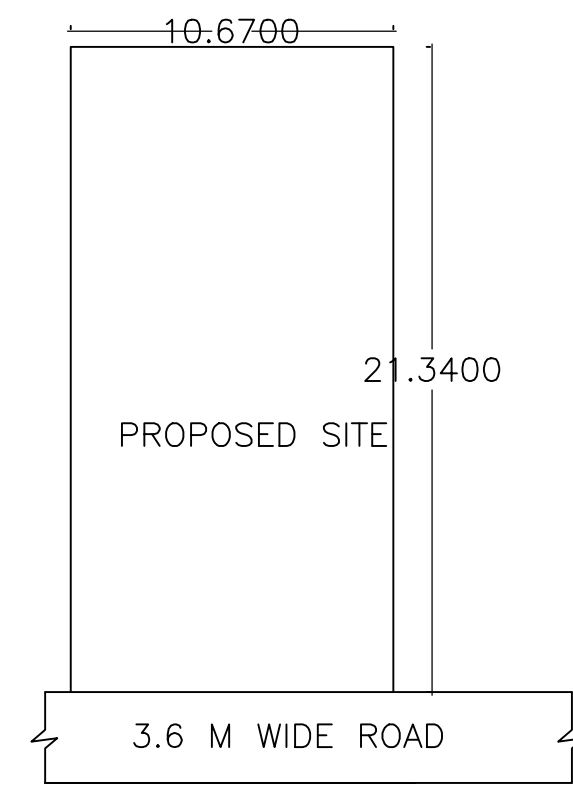
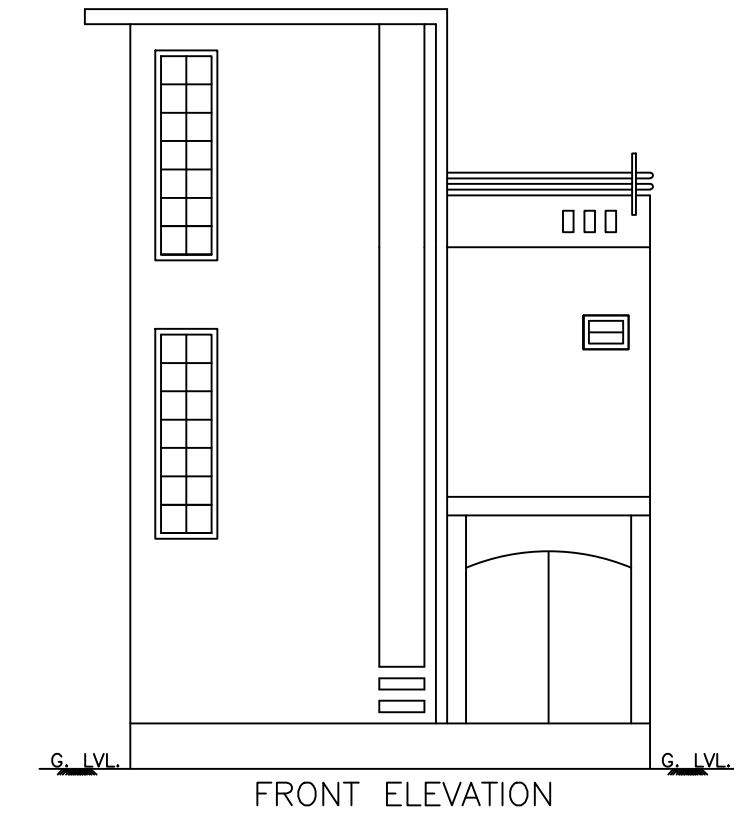
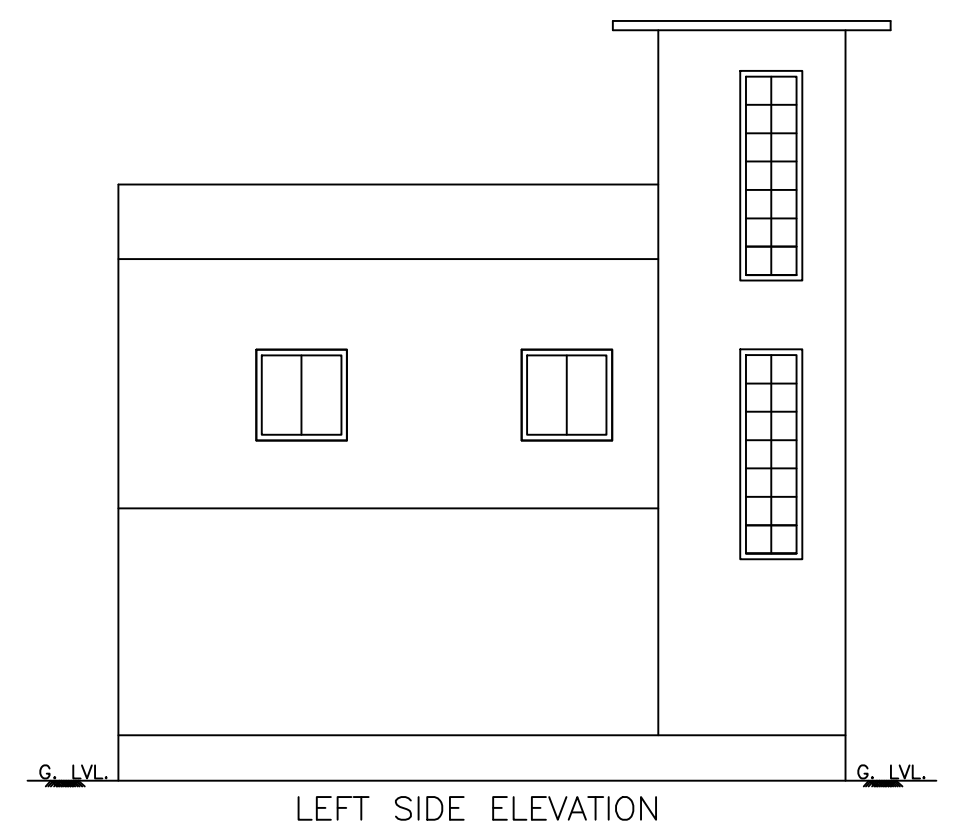
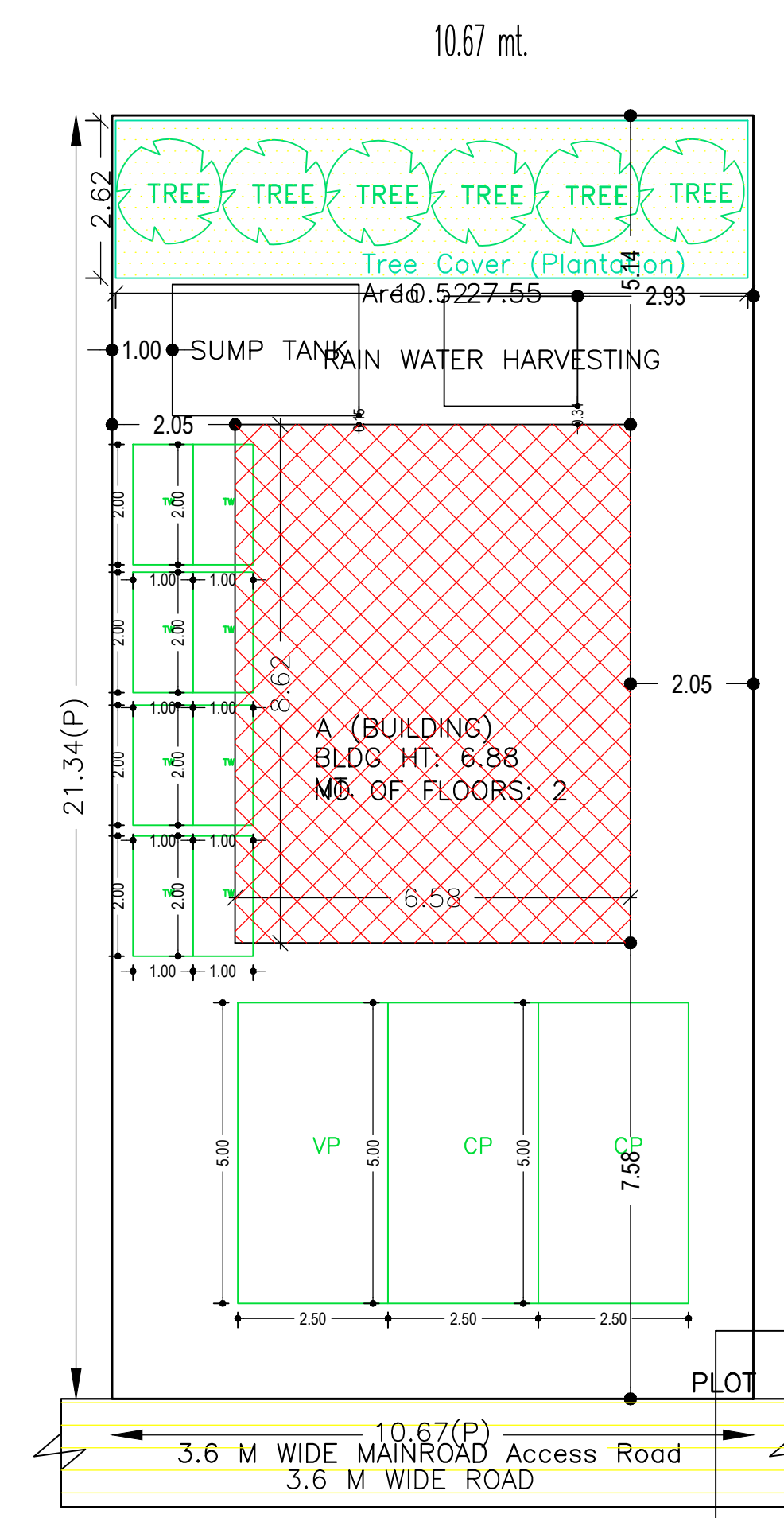

LTP NAME AND SIGNATURE	STRUCTURAL ENG'S NAME AND SIGNATURE	BUILDER NAME AND SIGNATURE	DIGITAL SIGNATURE
RESHAN ALI GNPC/ENG/0005/2017			