

Proposal Basic Information	
Proposal File No.	GNPC/BP/0056/W08/2019
Owner Name	JAY PRAKASH GUPTA
Khata No	33
Plot No	177
Village Name	Nagwa
Use	Residential
SubUse	Bungalow/ Dwelling / Non Apartment

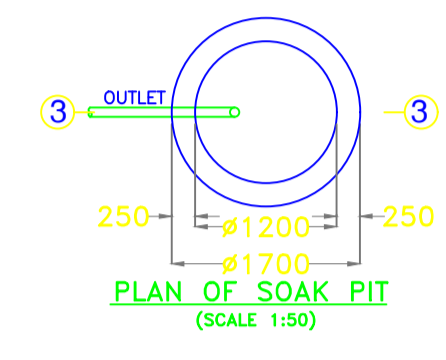
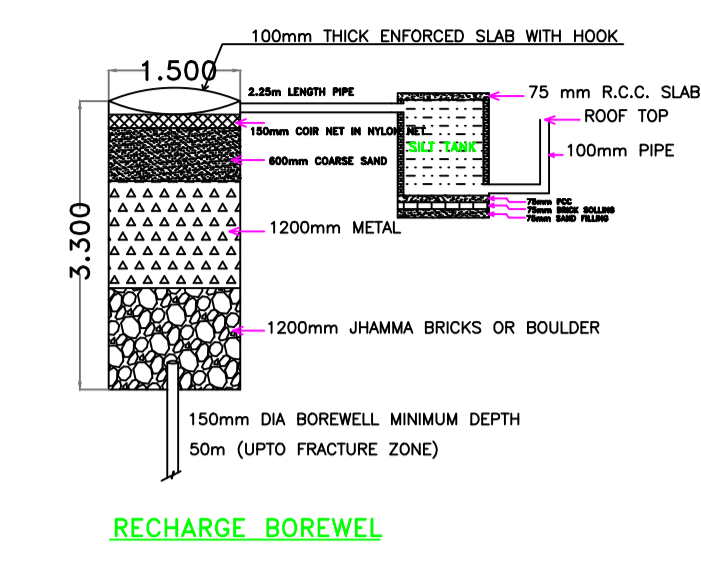
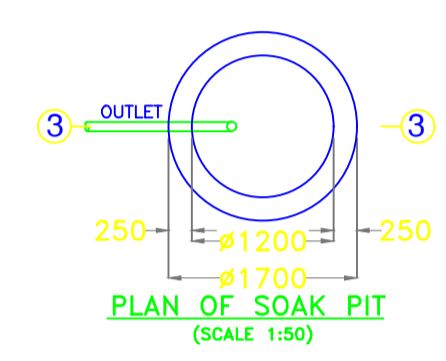
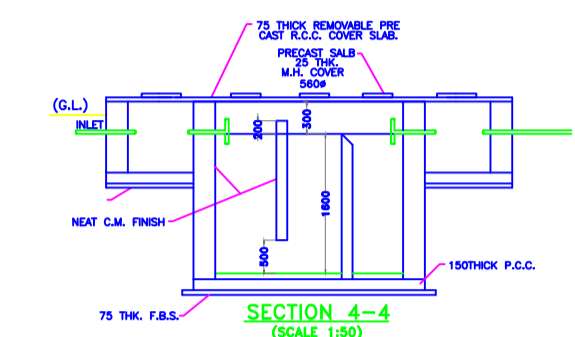
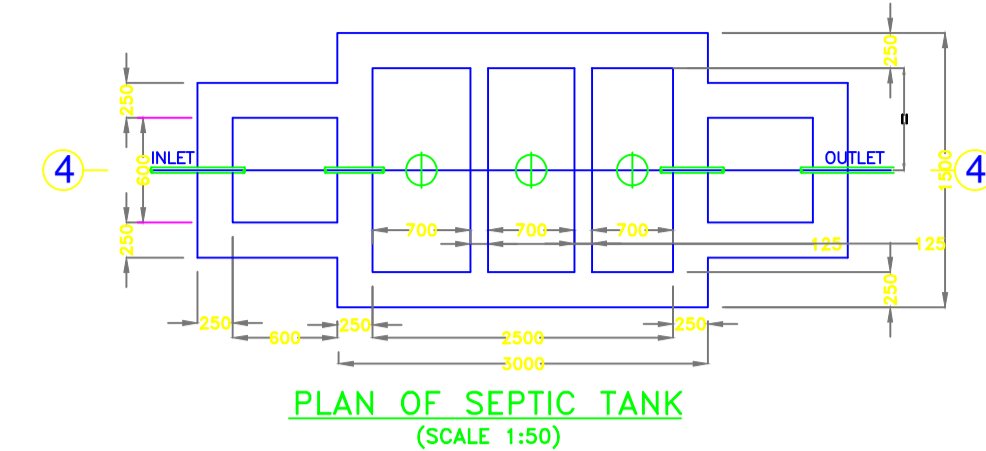
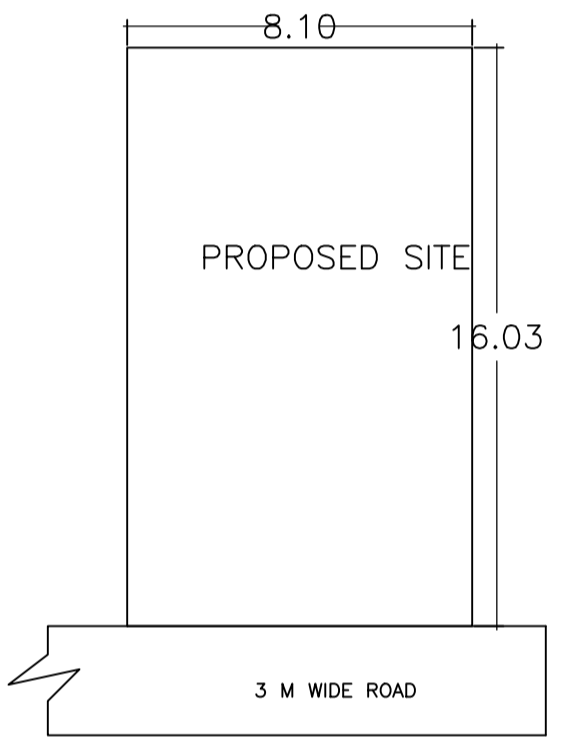
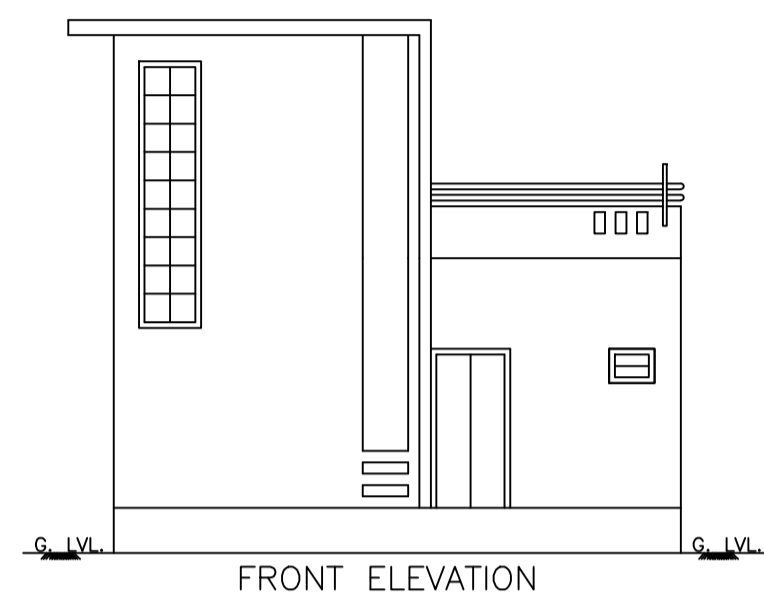
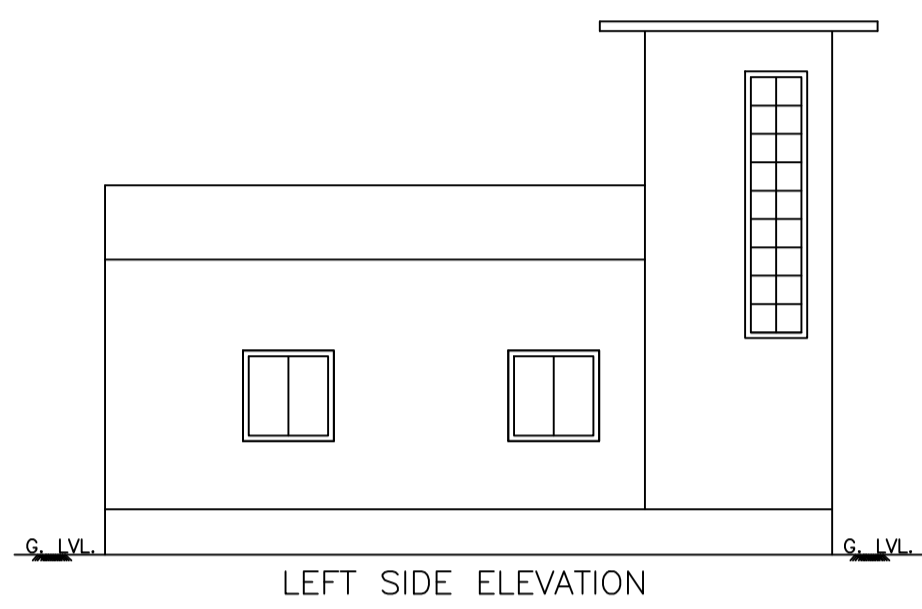
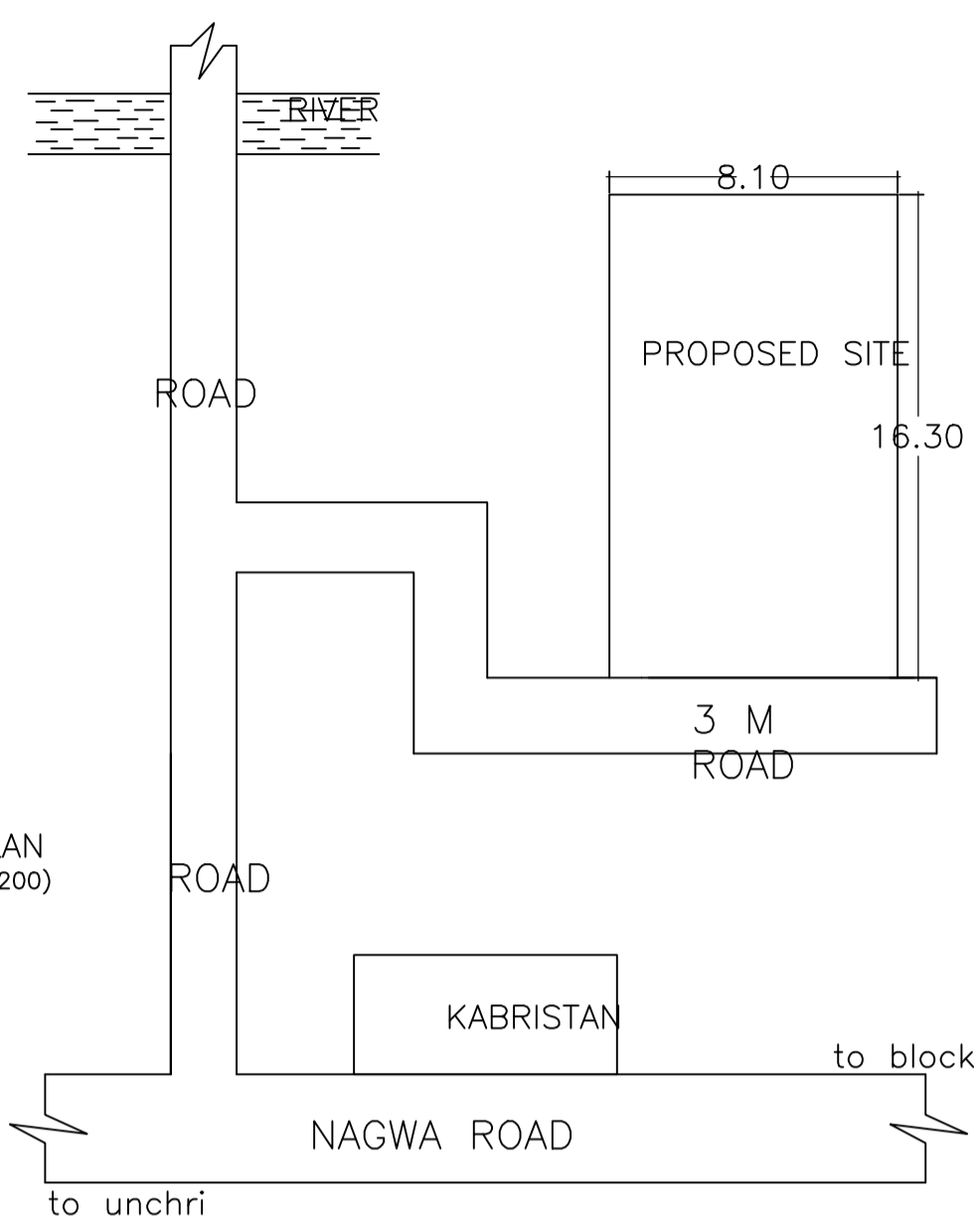

FAR & Tenement Details (Table 4c-1)

Building	No. of Same Bldg	Total Built Up Area (Sq.mt.)	Proposed FAR Area (Sq.mt.)	Total FAR Area (Sq.mt.)	Total Consumed Additional FAR Area (Sq.mt.)	Tnmt (No.)
A (BUILDING)	1	62.06	62.06	62.06	62.06	01
Grand Total :	1	62.06	62.06	62.06	62.06	01

Building USE/SUBUSE Details

Building Name	Building Use	Building SubUse	Building Structure
A (BUILDING)	Residential	Bungalow/ Dwelling / Non Apartment	Non-Highrise

Buildingwise Floor FAR Details

Floor Name	Building Name		Total	
	Proposed Built Up Area (Sq.mt.)	Proposed FAR Area (Sq.mt.)	Total Proposed Built Up Area (Sq.mt.)	Total FAR Area (Sq.mt.)
Ground Floor	62.06	62.06	62.06	62.06
Terrace Floor	0.00	0.00	0.00	0.00
Total :	62.06	62.06	62.06	62.06

COLOR INDEX	
PLOT BOUNDARY	Black
ABUTTING ROAD	Red
PROPOSED CONSTRUCTION	Green
COMMON PLOT	Yellow
ROAD WIDENING AREA	Orange
EXISTING (To be retained)	Blue
EXISTING (To be demolished)	Light Blue

AREA STATEMENT GARHWA		VERSION NO. 1.0.55
NAGAR PARISHAD		VERSION DATE: 16/10/2020
PROJECT DETAIL:		
Region: JHARKHAND URBAN LOCAL BODIES	Plot Use: Residential	
District: GARHWA	Plot SubUse: Bungalow/ Dwelling / Non Apartment	
Authority: GARHWA NAGAR PARISHAD	PlotNearbyReligiousStructure: NA	
Inward No: GNPC/BP/0056/W08/2019	Plot/SubPlot No: 177	
Application Type: General Proposal	North: Plot No. - 177	
Project Type: Building Permission	South: Plot No. - 177	
Nature of Development: New	East: Plot No. - 177	
Location of Development Area: Old Area	West: Road Width - 3	
AREA DETAILS:		
AREA OF PLOT (Minimum)	(A)	129.84
Deduction for NetPlot Area		
Surrender Free of Cost		2.43
Total		2.43
NET AREA OF PLOT(Gross Plot Area - Deduction from Gross Plot area)	(A-Deductions)	127.41
Deduction for Balance Plot Area(from Gross Plot Area)		
Surrender Free of Cost		2.43
Common Plot		15.73
Total		18.16
BALANCE AREA OF PLOT(Net Plot Area - Recreational/Amenity spaces)	(A-Deductions)	111.68
PLOT AREA FOR COVERAGE(Net Plot Area)	(A-Deductions)	127.41
Plot Area for FAR (Net Plot Area + RoadWidening Area)	(A-Deductions)	129.84
COVERAGE CHECK		
Permissible Coverage area (70.00 %)		89.19
Proposed Coverage Area (48.71 %)		62.06
Total Prop. Coverage Area (48.71 %)		62.06
Balance coverage area (21.29 %)		27.13
FAR CHECK		
Perm. FAR Area (1.20)		155.81
Total Perm. FAR area		155.81
Residential FAR		62.06
Proposed FAR Area		62.06
Total Proposed FAR Area		62.06
Consumed FAR (Factor)		0.48
Balance FAR Area		93.75
BUILT UP AREA CHECK		
Total Proposed BuiltUp Area		62.06
ARCHITECT (Regd)	RESHAN ALI	
ENGINEER (Regd)		
SUPERVISOR (Regd)		
OWNER (Regd)	JAY PRAKASH GUPTA	
DEVELOPMENT AUTHORITY		LOCAL BODY

UnitBUA Table for Building :A (BUILDING)

FLOOR	Name	UnitBUA Type	UnitBUA Area	Carpet Area	No. of Rooms	No. of Tenement
GROUND FLOOR	NORMAL TENEMENT	FLAT	62.06	52.64	5	1
Total	-	-	62.06	52.64	5	1

SCHEDULE OF DOOR:

BUILDING NAME	NAME	LENGTH	HEIGHT	NOS
A (BUILDING)	D3	0.75	2.10	01
A (BUILDING)	D2	0.90	2.10	01
A (BUILDING)	D1	1.05	2.10	03

SCHEDULE OF WINDOW/VENTILATION:

BUILDING NAME	NAME	LENGTH	HEIGHT	NOS
A (BUILDING)	V1	0.60	0.60	01
A (BUILDING)	W2	1.20	1.20	05
A (BUILDING)	W	1.80	1.50	01

Building :A (BUILDING)

Floor Name	Total Built Up Area (Sq.mt.)	Proposed FAR Area (Sq.mt.)	Total FAR Area (Sq.mt.)	Total Consumed Additional FAR Area (Sq.mt.)	Tnmt (No.)
Ground Floor	62.06	62.06	62.06	62.06	01
Terrace Floor	0.00	0.00	0.00	0.00	00
Total :	62.06	62.06	62.06	62.06	01
Total Number of Same Buildings	1				
Total :	62.06	62.06	62.06	62.06	01

