

Proposal Basic Information

Proposal File No.	GNPC/BP/0003/W13/2019
Owner Name	SHRI SARJU PRASAD GUPTA
Khata No	128
Plot No	340
Village Name	Garhwa Bazar
Use	Residential
SubUse	Bungalow/ Dwelling / Non Apartment

COLOR INDEX	
PLOT BOUNDARY	Black
ABUTTING ROAD	Green
PROPOSED CONSTRUCTION	Red
COMMON PLOT	Yellow
ROAD WIDENING AREA	Orange
EXISTING (To be retained)	Blue
EXISTING (To be demolished)	Light Blue

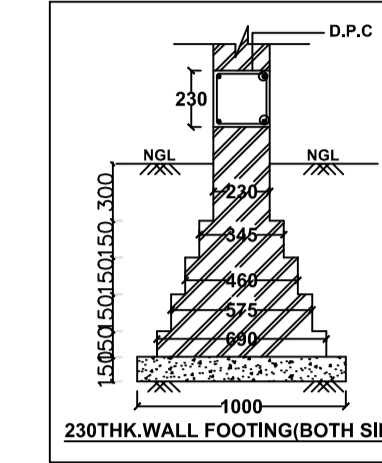
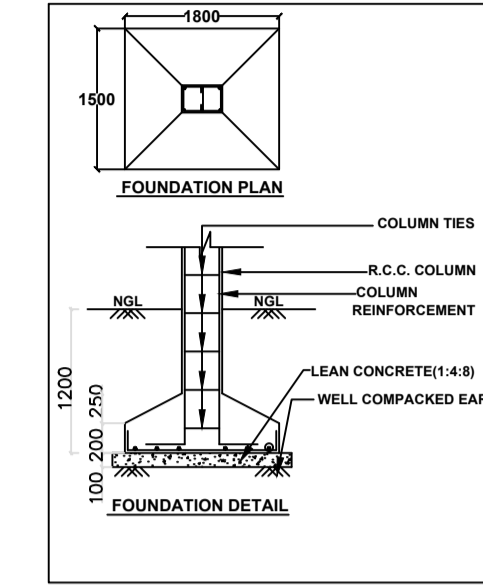
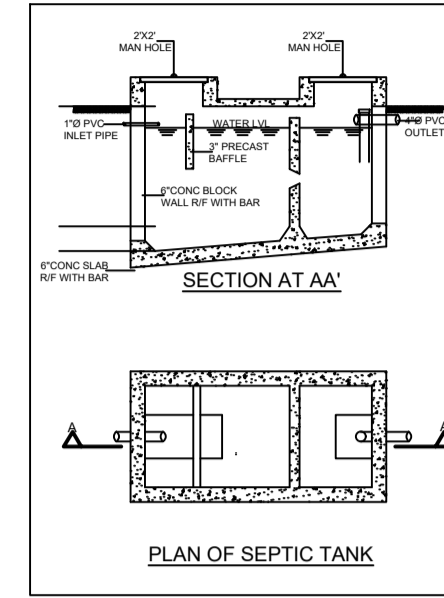
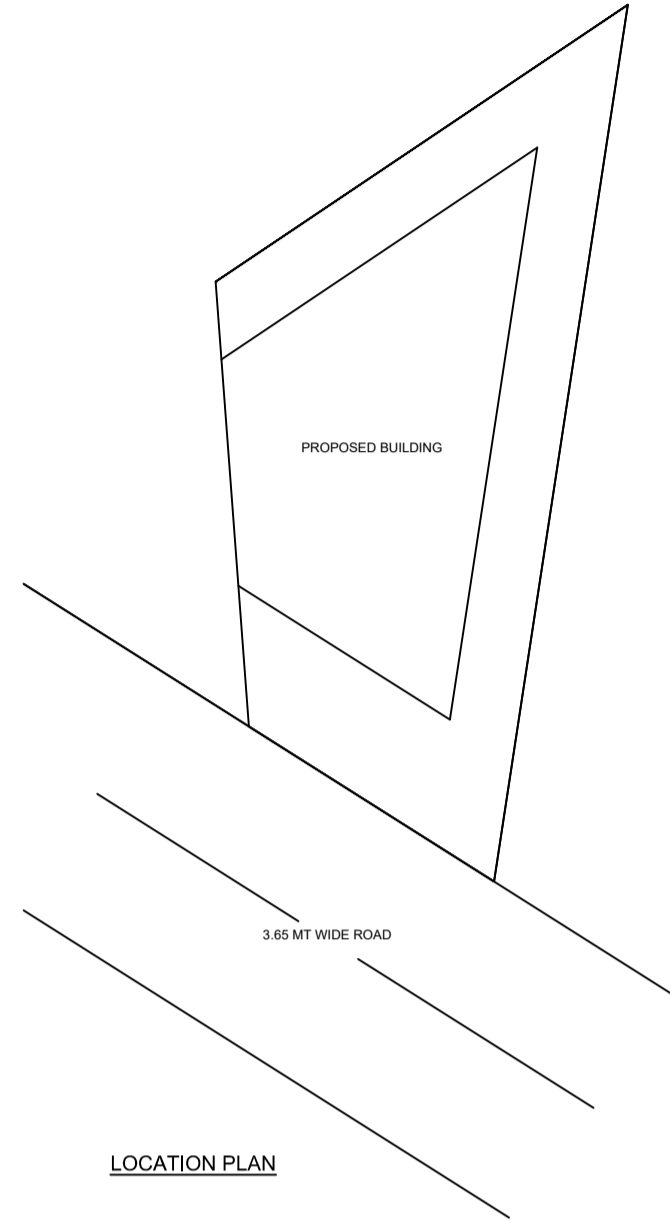
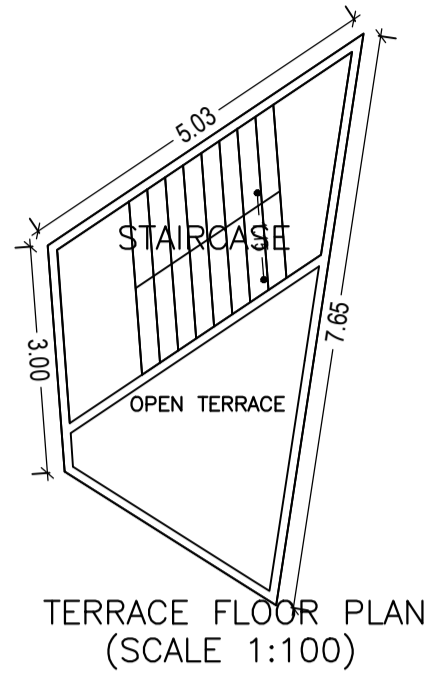
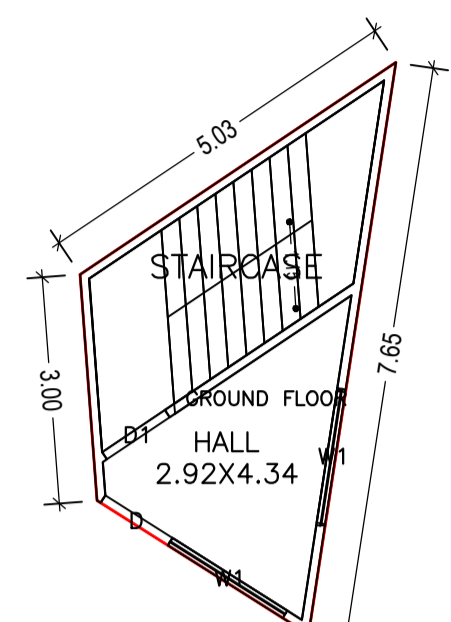

GROUND FLOOR PLAN (Proposed) (SCALE 1:100)

TERRACE FLOOR PLAN (SCALE 1:100)

LOCATION PLAN

PLAN OF SEPTIC TANK

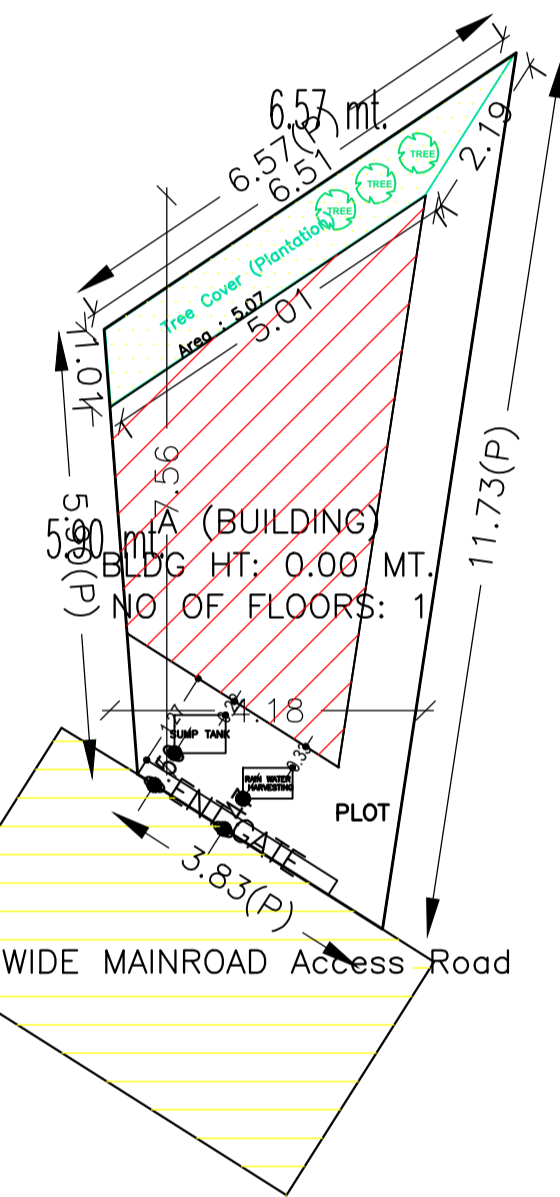
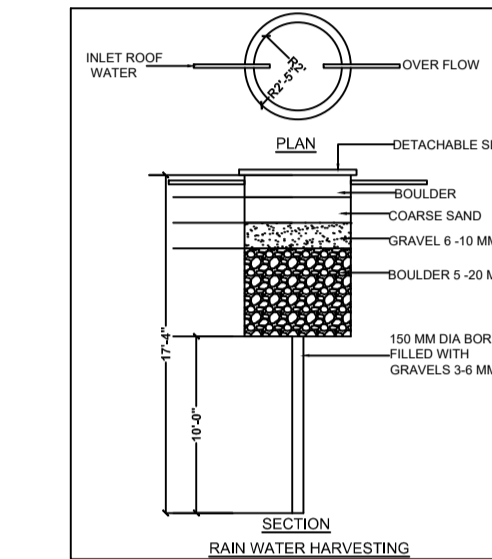
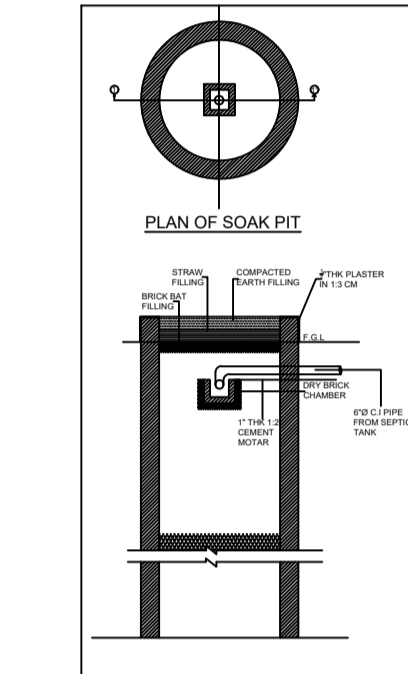

SITE PLAN

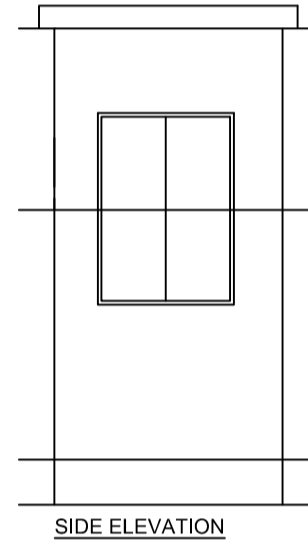

SIDE ELEVATION

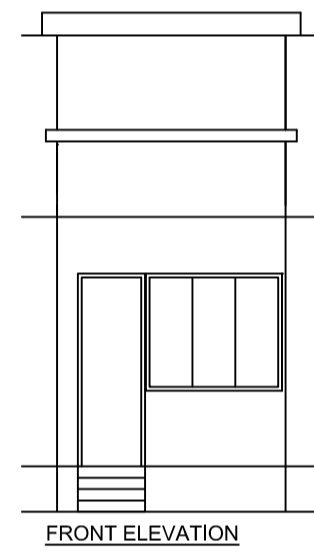

FRONT ELEVATION

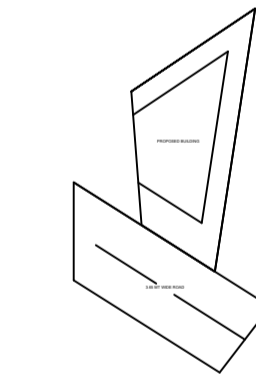

KEY PLAN

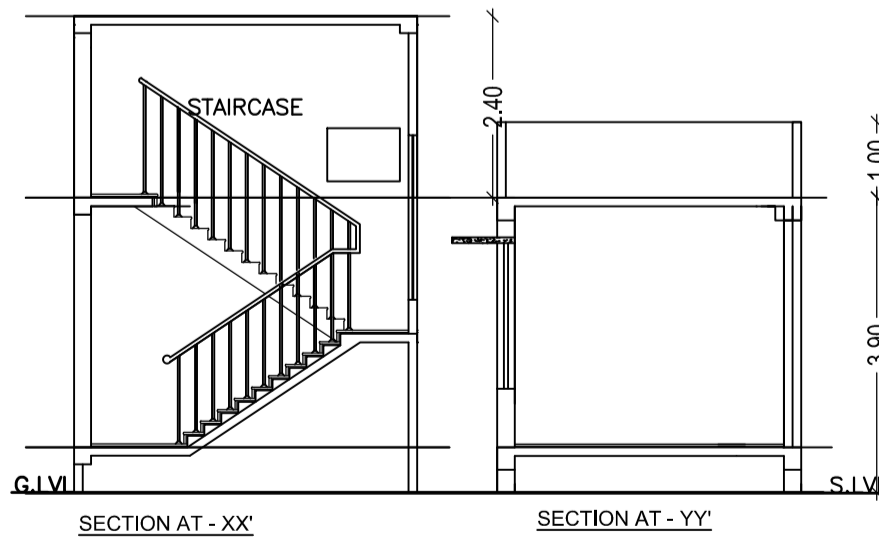

SECTION AT - XX'

SECTION AT - YY'

Buildingwise Floor FAR Details

Floor Name	Building Name A (BUILDING)		Total	
	Proposed Built Up Area (Sq.mt.)	Proposed FAR Area (Sq.mt.)	Total Proposed Built Up Area (Sq.mt.)	Total FAR Area (Sq.mt.)
Ground Floor	18.16	18.16	18.16	18.16
Terrace Floor	0.00	0.00	0.00	0.00
<b>Total :</b>	<b>18.16</b>	<b>18.16</b>	<b>18.16</b>	<b>18.16</b>

Building :A (BUILDING)

Floor Name	Total Built Up Area (Sq.mt.)	Proposed FAR Area (Sq.mt.) Resi.	Total FAR Area (Sq.mt.)	Total Consumed Additional FAR Area (Sq.mt.)	Tnmt (No.)
Ground Floor	18.16	18.16	18.16	18.16	01
Terrace Floor	0.00	0.00	0.00	0.00	00
<b>Total :</b>	<b>18.16</b>	<b>18.16</b>	<b>18.16</b>	<b>18.16</b>	<b>01</b>
Total Number of Same Buildings :	1				
<b>Total :</b>	<b>18.16</b>	<b>18.16</b>	<b>18.16</b>	<b>18.16</b>	<b>01</b>

Building USE/SUBUSE Details

Building Name	Building Use	Building SubUse	Building Structure
A (BUILDING)	Residential	Bungalow/ Dwelling / Non Apartment	Non-Highrise

FAR & Tenement Details (Table 4c-1)

Building	No. of Same Bldg	Total Built Up Area (Sq.mt.)	Proposed FAR Area (Sq.mt.) Resi.	Total FAR Area (Sq.mt.)	Total Consumed Additional FAR Area (Sq.mt.)	Tnmt (No.)
A (BUILDING)	1	18.16	18.16	18.16	18.16	01
<b>Grand Total :</b>	<b>1</b>	<b>18.16</b>	<b>18.16</b>	<b>18.16</b>	<b>18.16</b>	<b>01</b>

SCHEDULE OF DOOR:

BUILDING NAME	NAME	LENGTH	HEIGHT	NOS
A (BUILDING)	D1	1.00	2.10	01
A (BUILDING)	D	1.05	2.10	01

SCHEDULE OF WINDOW/VENTILATION:

BUILDING NAME	NAME	LENGTH	HEIGHT	NOS
A (BUILDING)	W1	1.80	1.20	02

UnitBUA Table for Building :A (BUILDING)

FLOOR	Name	UnitBUA Type	UnitBUA Area	Carpet Area	No. of Rooms	No. of Tenement
GROUND FLOOR PLAN	GROUND FLOOR	FLAT	18.16	15.82	1	1
<b>Total:</b>	-	-	<b>18.16</b>	<b>15.82</b>	<b>1</b>	<b>1</b>

AREA STATEMENT GARHWA NAGAR PARISHAD		VERSION NO.: 1.0.31
PROJECT DETAIL:		VERSION DATE: 30/06/2018
Region: JHARKHAND URBAN LOCAL BODIES	Plot Use: Residential	
District: GARHWA	Plot SubUse: Bungalow/ Dwelling / Non Apartment	
Authority: GARHWA NAGAR PARISHAD	PlotNearbyReligiousStructure: NA	
Inward No: GNPC/BP/0003/W13/2019	PlotSubPlot No: 340	
Application Type: General Proposal	North: Road Width - 3.65	
Project Type: Building Permission	South: Plot No. - 340	
Nature of Development: New	East: Plot No. - 340	
Location of Development Area: Old Area	West: Plot No. - 340	
AREA DETAILS:		
AREA OF PLOT (Minimum)	(A)	SQ.MT. 37.46
NET AREA OF PLOT(Gross Plot Area - Deduction from Gross Plot area)	(A-Deductions)	37.46
Deduction for Balance Plot Area(from Gross Plot Area)		
Common Plot		5.07
Total		5.07
BALANCE AREA OF PLOT(Net Plot Area - Recreational/Amenity space)	(A-Deductions)	32.39
PLOT AREA FOR COVERAGE(Net Plot Area)	(A-Deductions)	
Plot Area for FAR (Net Plot Area + Road/Widening Area)	(A-Deductions)	37.46
COVERAGE CHECK		
Permissible Coverage area ( 70.00 % )		26.22
Proposed Coverage Area ( 48.48 % )		18.16
Total Prop. Coverage Area ( 48.48 % )		18.16
Balance coverage area ( 21.52 % )		8.06
FAR CHECK		
Perm. FAR Area ( 1.50 )		58.19
Total Perm. FAR area		58.19
Residential FAR		18.16
Proposed FAR Area		18.16
Total Proposed FAR Area		18.16
Consumed FAR (Factor)		0.48
Balance FAR Area		38.03
BUILT UP AREA CHECK		
Total Proposed BuiltUp Area		18.16
ARCHITECT (Regd)	PRADEEP KUNTAL KUNTAL	
ENGINEER (Regd)		
SUPERVISOR (Regd)		
OWNER (Regd)	SHRI SARJU PRASAD GUPTA	
DEVELOPMENT AUTHORITY		LOCAL BODY

LTP NAME AND SIGNATURE	STRUCTURAL ENG'S NAME AND SIGNATURE	BUILDER NAME AND SIGNATURE	DIGITAL SIGNATURE
PRADEEP KUNTAL KUNTAL GNPC/ARC/0007/2017			