

Proposal Basic Information

Proposal File No.	GNPC/BP/0002/W07/2019
Owner Name	SMT UMA DEVI
Khata No	52
Plot No	191
Village Name	Pipra Kala
Use	Residential
SubUse	Bungalow/ Dwelling / Non Apartment

COLOR INDEX

PLOT BOUNDARY	Black
ABUTTING ROAD	Green
PROPOSED CONSTRUCTION	Red
COMMON PLOT	Yellow
ROAD WIDENING AREA	Orange
EXISTING (To be retained)	Blue
EXISTING (To be demolished)	Light Blue

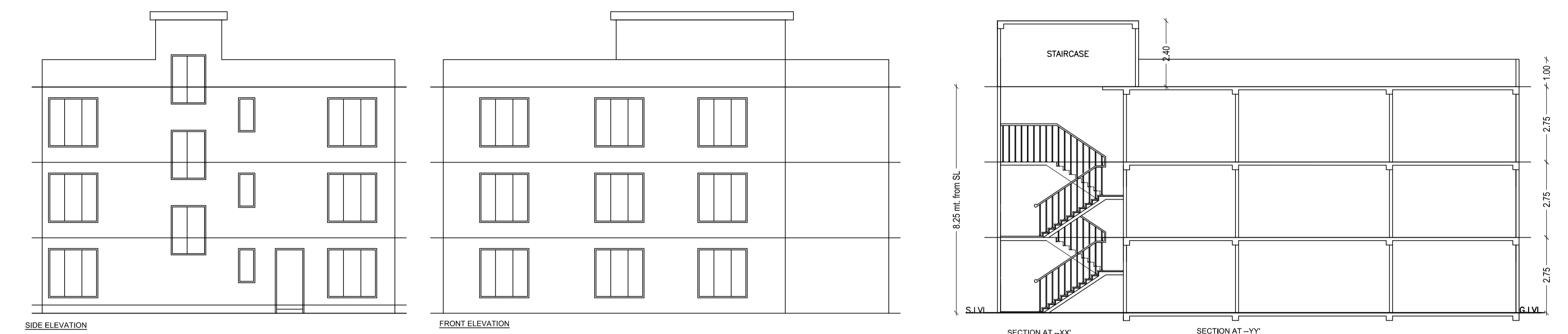

FAR & Tenement Details (Table 4c-1)

Building	No. of Same Bldg	Total Built Up Area (Sq.mt.)	Proposed FAR Area (Sq.mt.)	Total FAR Area (Sq.mt.)	Total Consumed Additional FAR Area (Sq.mt.)	Tnmt (No.)
A (BUILDING)	1	536.07	536.07	536.07	536.07	03
Grand Total :	1	536.07	536.07	536.07	536.07	03

Building USE/SUBUSE Details

Building Name	Building Use	Building SubUse	Building Structure
A (BUILDING)	Residential	Bungalow/ Dwelling / Non Apartment	Non-Highrise

Buildingwise Floor FAR Details

Floor Name	Building Name A (BUILDING)		Total	
	Proposed Built Up Area (Sq.mt.)	Proposed FAR Area (Sq.mt.)	Total Proposed Built Up Area (Sq.mt.)	Total FAR Area (Sq.mt.)
Ground Floor	178.69	178.69	178.69	178.69
First Floor	178.69	178.69	178.69	178.69
Second Floor	178.69	178.69	178.69	178.69
Terrace Floor	0.00	0.00	0.00	0.00
Total :	536.07	536.07	536.07	536.07

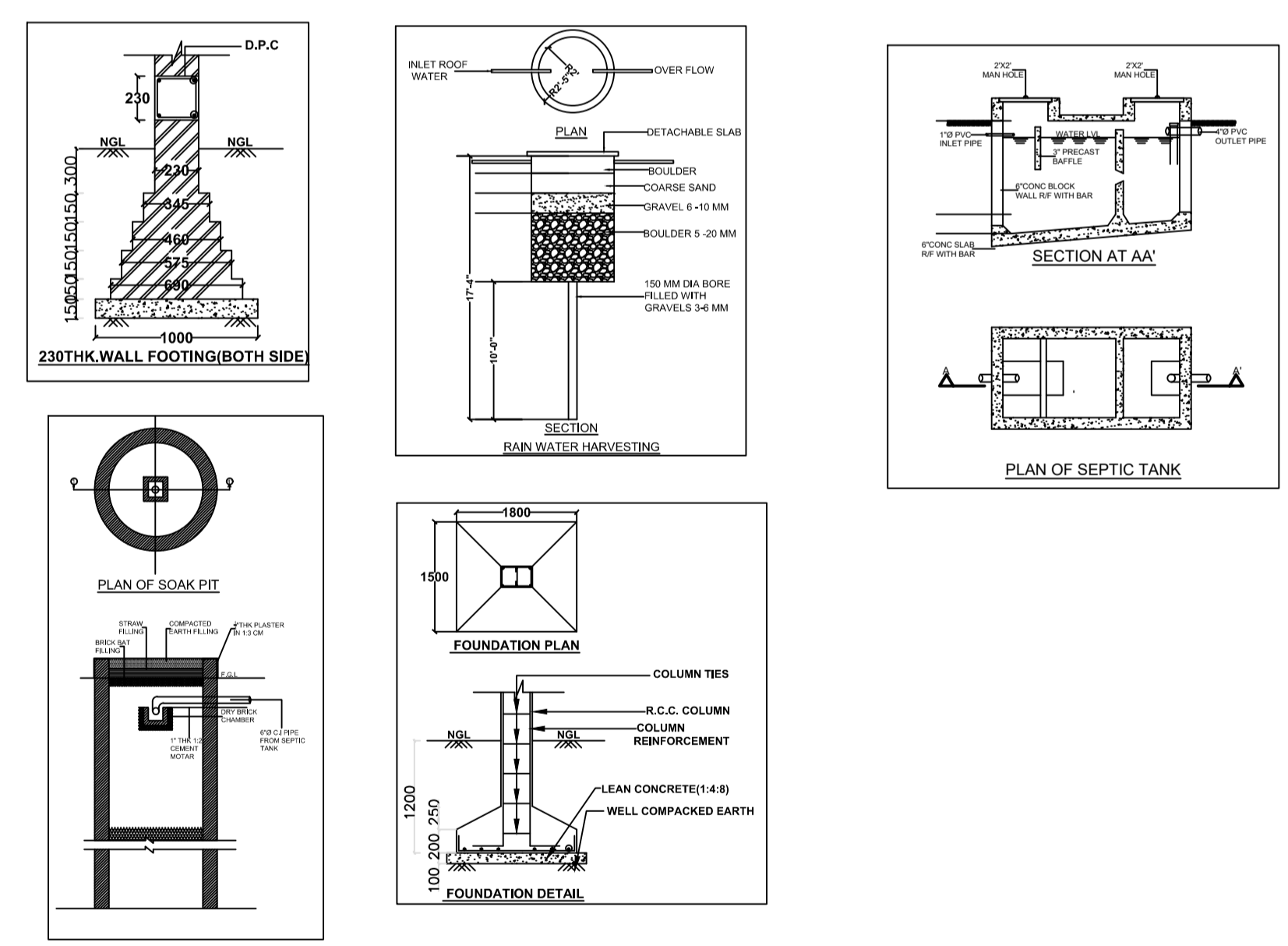
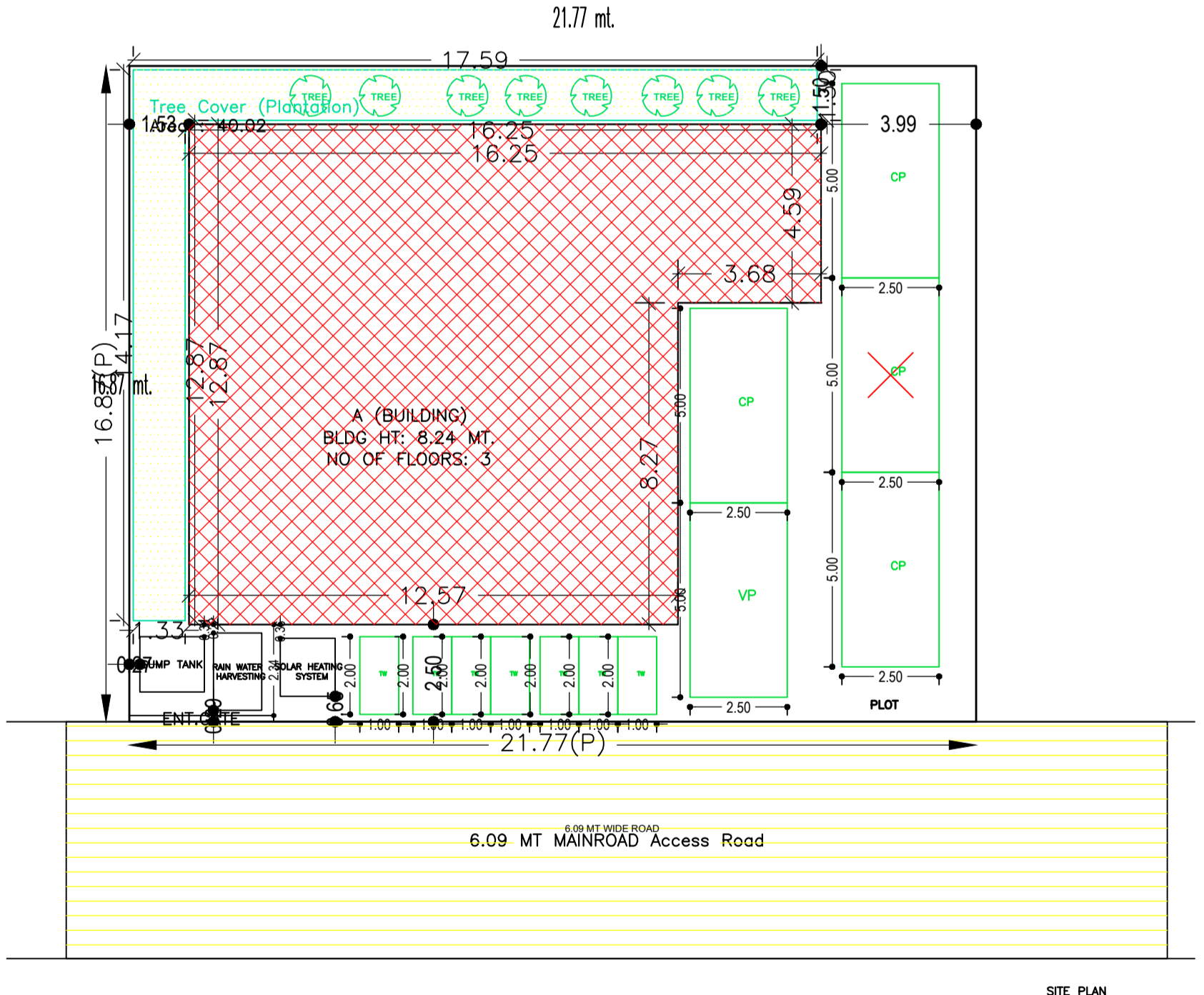

UnitBUA Table for Building :A (BUILDING)

FLOOR	Name	UnitBUA Type	UnitBUA Area	Carpet Area	No. of Rooms	No. of Tenement
GROUND FLOOR PLAN	GROUND FLOOR	FLAT	178.69	159.89	11	1
FIRST FLOOR PLAN	SPLIT FIRST FLOOR	FLAT	178.69	159.89	11	1
SECOND FLOOR PLAN	SPLIT SECOND FLOOR	FLAT	178.69	159.89	11	1
Total:	-	-	536.07	479.67	33	3

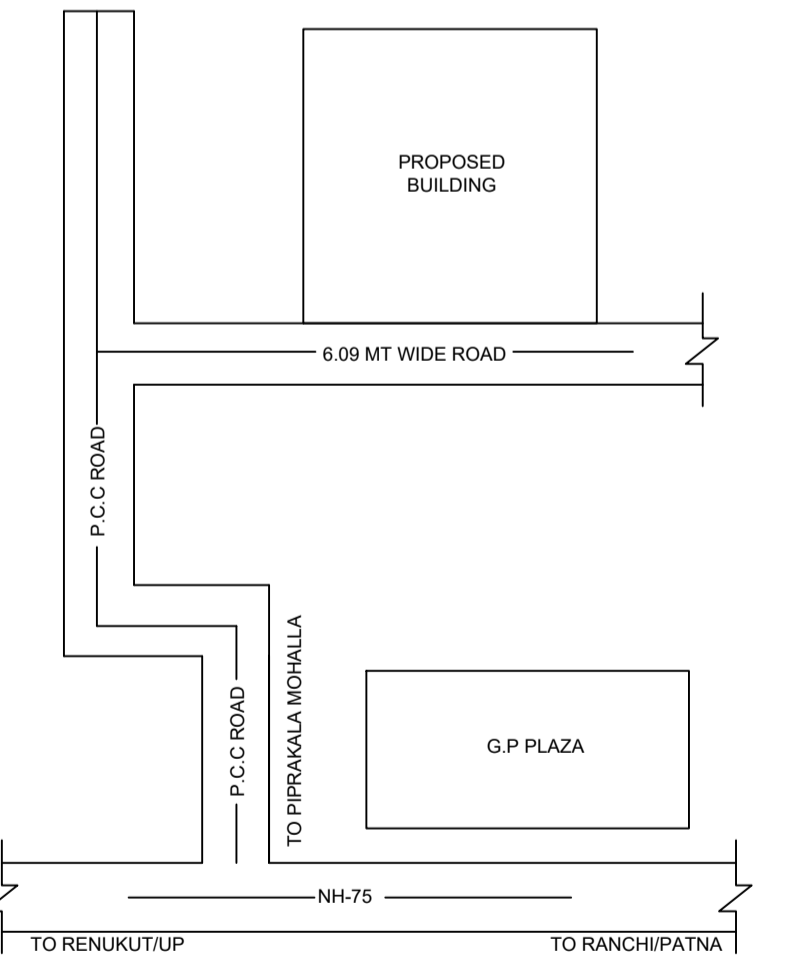

AREA STATEMENT GARHWA NAGAR PARISHAD

Version No.	Version Date	SQ.MT.
1.0.31	30/06/2018	367.24
NET AREA OF PLOT (Gross Plot Area)	(A)	367.24
- Deduction from Gross Plot area)	(A-Deductions)	367.24
Deduction for Balance Plot Area (from Gross Plot Area)		40.02
Common Plot		40.02
Total		40.02
BALANCE AREA OF PLOT (Net Plot Area - Recreational/Amenity space)	(A-Deductions)	327.22
PLOT AREA FOR COVERAGE (Net Plot Area)	(A-Deductions)	367.24
Plot Area for FAR (Net Plot Area + Road/Widening Area)	(A-Deductions)	367.24
COVERAGE CHECK		
Permissible Coverage area ( 60.00 % )		220.34
Proposed Coverage Area ( 48.66 % )		178.69
Total Prop. Coverage Area ( 48.66 % )		178.69
Balance coverage area ( 11.34 % )		41.65
FAR CHECK		
Perm. FAR Area ( 1.80 )		661.03
Total Perm. FAR area		661.03
Residential FAR		536.06
Proposed FAR Area		536.06
Total Proposed FAR Area		536.06
Consumed FAR (Factor)		1.46
Balance FAR Area		124.97
BUILT UP AREA CHECK		
Total Proposed BuiltUp Area		536.07
ARCHITECT (Regd)	PRADEEP KUNTAL KUNTAL	
ENGINEER (Regd)		
SUPERVISOR (Regd)		
OWNER (Regd)	SMT UMA DEVI	
DEVELOPMENT AUTHORITY	LOCAL BODY	

SCHEDULE OF DOOR:

BUILDING NAME	NAME	LENGTH	HEIGHT	NOS
A (BUILDING)	D2	0.75	2.10	06
A (BUILDING)	D1	1.00	2.10	27
A (BUILDING)	D	1.05	2.10	03

SCHEDULE OF WINDOW/VENTILATION:

BUILDING NAME	NAME	LENGTH	HEIGHT	NOS
A (BUILDING)	V1	0.60	1.20	06
A (BUILDING)	W1	1.80	1.20	42

Required Parking (Table 7a)

Building Name	Type	SubUse	Area (Sq.mt.)	Units		Car		Visitors Car		TwoWheeler	
				Reqd.	Prop.	Reqd./Unit	Prop.	Reqd./Unit	Prop.	Reqd./Unit	Prop.
A (BUILDING)	Residential	Bungalow/ Dwelling / Non Apartment	> 0	1	3.00	1	3	-	-	-	-
			> 0	1	3.00	-	-	1	1	-	-
Total :			-	-	-	-	3	4	-	1	7

Parking Check (Table 7b)

Vehicle Type	Reqd.		Prop.	
	No.	Area	No.	Area
Car	-	-	4	50.00
Total Car	3	37.50	4	50.00
Visitor's Car Parking	1	12.50	1	12.50
TwoWheeler	-	-	7	14.00
Total		50.00		76.50

Building :A (BUILDING)

Floor Name	Total Built Up Area (Sq.mt.)	Proposed FAR Area (Sq.mt.)	Total FAR Area (Sq.mt.)	Total Consumed Additional FAR Area (Sq.mt.)	Tnmt (No.)
Ground Floor	178.69	178.69	178.69	178.69	01
First Floor	178.69	178.69	178.69	178.69	01
Second Floor	178.69	178.69	178.69	178.69	01
Terrace Floor	0.00	0.00	0.00	0.00	00
Total :	536.07	536.07	536.07	536.07	03
Total Number of Same Buildings :	1				
Total :	536.07	536.07	536.07	536.07	03

LTP NAME AND SIGNATURE

PRADEEP KUNTAL KUNTAL GNPC/ARC/0007/2017	STRUCTURAL ENG'S NAME AND SIGNATURE	BUILDER NAME AND SIGNATURE	DIGITAL SIGNATURE
---	-------------------------------------	----------------------------	-------------------