

Proposal Basic Information	
Proposal File No.	GNPC/BP/0022/W04/2019
Owner Name	SMT KIRAN GUPTA
Khata No	35
Plot No	127
Village Name	Nagwa
Use	Residential
SubUse	Bungalow/ Dwelling / Non Apartment

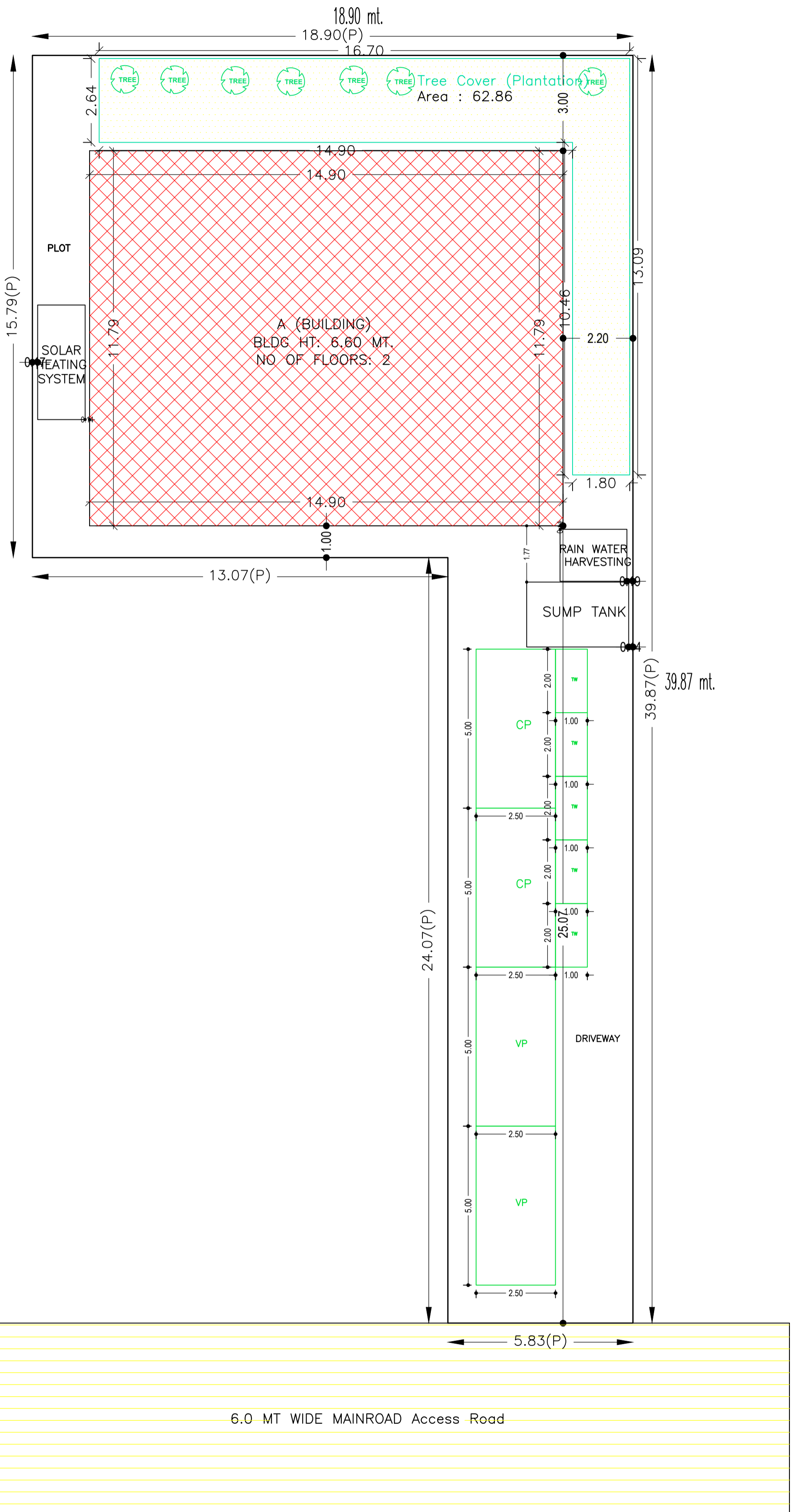

SITE PLAN

Required Parking (Table 7a)

Building Name	Type	SubUse	Area (Sq.mt.)	Units		Car		Visitors Car		TwoWheeler	
				Reqd.	Prop.	Reqd./Unit	Reqd.	Prop.	Reqd./Unit	Reqd.	Prop.
A (BUILDING)	Residential	Bungalow/ Dwelling / Non Apartment	> 0	1	2.00	1	2	-	-	-	-
			> 0	1	2.00	-	-	1	1	-	-
Total :			-	-	-	-	2	2	1	2	0

Parking Check (Table 7b)

Vehicle Type	Reqd.		Prop.	
	No.	Area	No.	Area
Car	-	-	2	25.00
Total Car	2	25.00	2	25.00
Visitor's Car Parking	-	-	2	25.00
Total Visitor Parking	1	12.50	2	25.00
TwoWheeler	-	-	5	10.00
Total TwoWheeler	-	-	5	10.00
Total		37.50		95.00

Building USE/SUBUSE Details

Building Name	Building Use	Building SubUse	Building Structure
A (BUILDING)	Residential	Bungalow/ Dwelling / Non Apartment	Non-Highrise

FAR & Tenement Details (Table 4c-1)

Building	No. of Same Bldg	Total Built Up Area (Sq.mt.)	Proposed FAR Area (Sq.mt.)	Total FAR Area (Sq.mt.)	Total Consumed Additional FAR Area (Sq.mt.)	Tnmt (No.)
A (BUILDING)	1	351.44	351.44	351.44	351.44	02
Grand Total :	1	351.44	351.44	351.44	351.44	02

Floor No	Building Name		Total	
	Proposed Built Up Area (Sq.mt.)	Proposed FAR Area (Sq.mt.)	Total Proposed Built Up Area (Sq.mt.)	Total FAR Area (Sq.mt.)
Ground Floor	175.72	175.72	175.72	175.72
First Floor	175.72	175.72	175.72	175.72
Terrace Floor	0.00	0.00	0.00	0.00
Total :	351.44	351.44	351.44	351.44

COLOR INDEX	
PLOT BOUNDARY	Black
ABUTTING ROAD	Green
PROPOSED CONSTRUCTION	Red
COMMON PLOT	Yellow
ROAD WIDENING AREA	Orange
EXISTING (To be retained)	Blue
EXISTING (To be demolished)	Light Blue

AREA STATEMENT GARHWA NAGAR PARISHAD	VERSION NO. : 1.0.36
PROJECT DETAIL:	VERSION DATE: 29/04/2019
Region: JHARKHAND URBAN	Plot Use: Residential
District: GARHWA	Plot SubUse: Bungalow/ Dwelling / Non Apartment
Authority: GARHWA NAGAR PARISHAD	PlotNearbyReligiousStructure: NA
Inward No: GNPC/BP/0022/W04/2019	Plot/SubPlot No: 127
Application Type: General Proposal	North: Road Width - 6
Project Type: Building Permission	South: Plot No. - 127
Nature of Development: New	East: Plot No. - 127
Location of Development Area: Old Area	West: Plot No. - 127
AREA DETAILS:	SQ.MT.
AREA OF PLOT (Minimum)	(A) 438.76
NET AREA OF PLOT (Gross Plot Area - Deduction from Gross Plot area)	(A-Deductions) 438.76
Deduction for Balance Plot Area (from Gross Plot Area)	
Common Plot	62.86
Total	62.86
BALANCE AREA OF PLOT (Net Plot Area - Recreational/Amenity space)	(A-Deductions) 375.90
PLOT AREA FOR COVERAGE (Net Plot Area)	(A-Deductions) 438.76
Plot Area for FAR (Net Plot Area + RoadWidening Area)	(A-Deductions) 438.76
COVERAGE CHECK	
Permissible Coverage area (60.05 %)	263.26
Proposed Coverage Area (40.05 %)	175.72
Total Prop. Coverage Area (40.05 %)	175.72
Balance coverage area (19.95 %)	87.54
FAR CHECK	
Perm. FAR Area (1.80)	789.77
Total Perm. FAR area	789.77
Residential FAR	351.44
Proposed FAR Area	351.44
Total Proposed FAR Area	351.44
Consumed FAR (Factor)	0.80
Balance FAR Area	438.33
BUILT UP AREA CHECK	
Total Proposed BuiltUp Area	351.44
ARCHITECT (Regd)	PRADEEP KUNTAL KUNTAL
ENGINEER (Regd)	
SUPERVISOR (Regd)	
OWNER (Regd)	SMT KIRAN GUPTA
DEVELOPMENT AUTHORITY	LOCAL BODY

LTP NAME AND SIGNATURE	STRUCTURAL ENG'S NAME AND SIGNATURE	BUILDER NAME AND SIGNATURE	DIGITAL SIGNATURE
PRADEEP KUNTAL KUNTAL GNPC/ARC/0007/2017			

Proposal Basic Information	
Proposal File No.	GNPC/BP/0022/W04/2019
Owner Name	SMT KIRAN GUPTA
Khata No	35
Plot No	127
Village Name	Nagwa
Use	Residential
SubUse	Bungalow/ Dwelling / Non Apartment

SCHEDULE OF DOOR:

BUILDING NAME	NAME	LENGTH	HEIGHT	NOS
A (BUILDING)	D2	0.75	2.10	04
A (BUILDING)	D1	1.00	2.10	20
A (BUILDING)	D	1.05	2.10	02

SCHEDULE OF WINDOW/VENTILATION:

BUILDING NAME	NAME	LENGTH	HEIGHT	NOS
A (BUILDING)	V1	0.60	1.20	04
A (BUILDING)	W1	1.80	1.20	19

Building :A (BUILDING)

Floor Name	Total Built Up Area (Sq.mt.)	Proposed FAR Area (Sq.mt.)	Total FAR Area (Sq.mt.)	Total Consumed Additional FAR Area (Sq.mt.)	Trmt (No.)
Ground Floor	175.72	175.72	175.72	175.72	01
First Floor	175.72	175.72	175.72	175.72	01
Terrace Floor	0.00	0.00	0.00	0.00	00
Total :	351.44	351.44	351.44	351.44	02
Total Number of Same Buildings :	1				
Total :	351.44	351.44	351.44	351.44	02

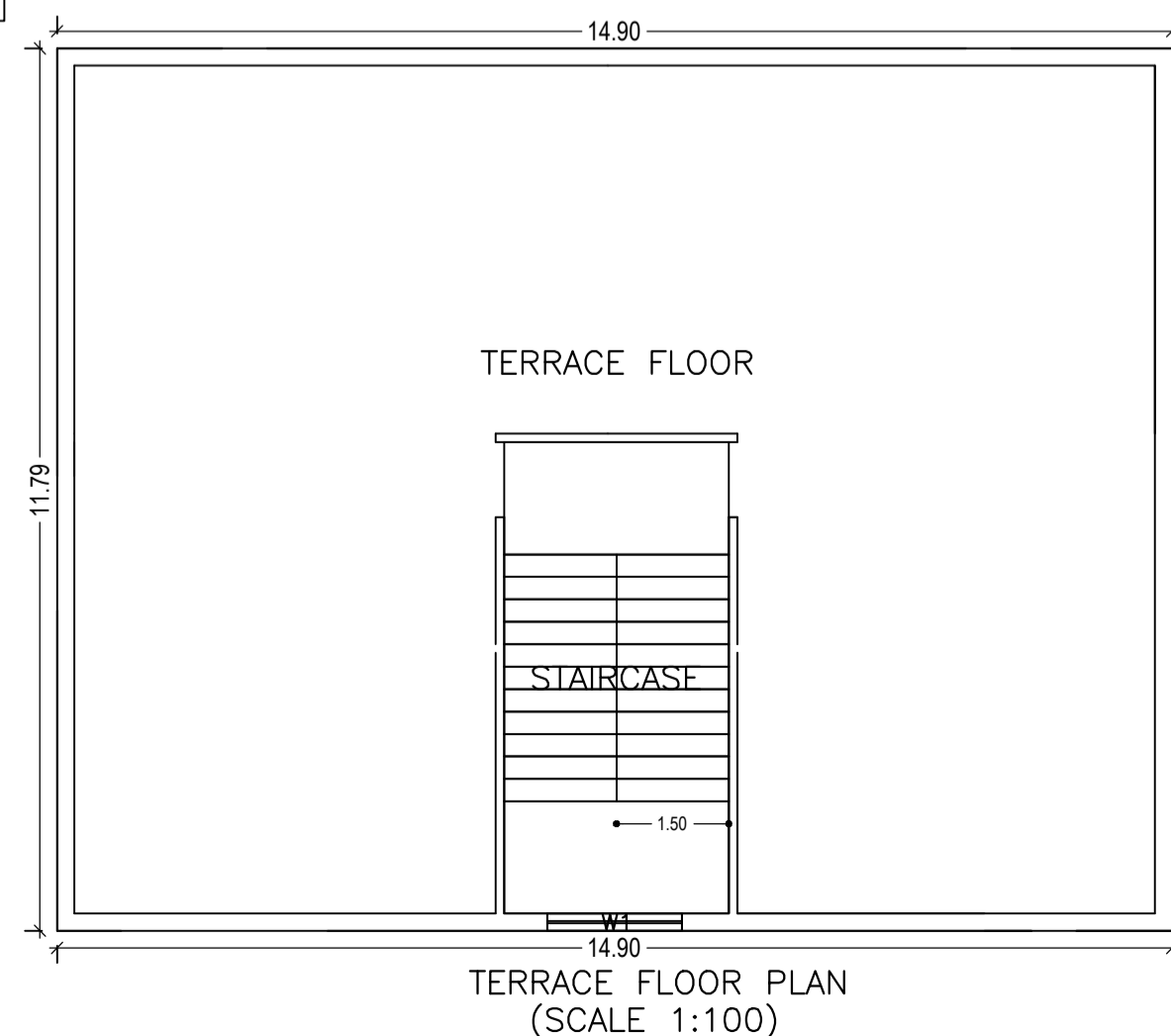
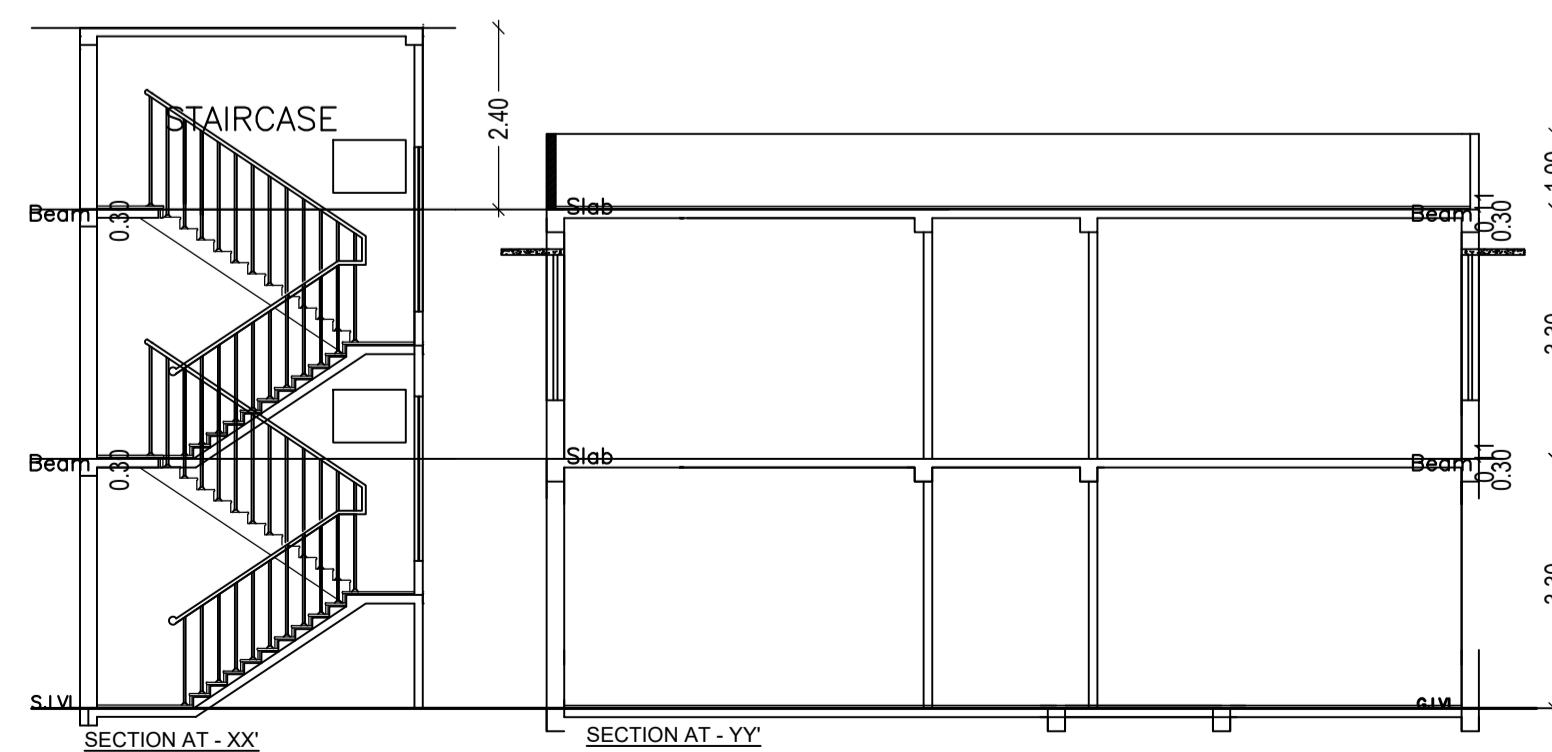
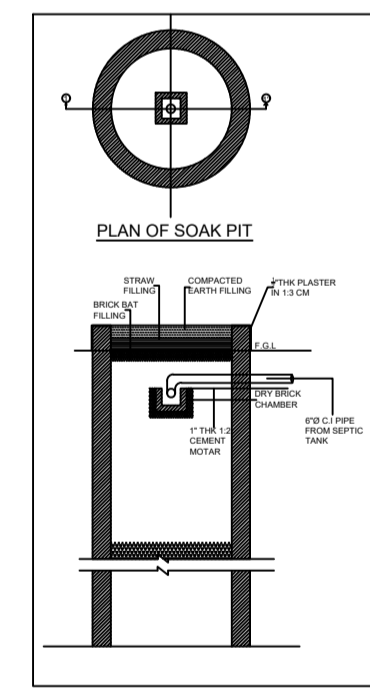
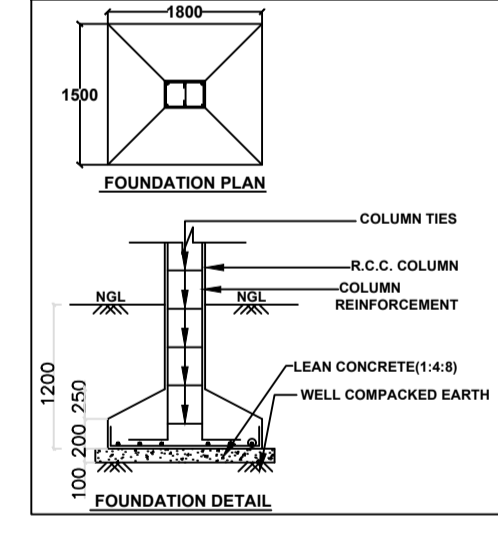
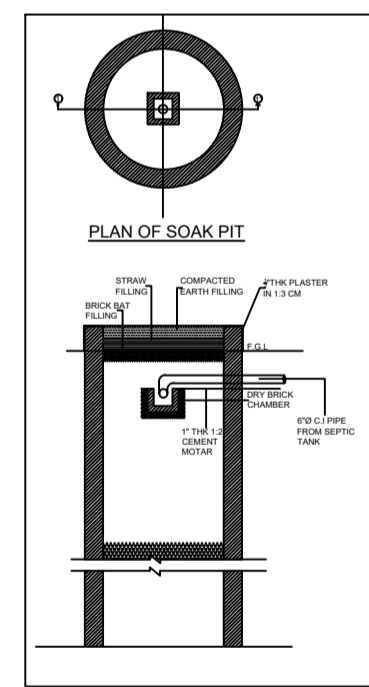
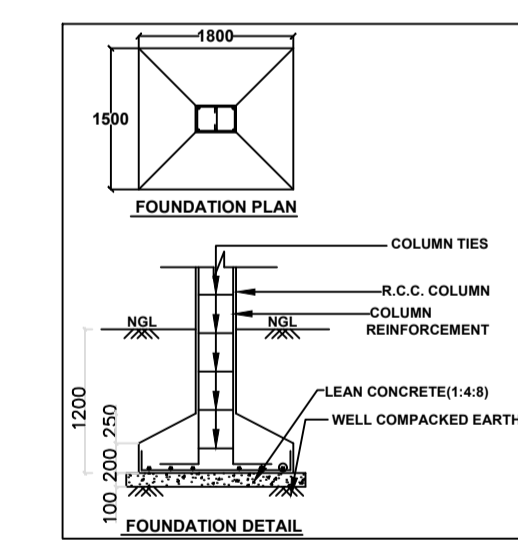
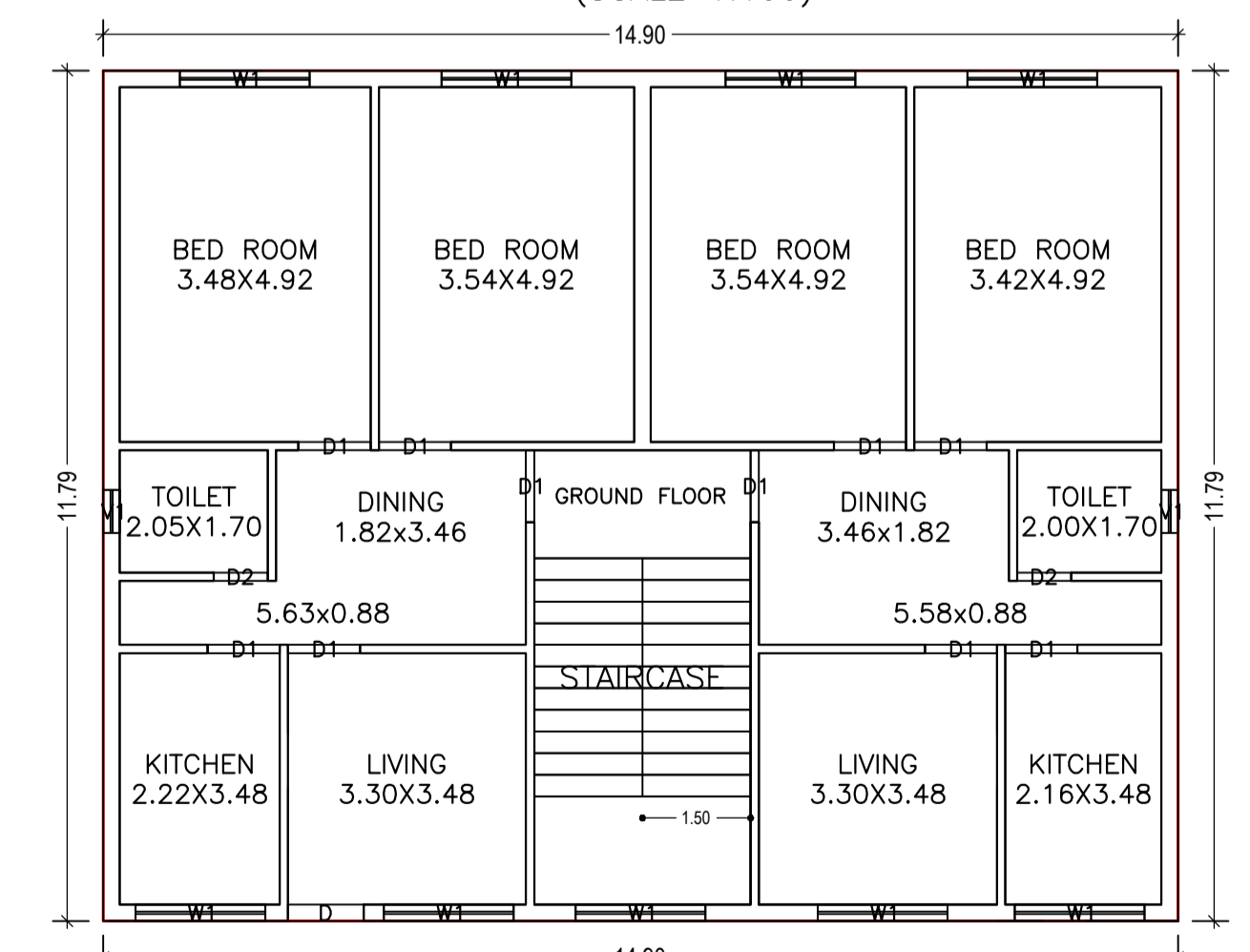
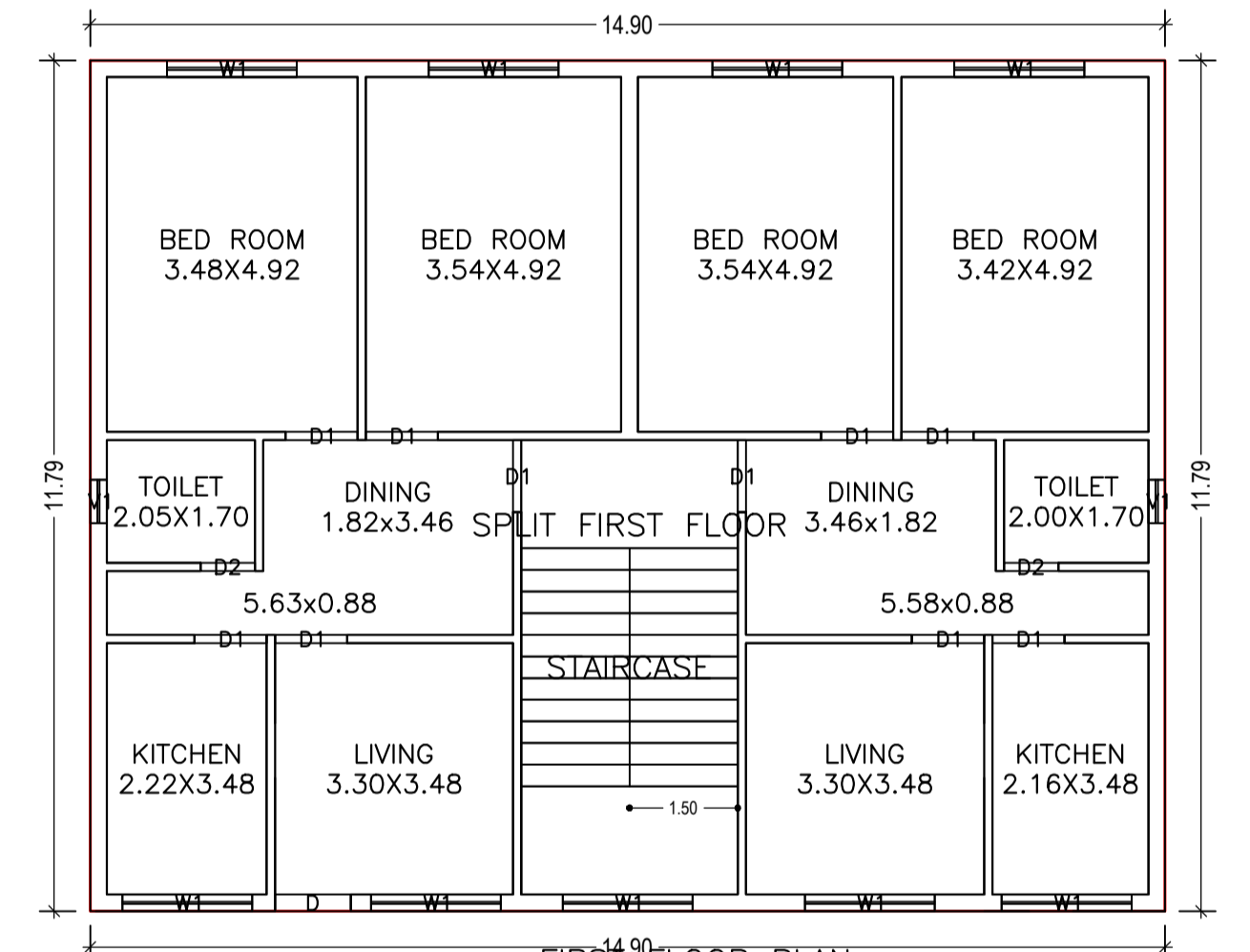
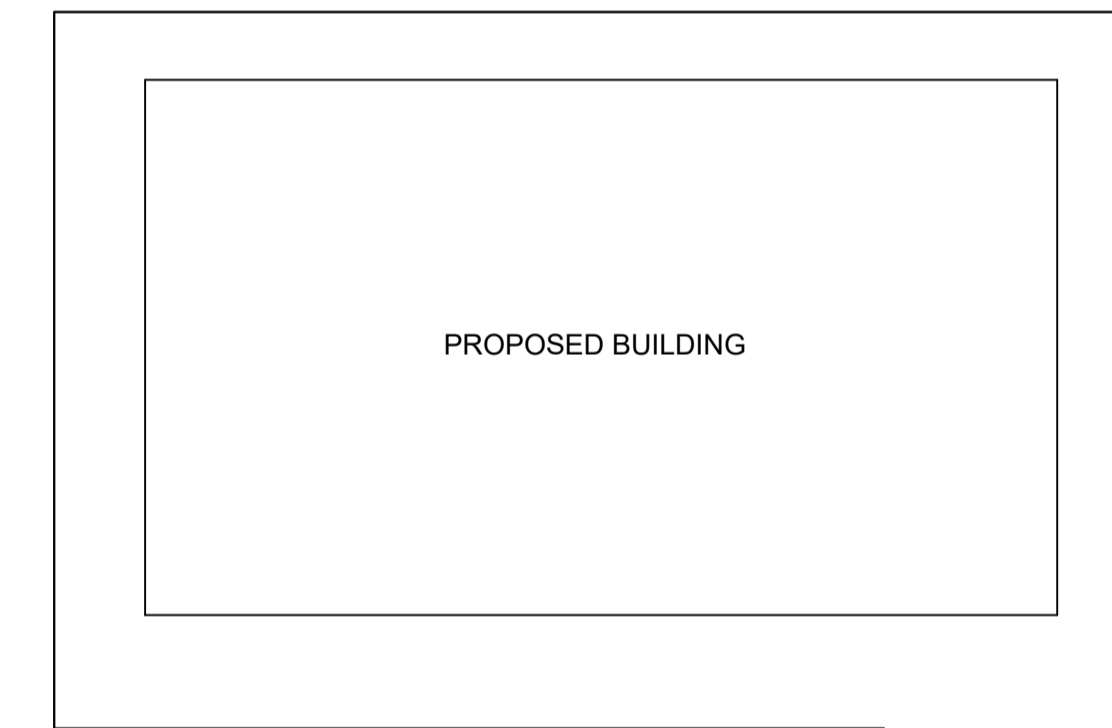
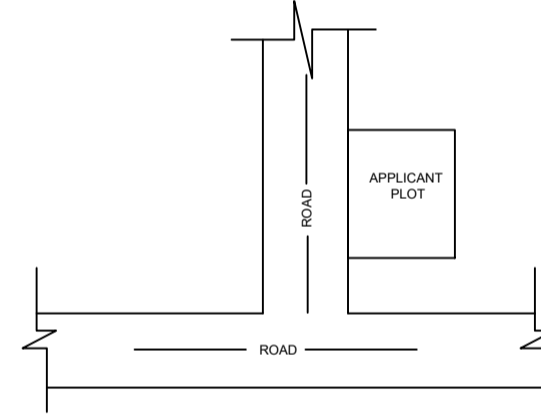
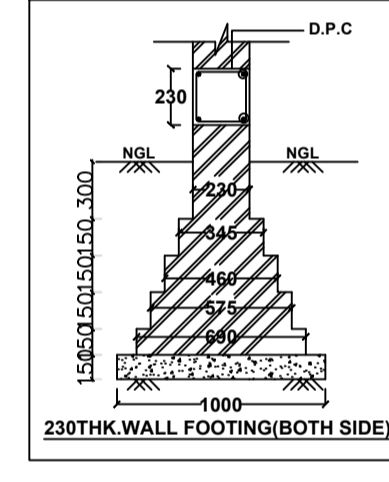
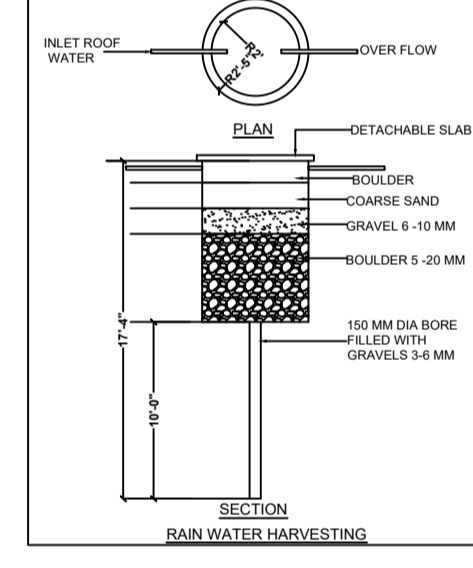
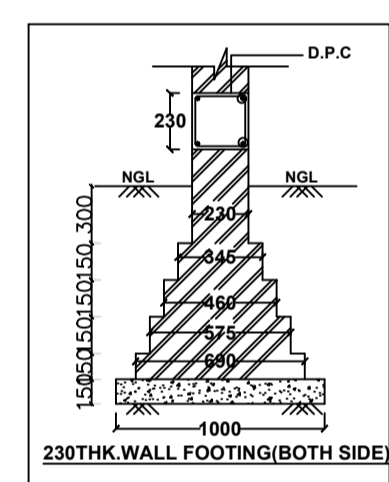
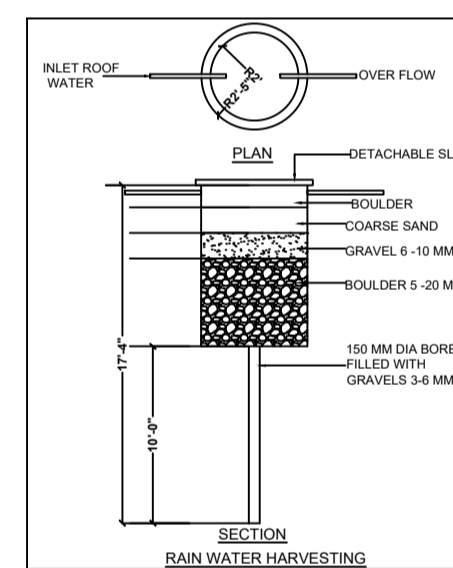
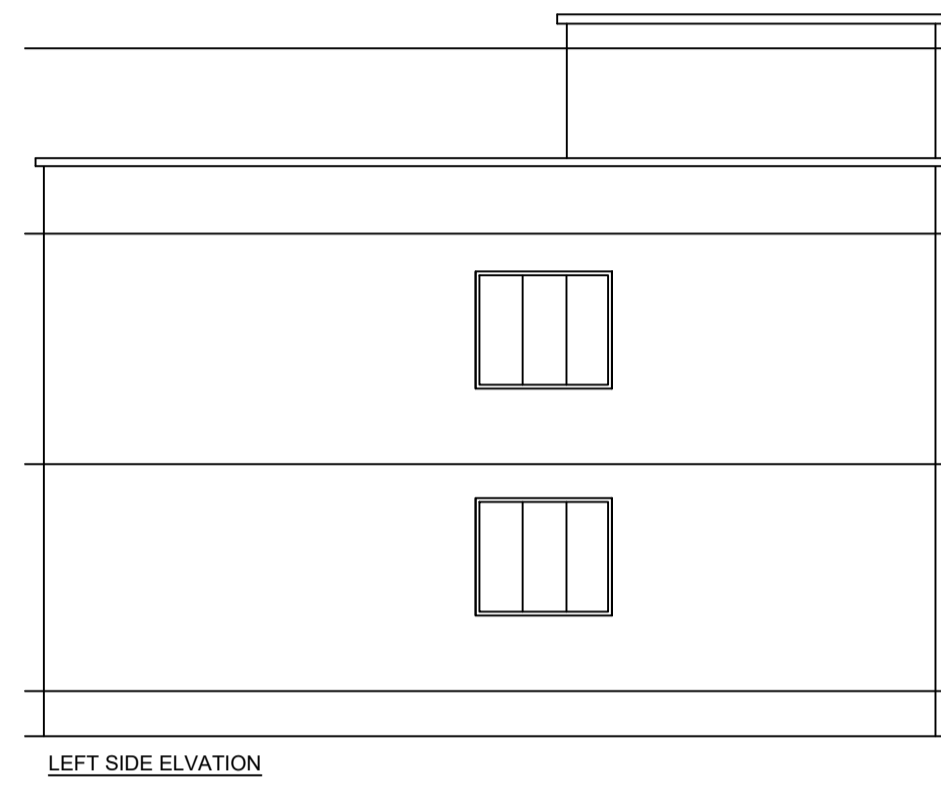
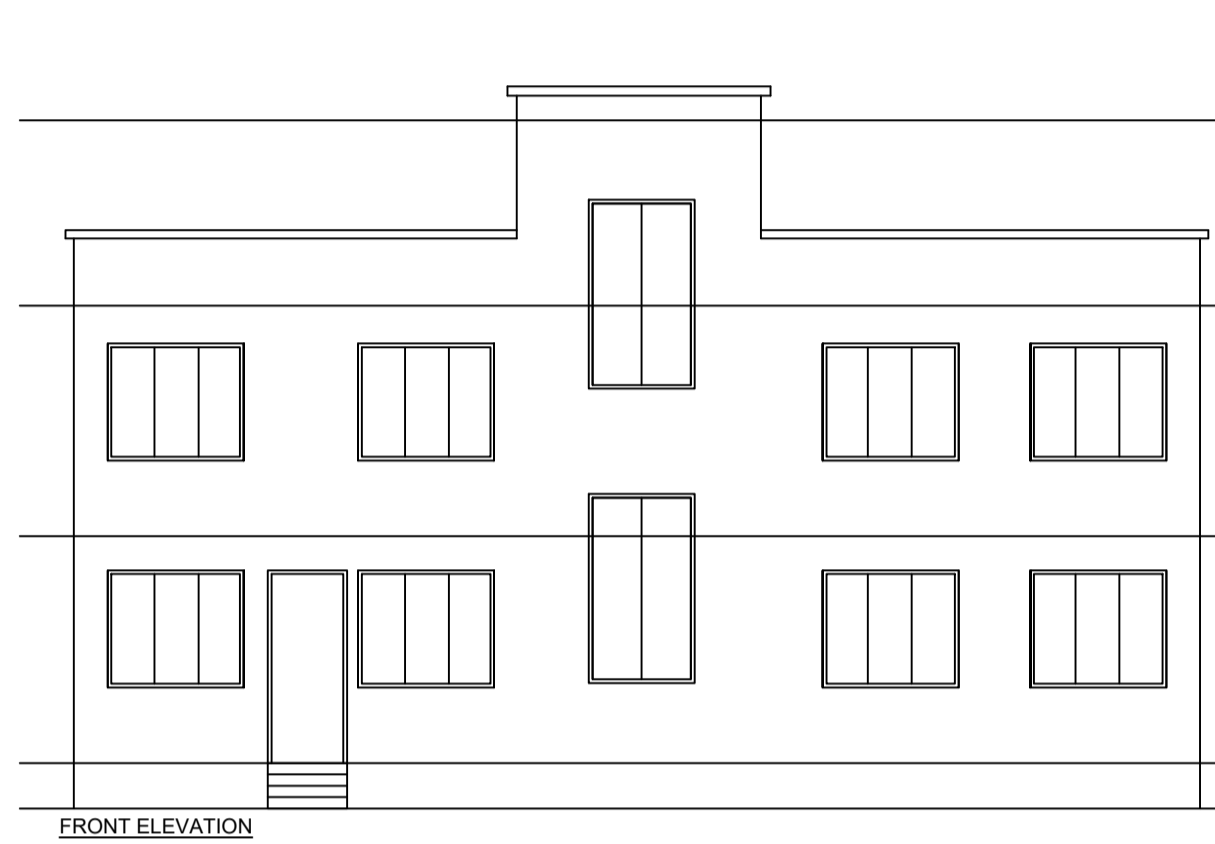

LOCATION PLAN

UnitBUA Table for Building :A (BUILDING)

FLOOR	Name	UnitBUA Type	UnitBUA Area	Carpet Area	No. of Rooms	No. of Tenement
FIRST FLOOR PLAN	SPLIT FIRST FLOOR	FLAT	175.72	156.87	12	1
GROUND FLOOR PLAN	GROUND FLOOR	FLAT	175.72	156.87	12	1
Total:	-	-	351.44	313.74	24	2

LTP NAME AND SIGNATURE	STRUCTURAL ENG'S NAME AND SIGNATURE	BUILDER NAME AND SIGNATURE	DIGITAL SIGNATURE
PRADEEP KUNTAL KUNTAL GNPC/ARC/0007/2017			