

Proposal Basic Information	
Proposal File No.	GNPC/BP/0040/W14/2020
Owner Name	SMT KRISHNA DEVI
Khata No	60
Plot No	683
Village Name	Sahijana
Use	Residential
SubUse	Bungalow/ Dwelling / Non Apartment

UnitBUA Table for Building :A (BUILDING)

FLOOR	Name	UnitBUA Type	UnitBUA Area	Carpet Area	No. of Rooms	No. of Tenement
GROUND FLOOR	FLAT		82.04	72.33	5	1
Total:	-	-	82.04	72.33	5	1

Building :A (BUILDING)

Floor Name	Total Built Up Area (Sq.mt.)	Proposed FAR Area (Sq.mt.)	Total FAR Area (Sq.mt.)	Total Consumed Additional FAR Area (Sq.mt.)	Tnmt (No.)
Ground Floor	82.04	82.04	82.04	82.04	01
Terrace Floor	0.00	0.00	0.00	0.00	00
Total :	82.04	82.04	82.04	82.04	01
Total Number of Same Buildings :	1				
Total :	82.04	82.04	82.04	82.04	01

SCHEDULE OF DOOR:

BUILDING NAME	NAME	LENGTH	HEIGHT	NOS
A (BUILDING)	D2	0.75	2.10	01
A (BUILDING)	D1	1.00	2.10	04
A (BUILDING)	D	1.05	2.10	01

SCHEDULE OF WINDOW/VENTILATION:

BUILDING NAME	NAME	LENGTH	HEIGHT	NOS
A (BUILDING)	V1	0.60	1.20	01
A (BUILDING)	W1	1.80	1.20	04

FAR & Tenement Details (Table 4c-1)

Building	No. of Same Bldg	Total Built Up Area (Sq.mt.)	Proposed FAR Area (Sq.mt.)	Total FAR Area (Sq.mt.)	Total Consumed Additional FAR Area (Sq.mt.)	Tnmt (No.)
A (BUILDING)	1	82.04	82.04	82.04	82.04	01
Grand Total :	1	82.04	82.04	82.04	82.04	01

Building USE/SUBUSE Details

Building Name	Building Use	Building SubUse	Building Structure
A (BUILDING)	Residential	Bungalow/ Dwelling / Non Apartment	Non-Highrise

Buildingwise Floor FAR Details

Floor Name	Building Name A (BUILDING)		Total	
	Proposed Built Up Area (Sq.mt.)	Proposed FAR Area (Sq.mt.)	Total Proposed Built Up Area (Sq.mt.)	Total FAR Area (Sq.mt.)
Ground Floor	82.04	82.04	82.04	82.04
Terrace Floor	0.00	0.00	0.00	0.00
Total :	82.04	82.04	82.04	82.04

COLOR INDEX

PLOT BOUNDARY	Black
ABUTTING ROAD	Green
PROPOSED CONSTRUCTION	Red
COMMON PLOT	Yellow
ROAD WIDENING AREA	Orange
EXISTING (To be retained)	Blue
EXISTING (To be demolished)	Light Blue

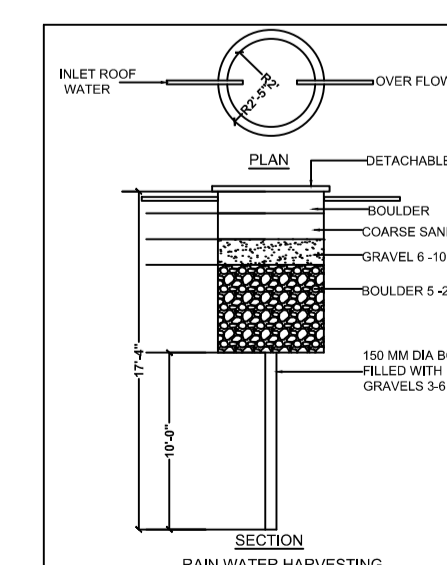
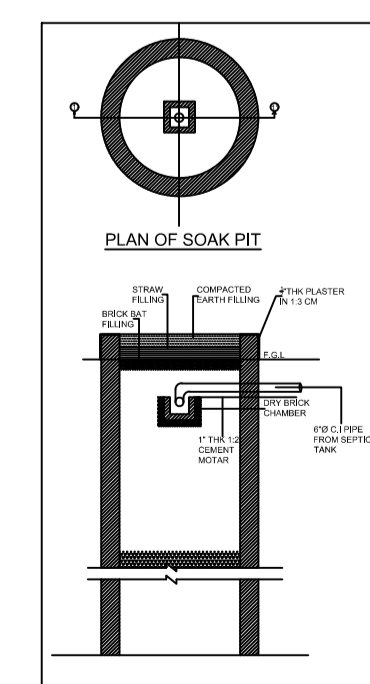
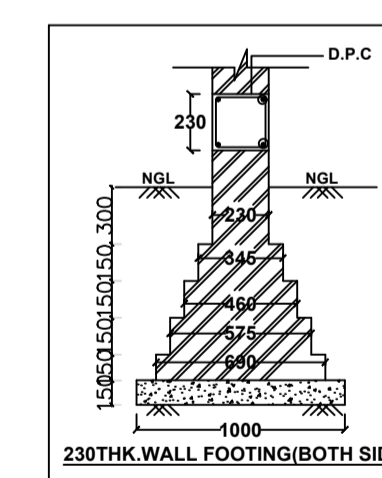
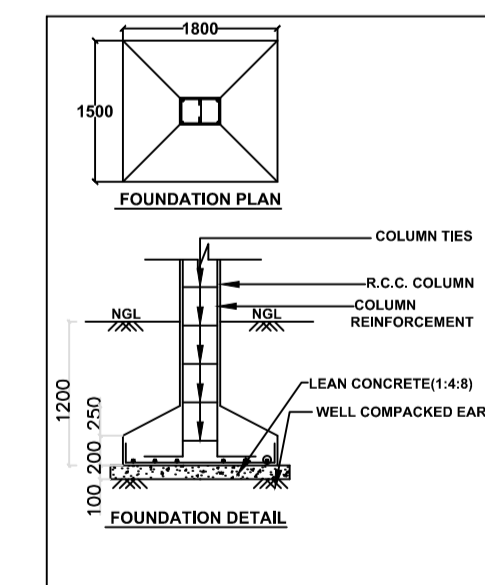
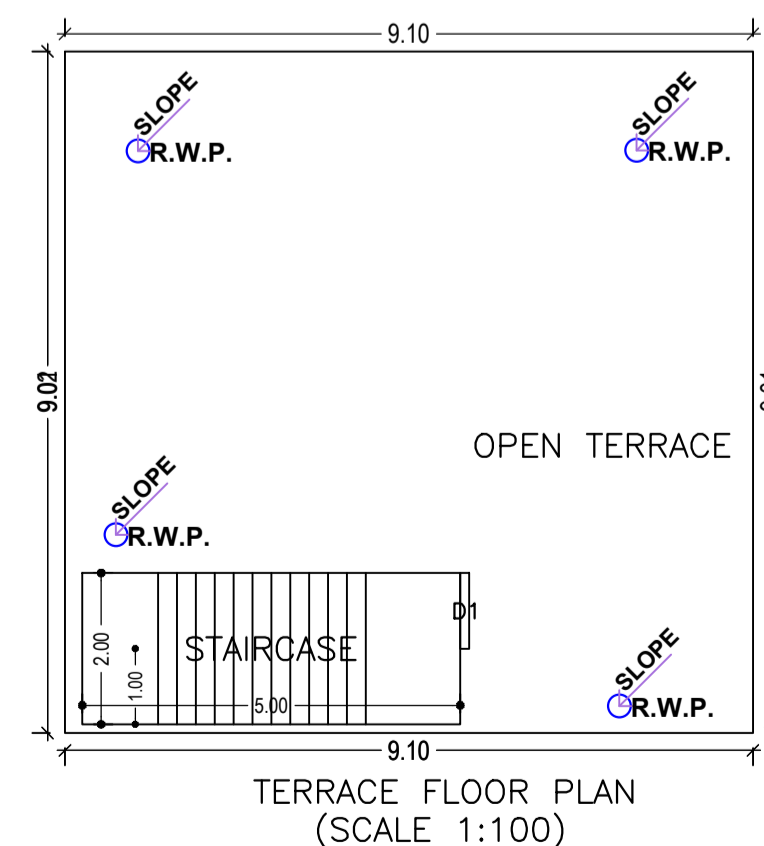
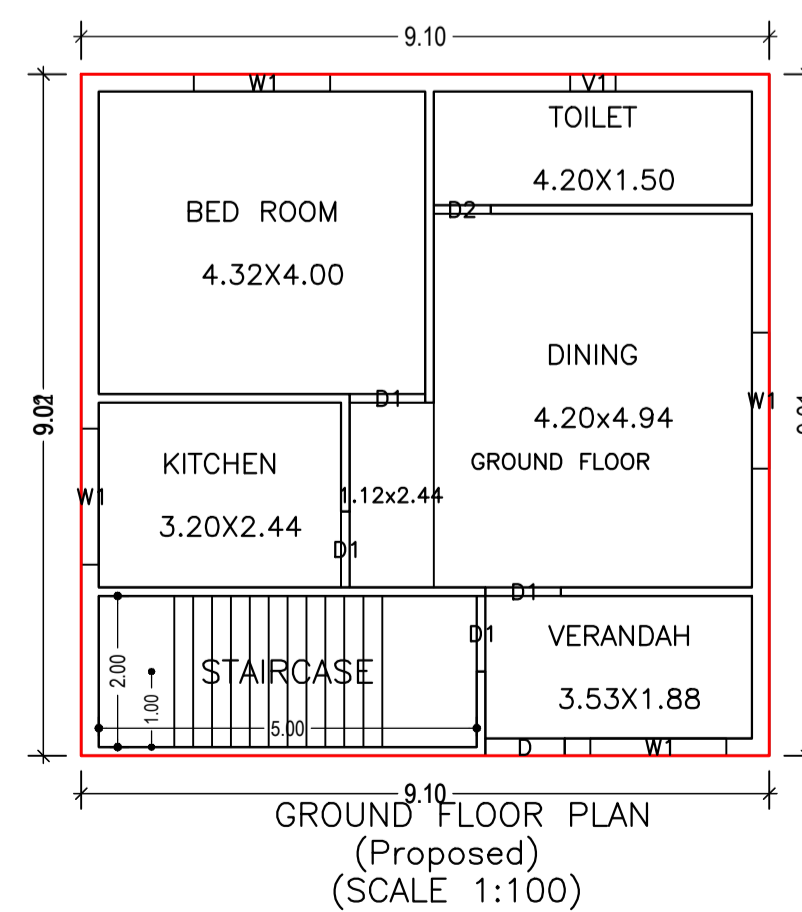
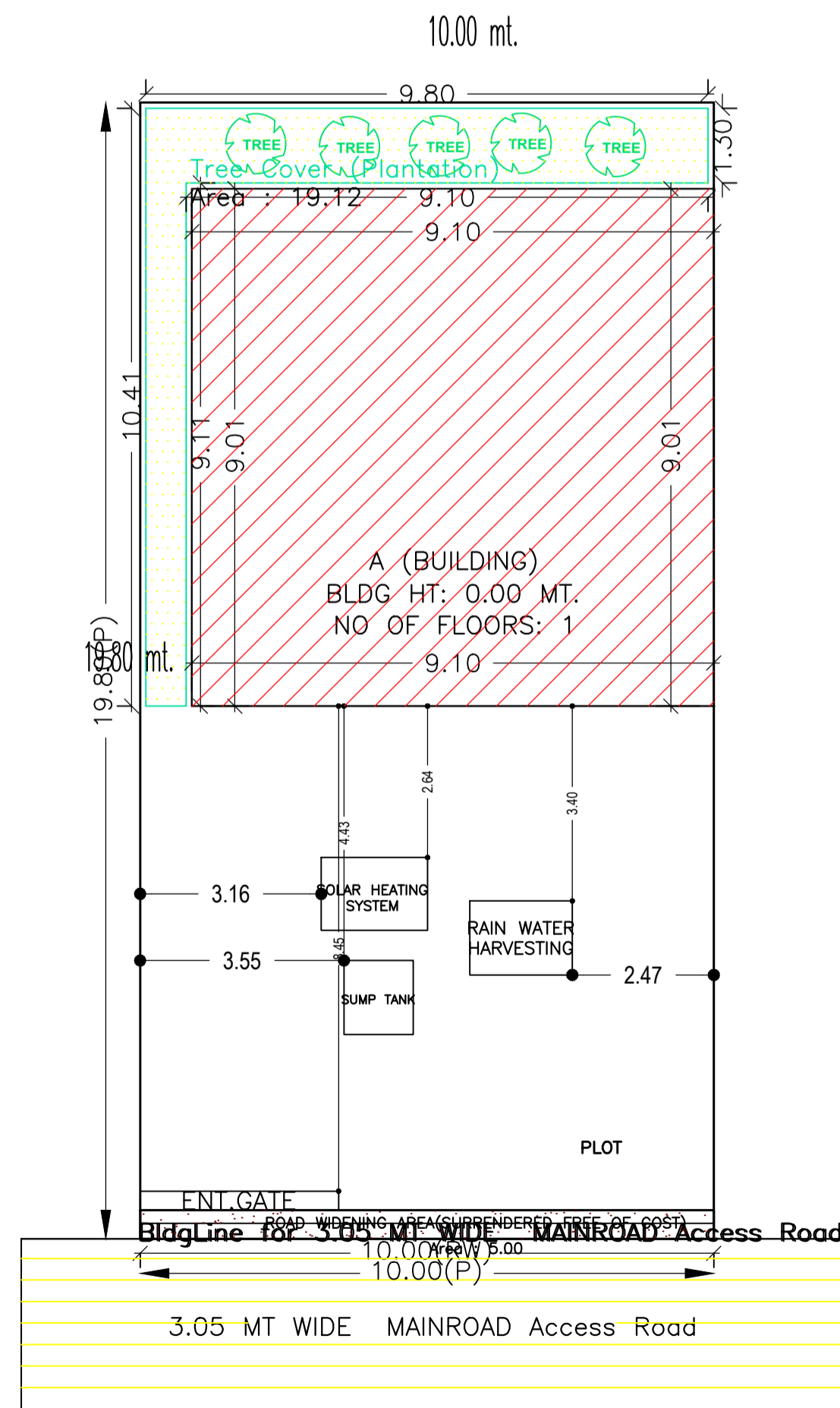
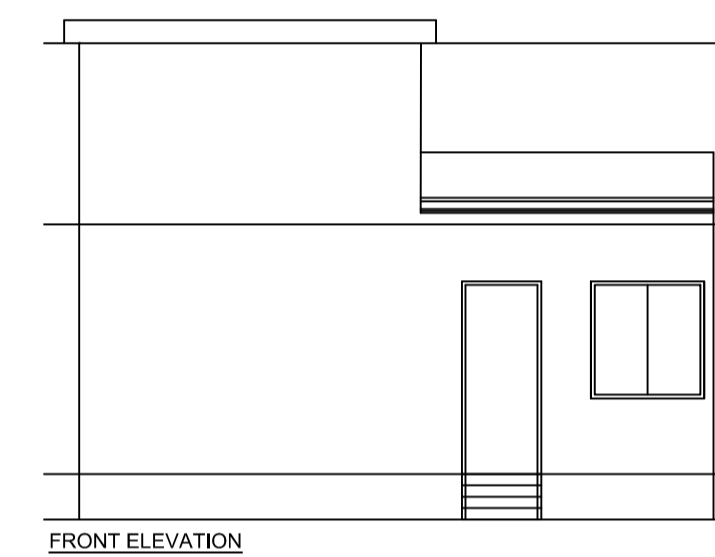
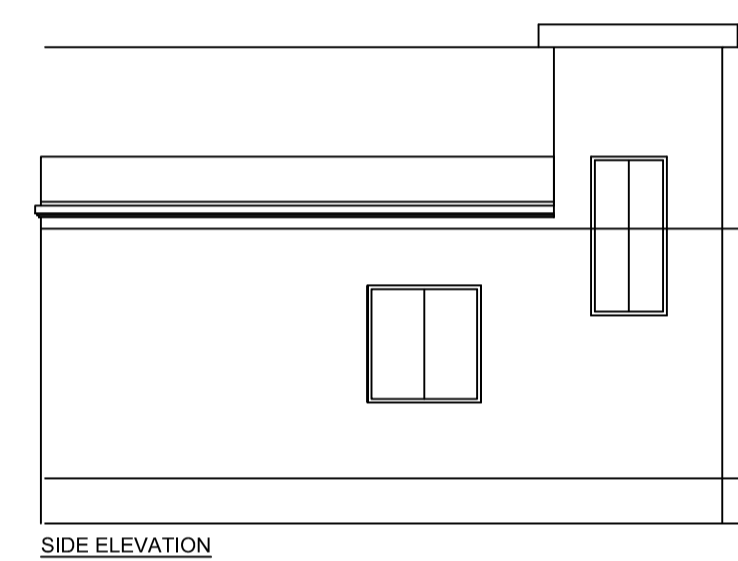
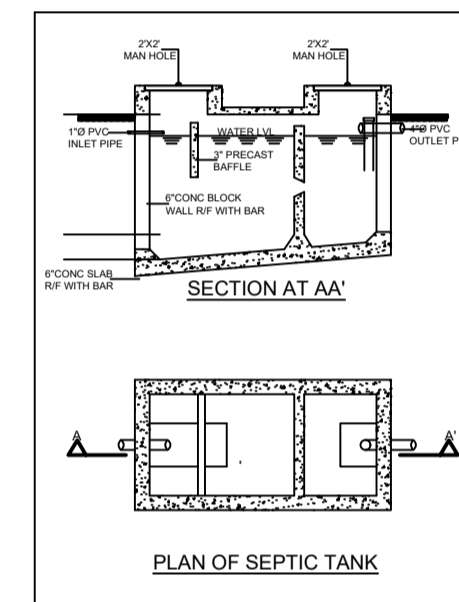
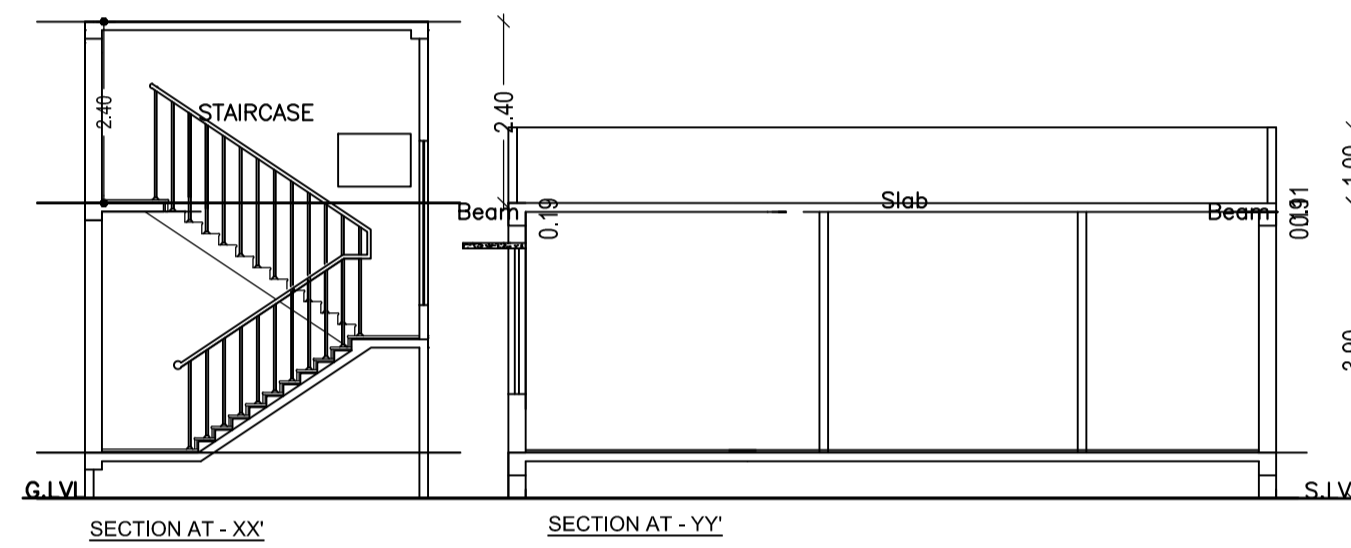

AREA STATEMENT GARHWA NAGAR PARISHAD		VERSION NO.: 1.0.50
PROJECT DETAIL:		VERSION DATE: 16/10/2020
Region: JHARKHAND URBAN	Plot Use: Residential	
Local Bodies: Distric: GARHWA	Plot SubUse: Bungalow/ Dwelling / Non Apartment	
Authority: GARHWA NAGAR PARISHAD	PlotNearbyReligiousStructure: NA	
Inward No: GNPC/BP/0040/W14/2020	Plot/SubPlot No: 683	
Application Type: General Proposal	North: Plot No. - 683	
Project Type: Building Permission	South: Plot No. - 683	
Nature of Development: New	East: Road Width - 3.05	
Location of Development Area: Old Area	West: Plot No. - 683	
AREA DETAILS:		SQ.MT.
AREA OF PLOT (Minimum)	(A)	198.00
Deduction for NetPlot Area		
Surrender Free of Cost		5.00
Total		5.00
NET AREA OF PLOT(Gross Plot Area - Deduction from Gross Plot area)	(A-Deductions)	193.00
Deduction for Balance Plot Area(from Gross Plot Area)		
Surrender Free of Cost		5.00
Common Plot		19.12
Total		24.12
BALANCE AREA OF PLOT(Net Plot Area - Recreational/Amenity space)	(A-Deductions)	173.88
PLOT AREA FOR COVERAGE(Net Plot Area)	(A-Deductions)	193.00
Plot Area for FAR (Net Plot Area + RoadWidening Area)	(A-Deductions)	198.00
COVERAGE CHECK		
Permissible Coverage area (70.00 %)		135.10
Proposed Coverage Area (42.51 %)		82.04
Total Prop. Coverage Area (42.51 %)		82.04
Balance coverage area (27.49 %)		53.06
FAR CHECK		
Perm. FAR Area (1.20)		237.60
Total Perm. FAR area		237.60
Residential FAR		82.04
Proposed FAR Area		82.04
Total Proposed FAR Area		82.04
Consumed FAR (Factor)		0.41
Balance FAR Area		155.56
BUILT UP AREA CHECK		
Total Proposed BuiltUp Area		82.04
ARCHITECT (Regd)	KUMARI MEENAKSHI TIWARI	
ENGINEER (Regd)		
SUPERVISOR (Regd)		
OWNER (Regd)	SMT KRISHNA DEVI	
DEVELOPMENT AUTHORITY	LOCAL BODY	

LTP NAME AND SIGNATURE	STRUCTURAL ENG'S NAME AND SIGNATURE	BUILDER NAME AND SIGNATURE	DIGITAL SIGNATURE
KUMARI MEENAKSHI TIWARI GNPC/ENG/0006/2019			