

Proposal Basic Information

Proposal File No.	GNPC/BP/0029/W13/2020
Owner Name	SHRI VIKASH KUMAR TIWARY
Khata No	1
Plot No	544
Village Name	Sahijana
Use	Residential
SubUse	Bungalow/ Dwelling / Non Apartment

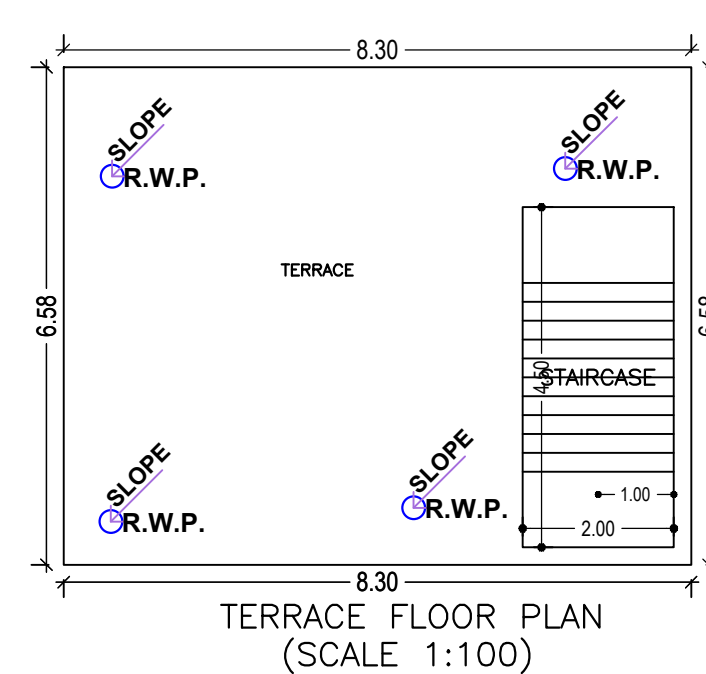
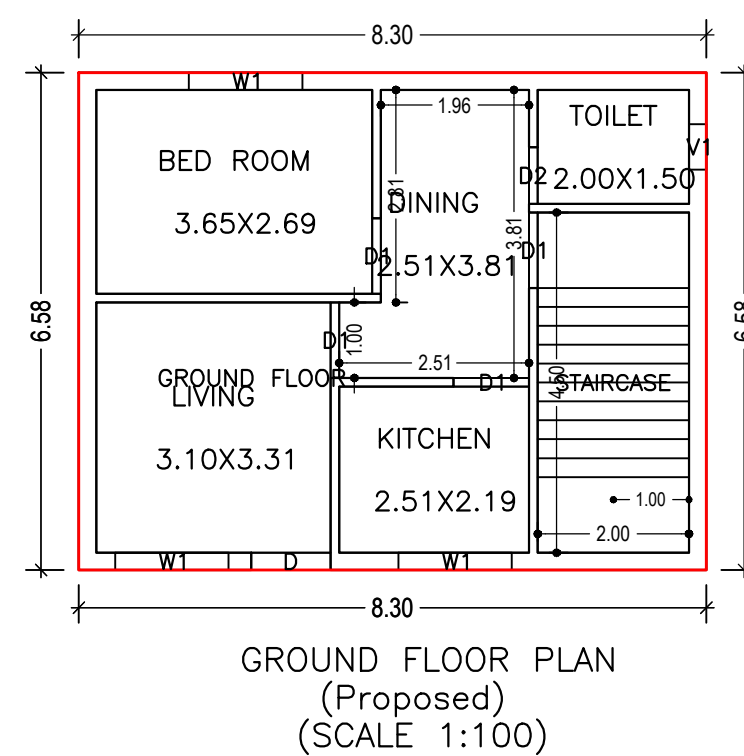
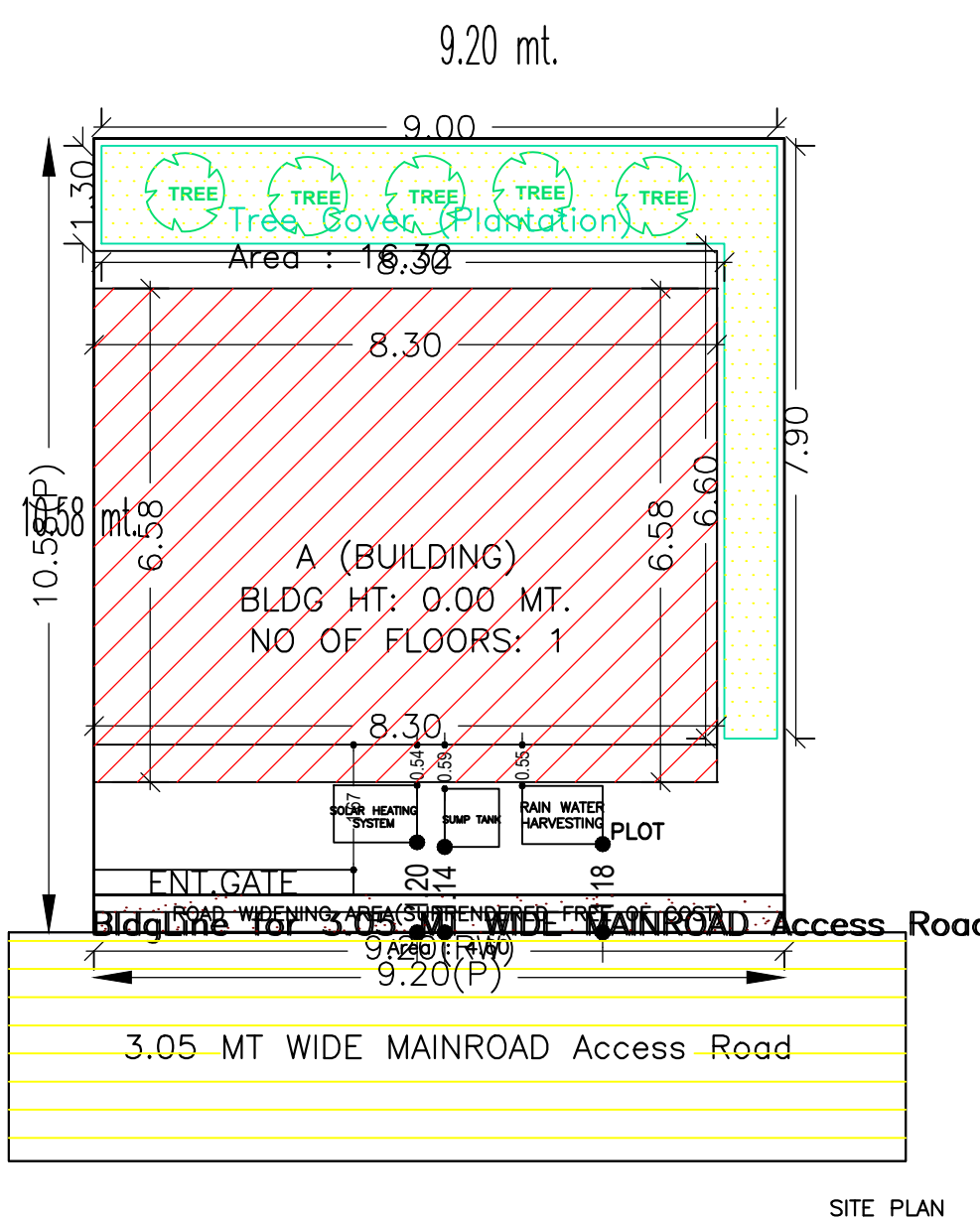
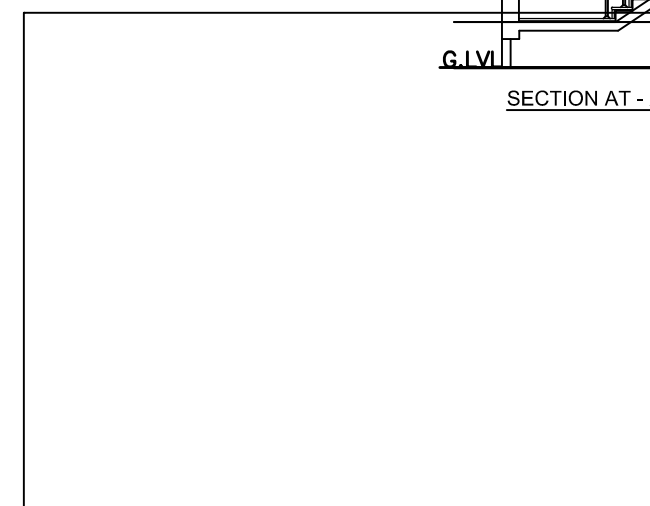
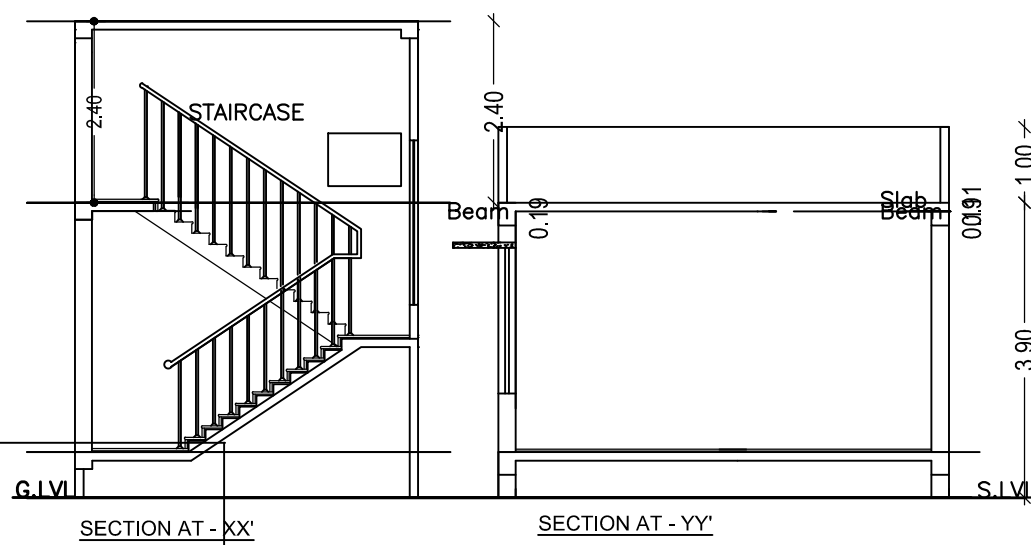
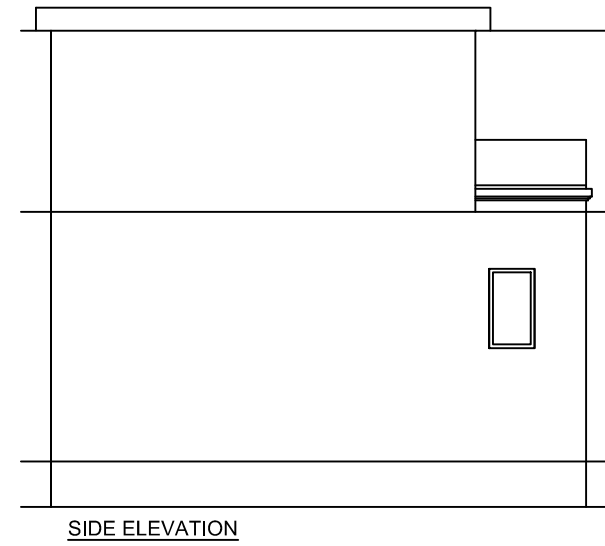
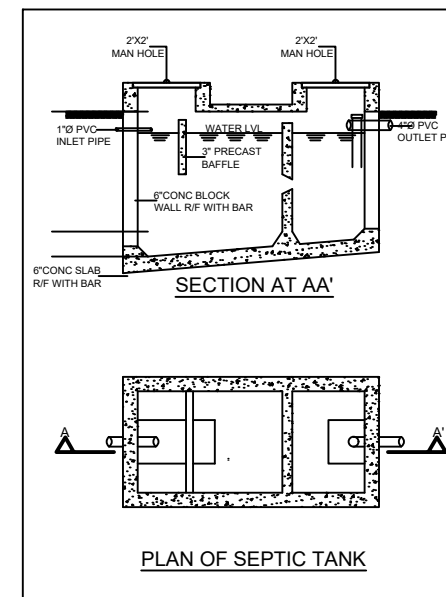
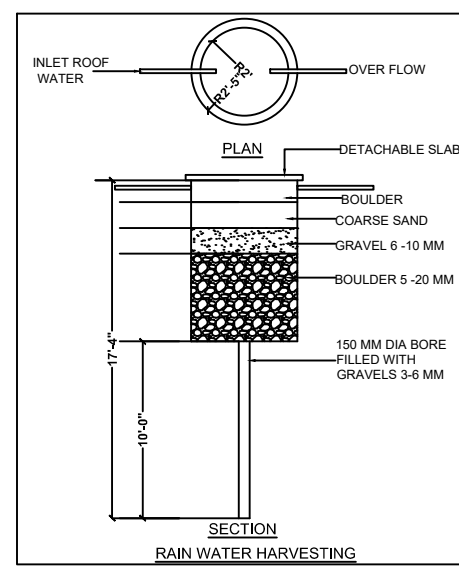
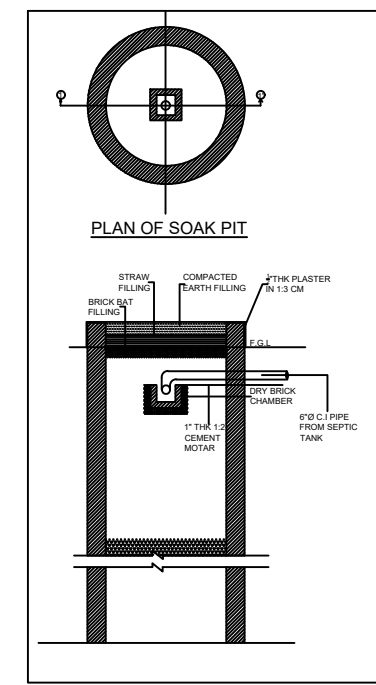
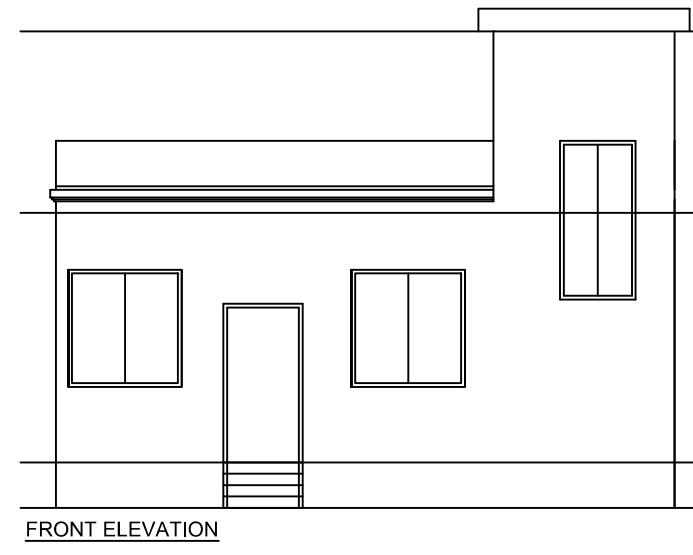
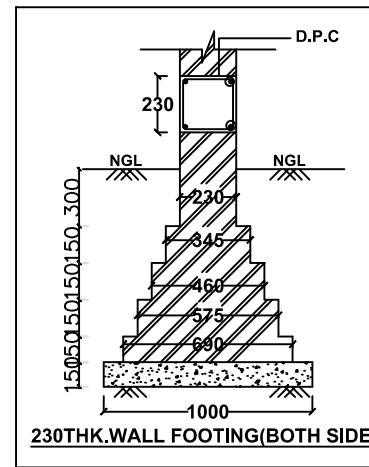
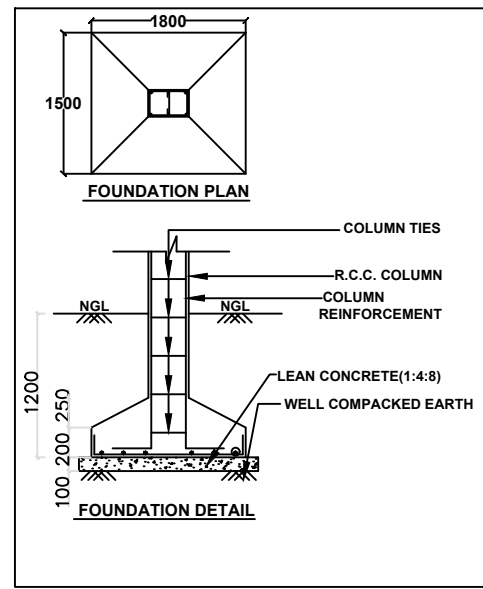

UnitBUA Table for Building :A (BUILDING)

FLOOR	Name	UnitBUA Type	UnitBUA Area	Carpel Area	No. of Rooms	No. of Tenement
GROUND FLOOR	FLAT		54.61	46.42	5	1
Total:	-	-	54.61	46.42	5	1

SCHEDULE OF DOOR:

BUILDING NAME	NAME	LENGTH	HEIGHT	NOS
A (BUILDING)	D2	0.75	2.10	01
A (BUILDING)	D1	1.00	2.10	04
A (BUILDING)	D	1.05	2.10	01

SCHEDULE OF WINDOW/VENTILATION:

BUILDING NAME	NAME	LENGTH	HEIGHT	NOS
A (BUILDING)	V1	0.60	1.20	01
A (BUILDING)	W1	1.50	1.20	03

FAR & Tenement Details (Table 4c-1)

Building	No. of Same Bldg	Total Built Up Area (Sq.mt.)	Proposed FAR Area (Sq.mt.) Resi.	Total FAR Area (Sq.mt.)	Total Consumed Additional FAR Area (Sq.mt.)	Tnmt (No.)
A (BUILDING)	1	54.61	54.61	54.61	54.61	01
Grand Total :	1	54.61	54.61	54.61	54.61	01

Building :A (BUILDING)

Floor Name	Total Built Up Area (Sq.mt.)	Proposed FAR Area (Sq.mt.) Resi.	Total FAR Area (Sq.mt.)	Total Consumed Additional FAR Area (Sq.mt.)	Tnmt (No.)
Ground Floor	54.61	54.61	54.61	54.61	01
Terrace Floor	0.00	0.00	0.00	0.00	00
Total :	54.61	54.61	54.61	54.61	01
Total Number of Same Buildings	1				
Total :	54.61	54.61	54.61	54.61	01

Building USE/SUBUSE Details

Building Name	Building Use	Building SubUse	Building Structure
A (BUILDING)	Residential	Bungalow/ Dwelling / Non Apartment	Non-Highrise

Buildingwise Floor FAR Details

Floor Name	Building Name		Total	
	Proposed Built Up Area (Sq.mt.)	Proposed FAR Area (Sq.mt.)	Total Proposed Built Up Area (Sq.mt.)	Total FAR Area (Sq.mt.)
Ground Floor	54.61	54.61	54.61	54.61
Terrace Floor	0.00	0.00	0.00	0.00
Total :	54.61	54.61	54.61	54.61

COLOR INDEX

PLOT BOUNDARY	Black
ABUTTING ROAD	Red
PROPOSED CONSTRUCTION	Green
COMMON PLOT	Yellow
ROAD WIDENING AREA	Blue
EXISTING (To be retained)	Orange
EXISTING (To be demolished)	Light Blue

AREA STATEMENT GARHWA NAGAR PARISHAD	VERSION NO.: 1.0.50
PROJECT DETAIL:	VERSION DATE: 16/10/2020
Region: JHARKHAND URBAN LOCAL BODIES	Plot Use: Residential
District: GARHWA	Plot SubUse: Bungalow/ Dwelling / Non Apartment
Authority: GARHWA NAGAR PARISHAD	Plot/Nearby/Religious/Structure: NA
Inward No: GNPC/BP/0029/W13/2020	Plot/SubPlot No: 544
Application Type: General Proposal	North: Plot No. - SURVEY ROAD
Project Type: Building Permission	South: Plot No. - SANDHYA DEVI
Nature of Development: New	East: Plot No. - APARNA MISHRA
Location of Development Area: Old Area	West: Road Width - 3.05
AREA DETAILS:	SQ.MT.
AREA OF PLOT (Minimum)	(A) 97.34
Deduction for NetPlot Area	
Surrender Free of Cost	4.60
Total	4.60
NET AREA OF PLOT (Gross Plot Area - Deduction from Gross Plot area)	(A-Deductions) 92.74
Deduction for Balance Plot Area (from Gross Plot Area)	
Surrender Free of Cost	4.60
Common Plot	16.32
Total	20.92
BALANCE AREA OF PLOT (Net Plot Area - Recreational/Amenity space)	(A-Deductions) 76.42
PLOT AREA FOR COVERAGE (Net Plot Area)	(A-Deductions) 92.74
Plot Area for FAR (Net Plot Area + Road Widening Area)	(A-Deductions) 97.34
COVERAGE CHECK	
Permissible Coverage area ( 70.00 % )	64.92
Proposed Coverage Area ( 58.89 % )	54.61
Total Prop. Coverage Area ( 58.89 % )	54.61
Balance coverage area ( 11.12 % )	10.31
FAR CHECK	
Perm. FAR Area ( 1.20 )	116.81
Total Perm. FAR area	116.81
Residential FAR	54.61
Proposed FAR Area	54.61
Total Proposed FAR Area	54.61
Consumed FAR (Factor)	0.56
Balance FAR Area	62.20
BUILT UP AREA CHECK	
Total Proposed BuiltUp Area	54.61
ARCHITECT (Regd)	KUMARI MEENAKSHI TIWARI
ENGINEER (Regd)	
SUPERVISOR (Regd)	
OWNER (Regd)	SHRI VIKASH KUMAR TIWARY
DEVELOPMENT AUTHORITY	LOCAL BODY

LTP NAME AND SIGNATURE	STRUCTURAL ENG'S NAME AND SIGNATURE	BUILDER NAME AND SIGNATURE	DIGITAL SIGNATURE
KUMARI MEENAKSHI TIWARI GNPC/ENG/0006/2019			