

Proposal Basic Information

Proposal File No.	GNPC/BP/0006/W12/2021
Owner Name	SHRI BRAJKISHOR PANDEY
Khata No	13
Plot No	72
Village Name	Pipra Kala
Use	Residential
SubUse	Bungalow/ Dwelling / Non Apartment

FAR & Tenement Details (Table 4c-1)

Building	No. of Same Bldg	Total Built Up Area (Sq.mt.)	Proposed FAR Area (Sq.mt.)	Total FAR Area (Sq.mt.)	Total Consumed Additional FAR Area (Sq.mt.)	Tnmt (No.)
A (BUILDING)	1	92.40	92.40	92.40	92.40	01
Grand Total :	1	92.40	92.40	92.40	92.40	01

Building USE/SUBUSE Details

Building Name	Building Use	Building SubUse	Building Structure
A (BUILDING)	Residential	Bungalow/ Dwelling / Non Apartment	Non-Highrise

Buildingwise Floor FAR Details

Floor Name	Building Name A (BUILDING)		Total	
	Proposed Built Up Area (Sq.mt.)	Proposed FAR Area (Sq.mt.)	Total Proposed Built Up Area (Sq.mt.)	Total FAR Area (Sq.mt.)
Ground Floor	92.40	92.40	92.40	92.40
Terrace Floor	0.00	0.00	0.00	0.00
Total :	92.40	92.40	92.40	92.40

COLOR INDEX

PLOT BOUNDARY	Black
ABUTTING ROAD	Green
PROPOSED CONSTRUCTION	Red
COMMON PLOT	Yellow
ROAD WIDENING AREA	Blue
EXISTING (To be retained)	Orange
EXISTING (To be demolished)	Light Blue

AREA STATEMENT GARHWA NAGAR PARISHAD

VERSION NO.:	1.0.53
VERSION DATE:	16/10/2020
PROJECT DETAIL:	
Region: JHARKHAND URBAN LOCAL BODIES	Plot Use: Residential
District: GARHWA	Plot SubUse: Bungalow/ Dwelling / Non Apartment
Authority: GARHWA NAGAR PARISHAD	PlotNearby/Religious/Structure: NA
Inward No: GNPC/BP/0006/W12/2021	Plot/SubPlot No: 72
Application Type: General Proposal	North: Road Width - 3.05
Project Type: Building Permission	South: Plot No. - 72
Nature of Development: New	East: Plot No. - 72
Location of Development Area: Old Area	West: Plot No. - 72

AREA DETAILS:

AREA OF PLOT (Minimum)	(A)	SQ.MT.
Deduction for NetPlot Area		150.00
Surrender Free of Cost		4.50
Total		4.50
NET AREA OF PLOT(Gross Plot Area - Deduction from Gross Plot area)	(A-Deductions)	145.50
Deduction for Balance Plot Area(from Gross Plot Area)		4.50
Surrender Free of Cost		21.21
Common Plot		25.71
Total		124.29
BALANCE AREA OF PLOT(Net Plot Area - Recreational/Amenity space)	(A-Deductions)	145.50
PLOT AREA FOR COVERAGE(Net Plot Area)	(A-Deductions)	150.00
Plot Area for FAR (Net Plot Area + RoadWidening Area)	(A-Deductions)	150.00

COVERAGE CHECK

Permissible Coverage area (70.00 %)	101.85
Proposed Coverage Area (63.51 %)	92.40
Total Prop. Coverage Area (63.51 %)	92.40
Balance coverage area (6.49 %)	9.45

FAR CHECK

Perm. FAR Area (1.20)	180.00
Total Perm. FAR area	180.00
Residential FAR	92.40
Proposed FAR Area	92.40
Total Proposed FAR Area	92.40
Consumed FAR (Factor)	0.62
Balance FAR Area	87.60

BUILT UP AREA CHECK

Total Proposed BuiltUp Area	92.40
ARCHITECT (Regd)	PRADEEP KUNTAL KUNTAL
ENGINEER (Regd)	
SUPERVISOR (Regd)	SHRI BRAJKISHOR PANDEY
OWNER (Regd)	
DEVELOPMENT AUTHORITY	LOCAL BODY

UnitBUA Table for Building :A (BUILDING)

FLOOR	Name	UnitBUA Type	UnitBUA Area	Carpet Area	No. of Rooms	No. of Tenement
GROUND FLOOR PLAN	FLAT	FLAT	92.40	79.92	8	1
Total:	-	-	92.40	79.92	8	1

SCHEDULE OF DOOR:

BUILDING NAME	NAME	LENGTH	HEIGHT	NOS
A (BUILDING)	D2	0.75	2.10	01
A (BUILDING)	D1	1.00	2.10	07
A (BUILDING)	D	1.05	2.10	01

SCHEDULE OF WINDOW/VENTILATION:

BUILDING NAME	NAME	LENGTH	HEIGHT	NOS
A (BUILDING)	V1	0.60	1.20	01
A (BUILDING)	W1	1.80	1.20	04

Building :A (BUILDING)

Floor Name	Total Built Up Area (Sq.mt.)	Proposed FAR Area (Sq.mt.)	Total FAR Area (Sq.mt.)	Total Consumed Additional FAR Area (Sq.mt.)	Tnmt (No.)
Ground Floor	92.40	92.40	92.40	92.40	01
Terrace Floor	0.00	0.00	0.00	0.00	00
Total :	92.40	92.40	92.40	92.40	01

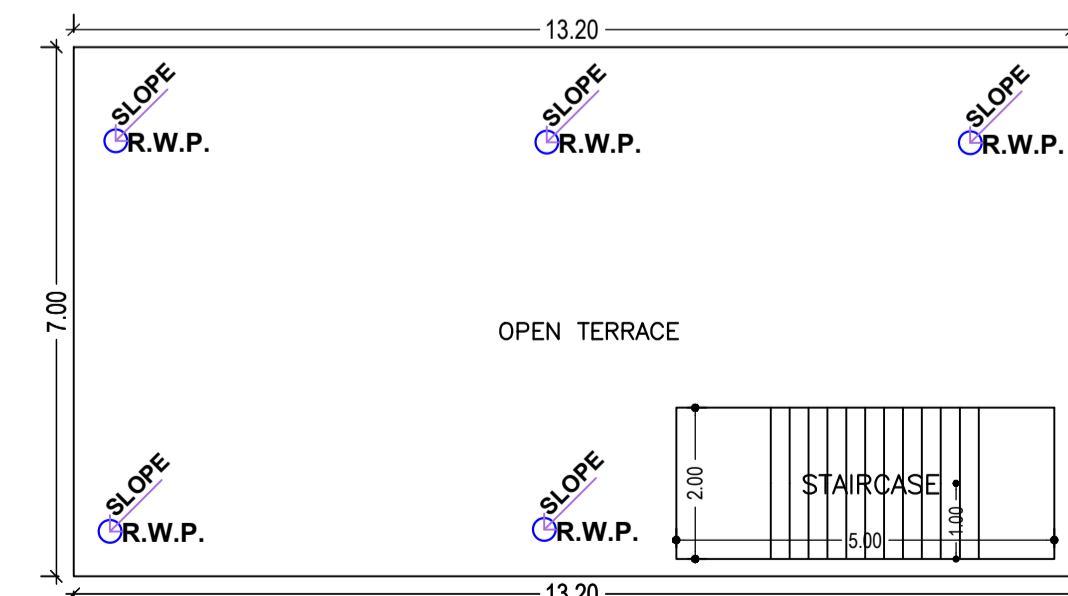
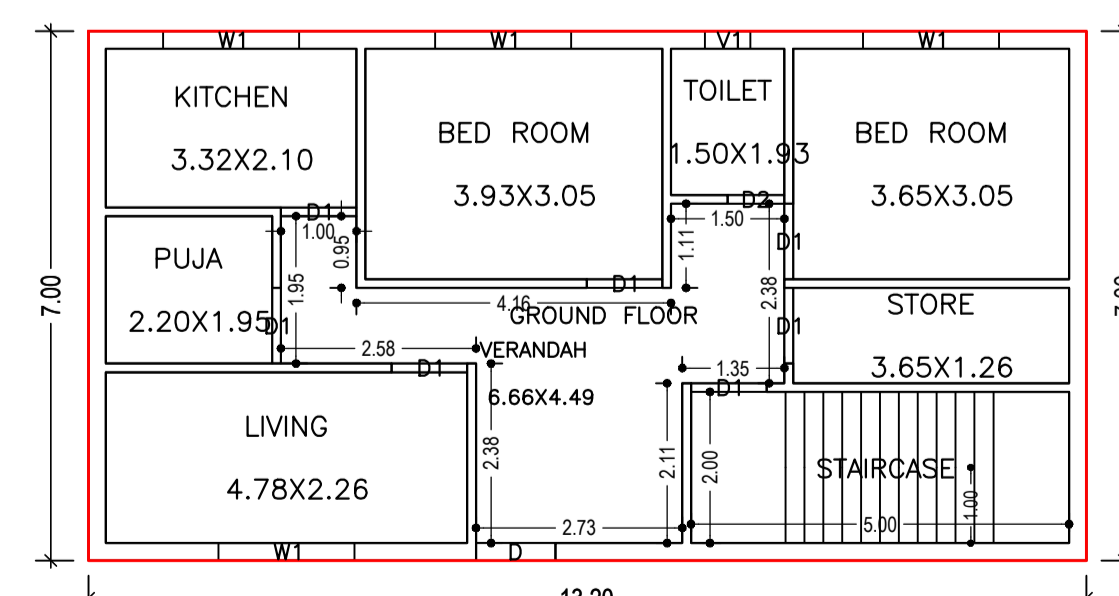
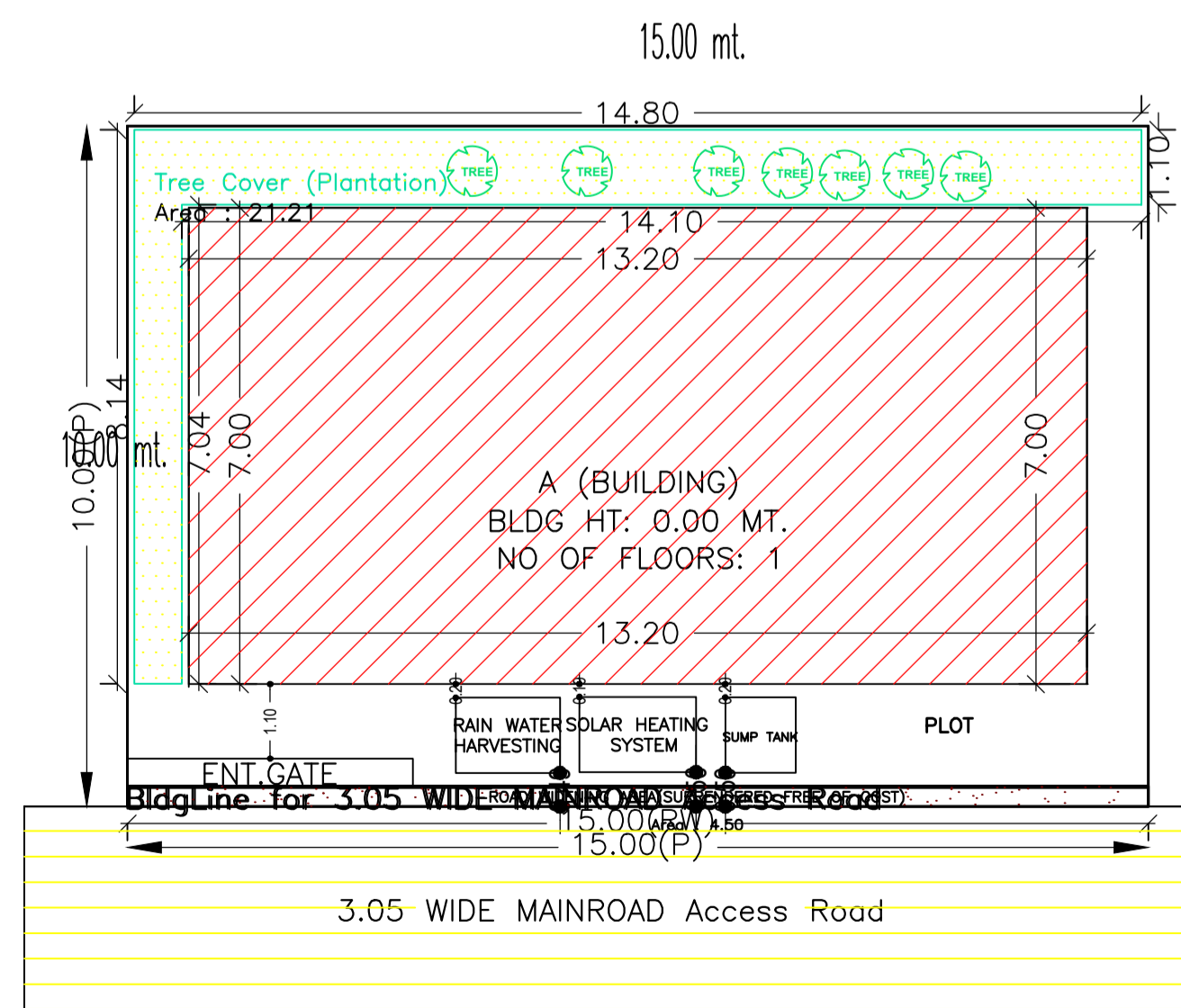
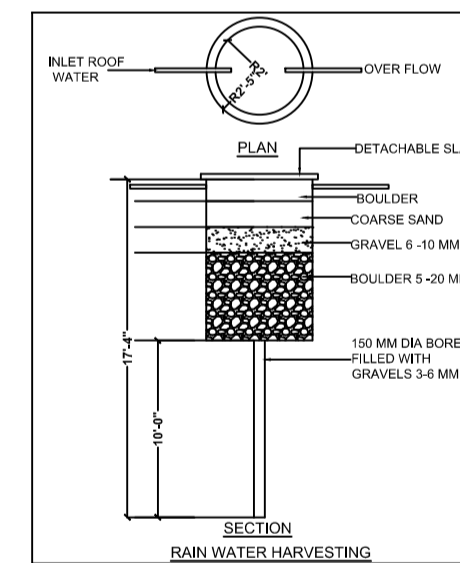
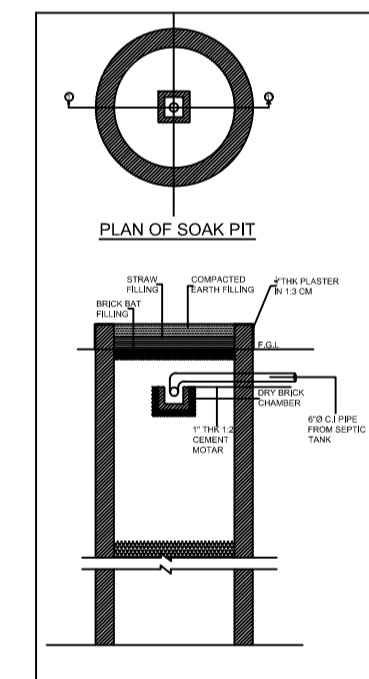
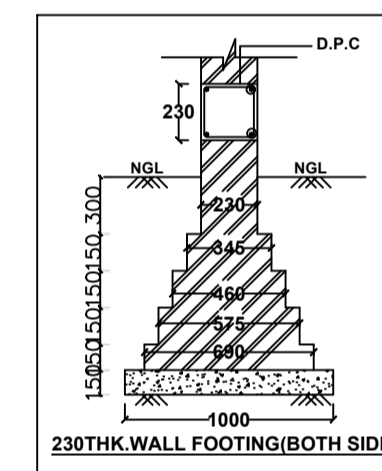
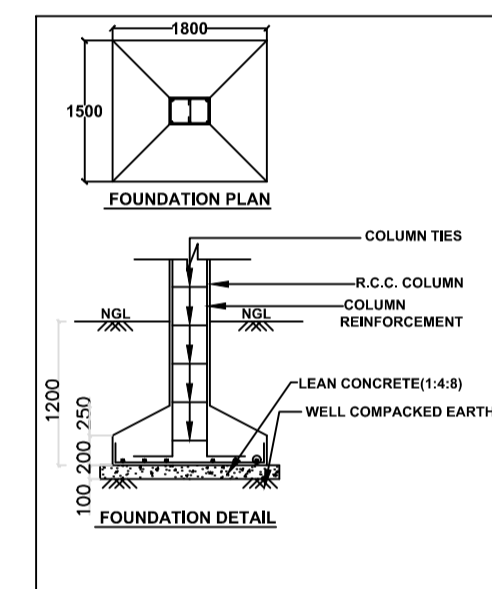
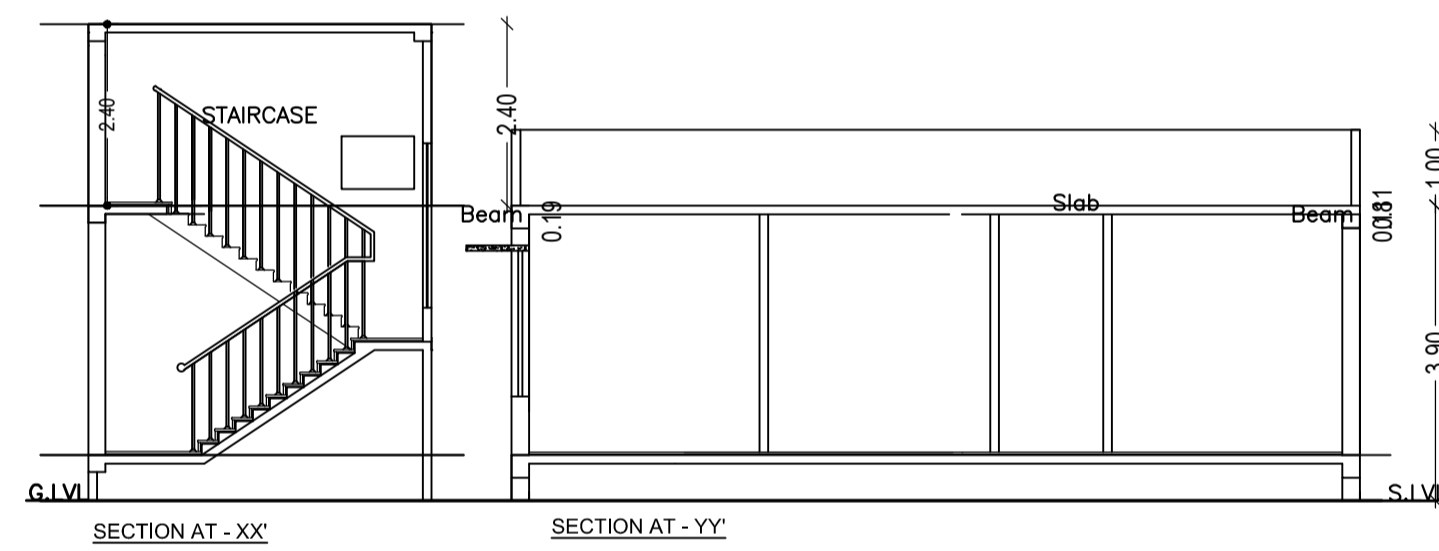
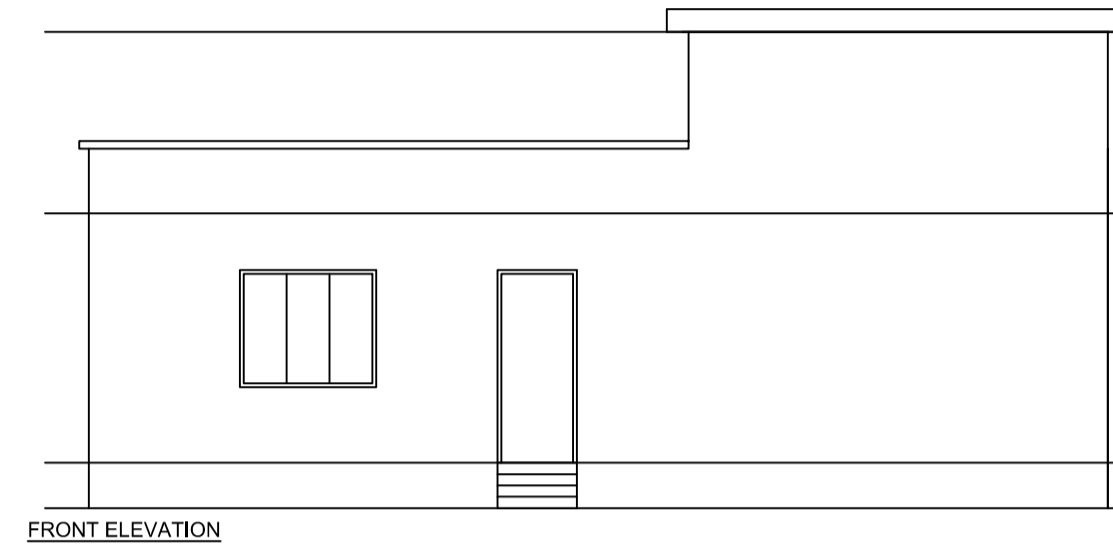
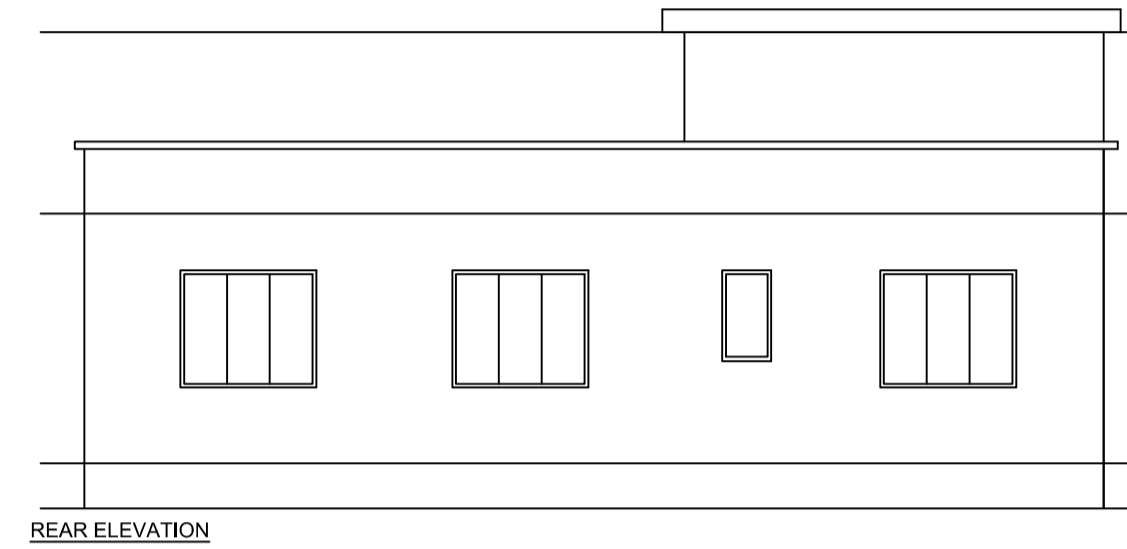
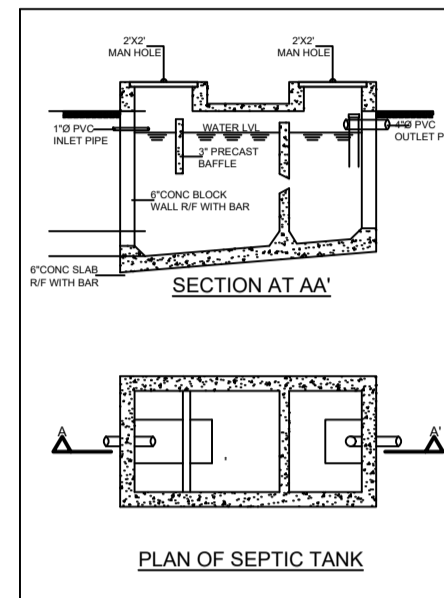

LTP NAME AND SIGNATURE	STRUCTURAL ENG'S NAME AND SIGNATURE	BUILDER NAME AND SIGNATURE	DIGITAL SIGNATURE
PRADEEP KUNTAL KUNTAL GNPC/ARC/0007/2017			