

Proposal Basic Information	
Proposal File No.	GNPC/ENG/0010/W11/2021
Owner Name	MANMATI DEVI
Khata No	162.10
Plot No	508.50/491
Village Name	Sahjani
Use	Residential
SubUse	Bungalow/ Dwelling / Non Apartment

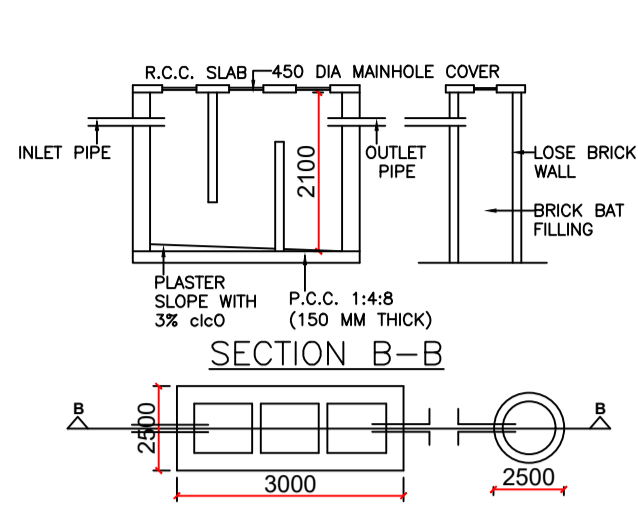

Septic Tank Detail

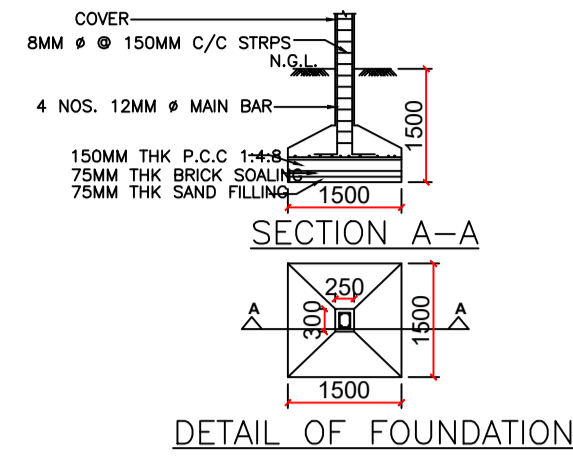

Structure Detail

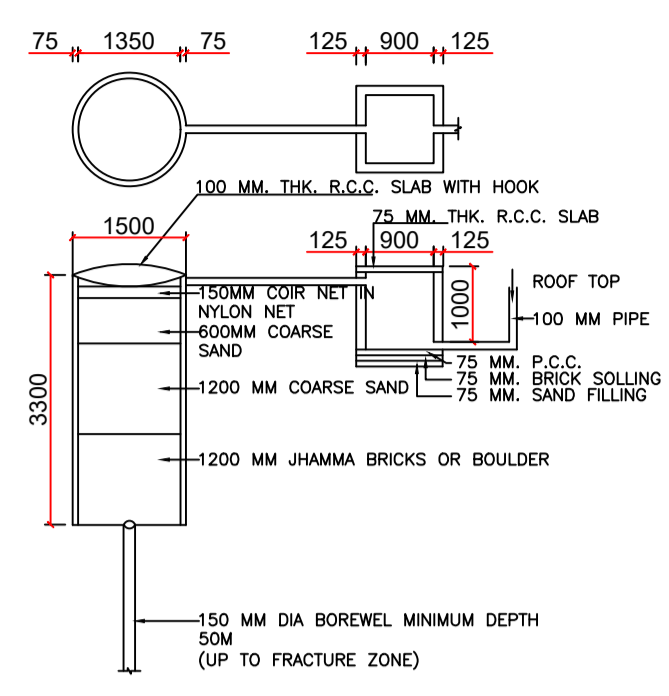

Rain Water Storage Tank Detail

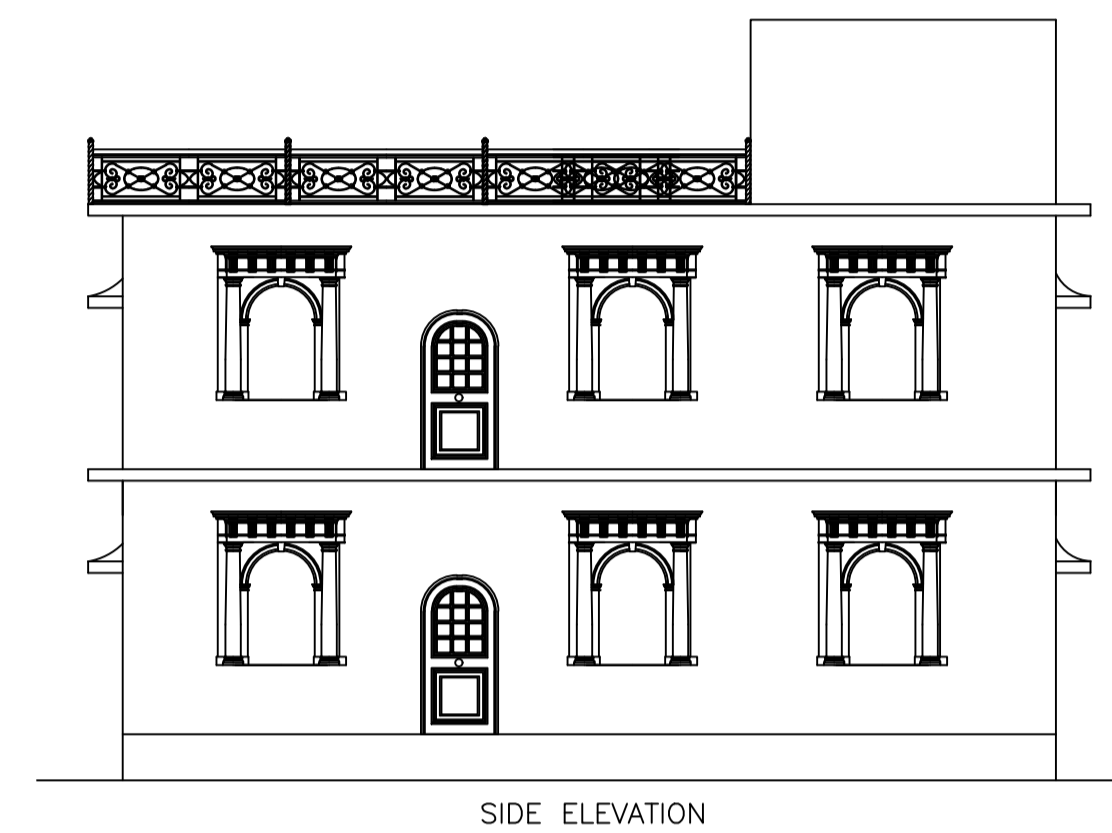
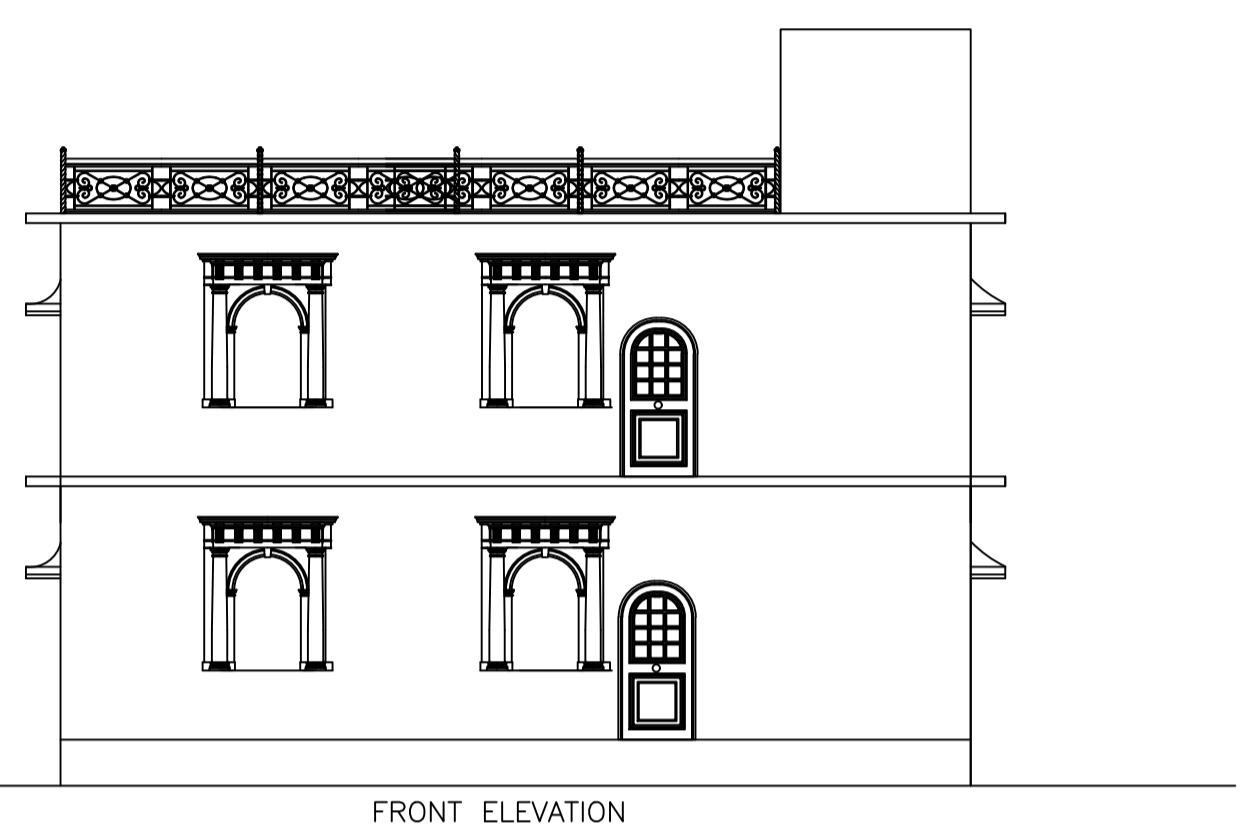
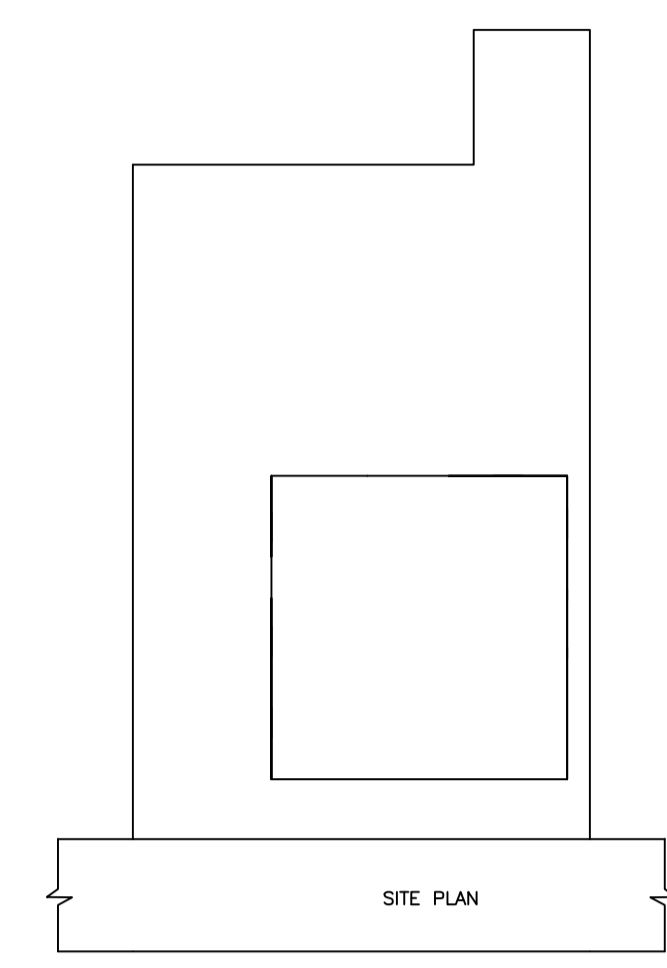

UnitBUA Table for Building :MANMATI (DEVI)

FLOOR	Name	UnitBUA Type	UnitBUA Area	Carpet Area	No. of Rooms	No. of Tenement
GROUND FLOOR PLAN	SPLIT A	FLAT	258.80	258.61	10	1
FIRST FLOOR PLAN	SPLIT A	FLAT	0.00	0.00	10	0
Total:	-	-	258.80	258.61	20	1

SCHEDULE OF DOOR:

BUILDING NAME	NAME	LENGTH	HEIGHT	NOS
MANMATI (DEVI)	D1	0.76	2.10	08
MANMATI (DEVI)	D	1.06	2.10	10
MANMATI (DEVI)	D3	1.22	2.10	02

SCHEDULE OF WINDOW/VENTILATION:

BUILDING NAME	NAME	LENGTH	HEIGHT	NOS
MANMATI (DEVI)	V	0.45	1.20	04
MANMATI (DEVI)	W	0.89	1.20	02
MANMATI (DEVI)	W	1.21	1.20	10
MANMATI (DEVI)	W1	1.56	1.20	02
MANMATI (DEVI)	W4	1.67	1.20	02

Building :MANMATI (DEVI)

Floor Name	Total Built Up Area (Sq.mt.)	Proposed FAR Area (Sq.mt.) Resi.	Total FAR Area (Sq.mt.)	Total Consumed Additional FAR Area (Sq.mt.)	Trmt (No.)
Ground Floor	148.62	148.62	148.62	148.62	01
First Floor	148.62	148.62	148.62	148.62	00
Terrace Floor	0.00	0.00	0.00	0.00	00
Total :	297.24	297.24	297.24	297.24	01
Total Number of Same Buildings	1				
Total :	297.24	297.24	297.24	297.24	01

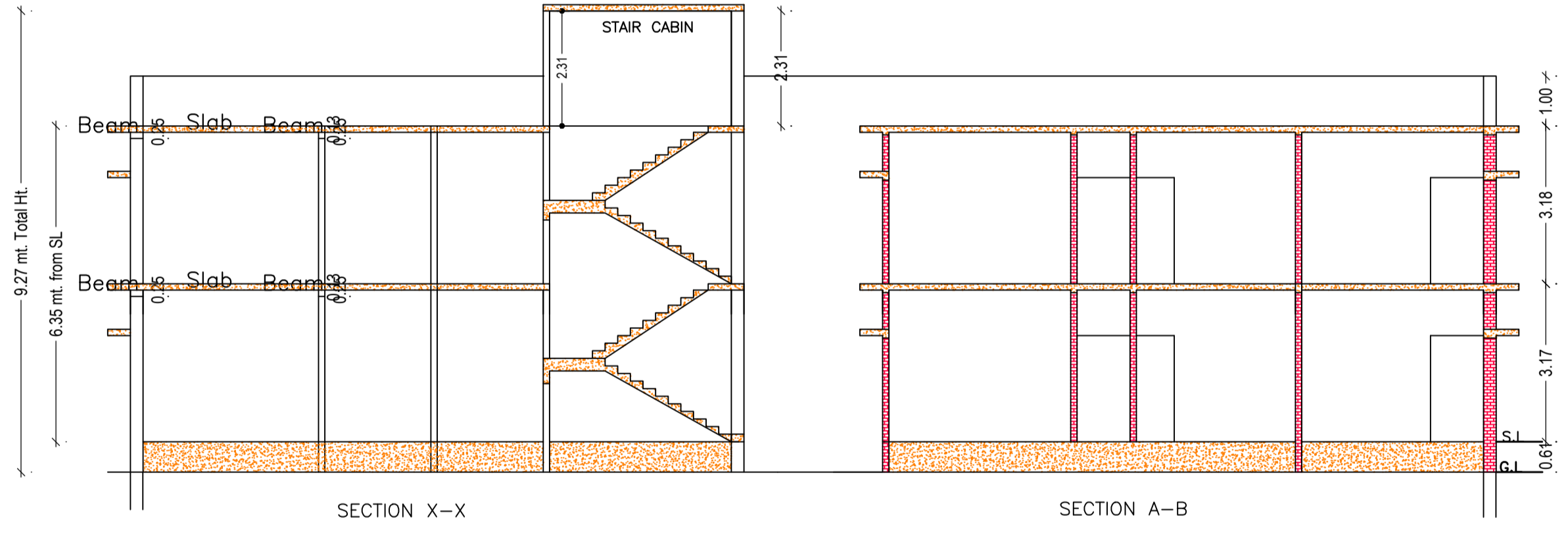

FAR & Tenement Details (Table 4c-1)

Building	No. of Same Bldg	Total Built Up Area (Sq.mt.)	Proposed FAR Area (Sq.mt.) Resi.	Total FAR Area (Sq.mt.)	Total Consumed Additional FAR Area (Sq.mt.)	Trmt (No.)
MANMATI (DEVI)	1	297.24	297.24	297.24	297.24	01
Grand Total :	1	297.24	297.24	297.24	297.24	01

Building USE/SUBUSE Details

Building Name	Building Use	Building SubUse	Building Structure
MANMATI (DEVI)	Residential	Bungalow/ Dwelling / Non Apartment	Non-Highrise

Buildingwise Floor FAR Details

Floor Name	Building Name (MANMATI (DEVI))		Total	
	Proposed Built Up Area (Sq.mt.)	Proposed FAR Area (Sq.mt.)	Total Proposed Built Up Area (Sq.mt.)	Total FAR Area (Sq.mt.)
Ground Floor	148.62	148.62	148.62	148.62
First Floor	148.62	148.62	148.62	148.62
Terrace Floor	0.00	0.00	0.00	0.00
Total :	297.24	297.24	297.24	297.24

COLOR INDEX

PLOT BOUNDARY	Black
ABUTTING ROAD	Green
PROPOSED CONSTRUCTION	Red
COMMON PLOT	Yellow
ROAD WIDENING AREA	Blue
EXISTING (To be retained)	Orange
EXISTING (To be demolished)	White

AREA STATEMENT GARHWA NAGAR PARISHAD		VERSION NO. : 1.0.54
PROJECT DETAIL:		VERSION DATE: 16/10/2020
Region : JHARKHAND URBAN LOCAL BODIES	Plot Use: Residential	
District: GARHWA	Plot SubUse: Bungalow/ Dwelling / Non Apartment	
Authority: GARHWA NAGAR PARISHAD	Plot/Nearby/Religious/Structure: NA	
Inward No: GNPC/ENG/0010/W11/2021	Plot/SubPlot No: 508.50/491	
Application Type: General Proposal	North: Road Width - 4.57	
Project Type: Building Permission	South: Plot No. - 509	
Nature of Development: New	East: Plot No. - 403,404	
Location of Development Area: New Area	West: Plot No. - 491	
AREA DETAILS:		
AREA OF PLOT (Minimum)	(A)	SQ.MT. 475.00
Deduction for NetPlot Area		
Surrender Free of Cost		14.13
Total		14.13
NET AREA OF PLOT(Gross Plot Area - Deduction from Gross Plot area)	(A-Deductions)	460.87
Deduction for Balance Plot Area(from Gross Plot Area)		
Surrender Free of Cost		14.13
Common Plot		62.56
Total		76.69
BALANCE AREA OF PLOT(Net Plot Area - Recreational/Amenity space)	(A-Deductions)	389.31
PLOT AREA FOR COVERAGE(Net Plot Area)	(A-Deductions)	460.87
Plot Area for FAR (Net Plot Area + Road Widening Area)	(A-Deductions)	475.00
COVERAGE CHECK		
Permissible Coverage area (60.00 %)		276.52
Proposed Coverage Area (32.25 %)		148.62
Total Prop. Coverage Area (32.25 %)		148.62
Balance coverage area (27.75 %)		127.90
FAR CHECK		
Perm. FAR Area (1.50)		712.50
Total Perm. FAR area		712.50
Residential FAR		297.24
Proposed FAR Area		297.24
Total Proposed FAR Area		297.24
Consumed FAR (Factor)		0.63
Balance FAR Area		415.26
BUILT UP AREA CHECK		
Total Proposed BuiltUp Area		297.24
ARCHITECT (Regd)	RAHUL KUMAR	
ENGINEER (Regd)		
SUPERVISOR (Regd)		
OWNER (Regd)	MANMATI DEVI	
DEVELOPMENT AUTHORITY		LOCAL BODY

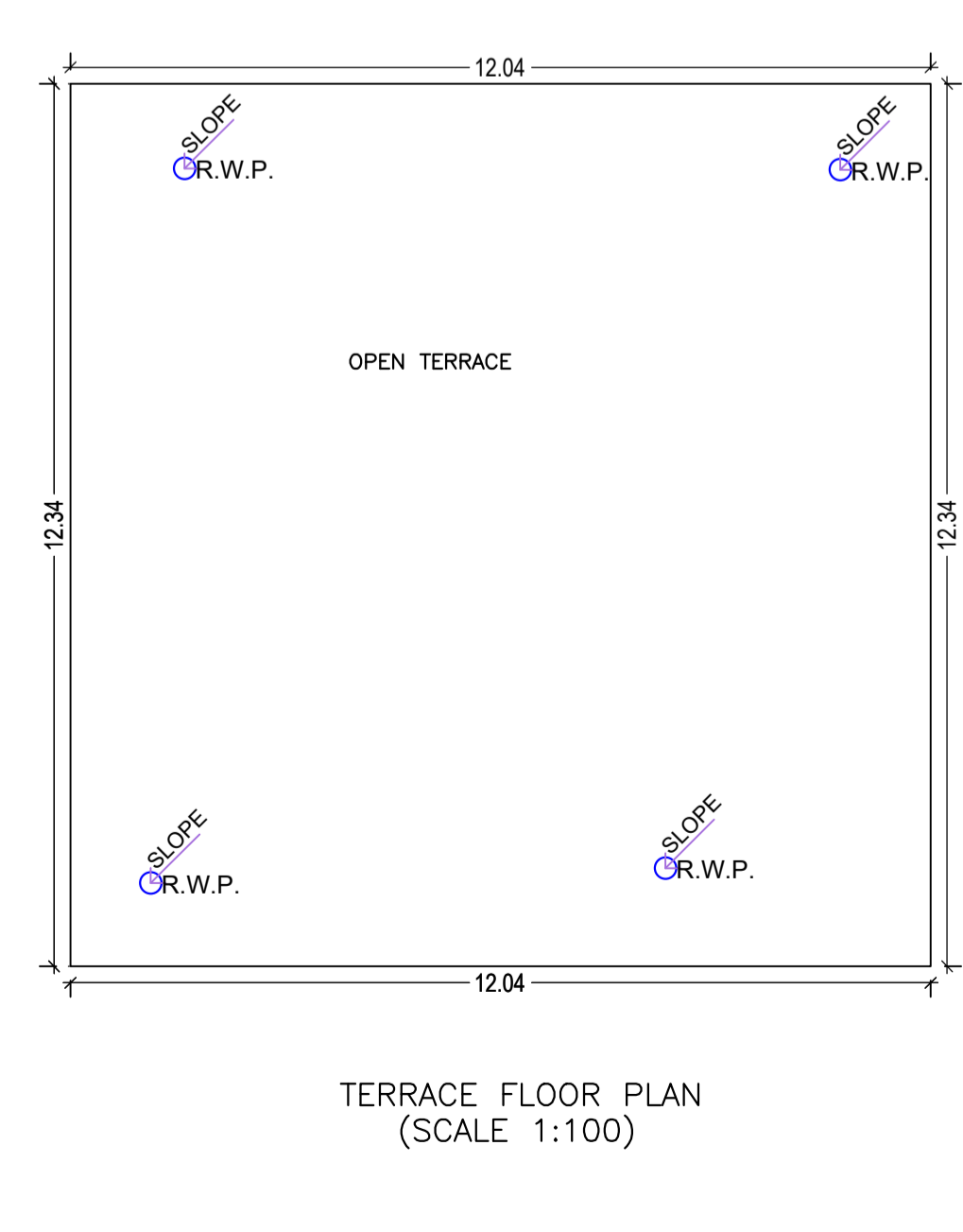
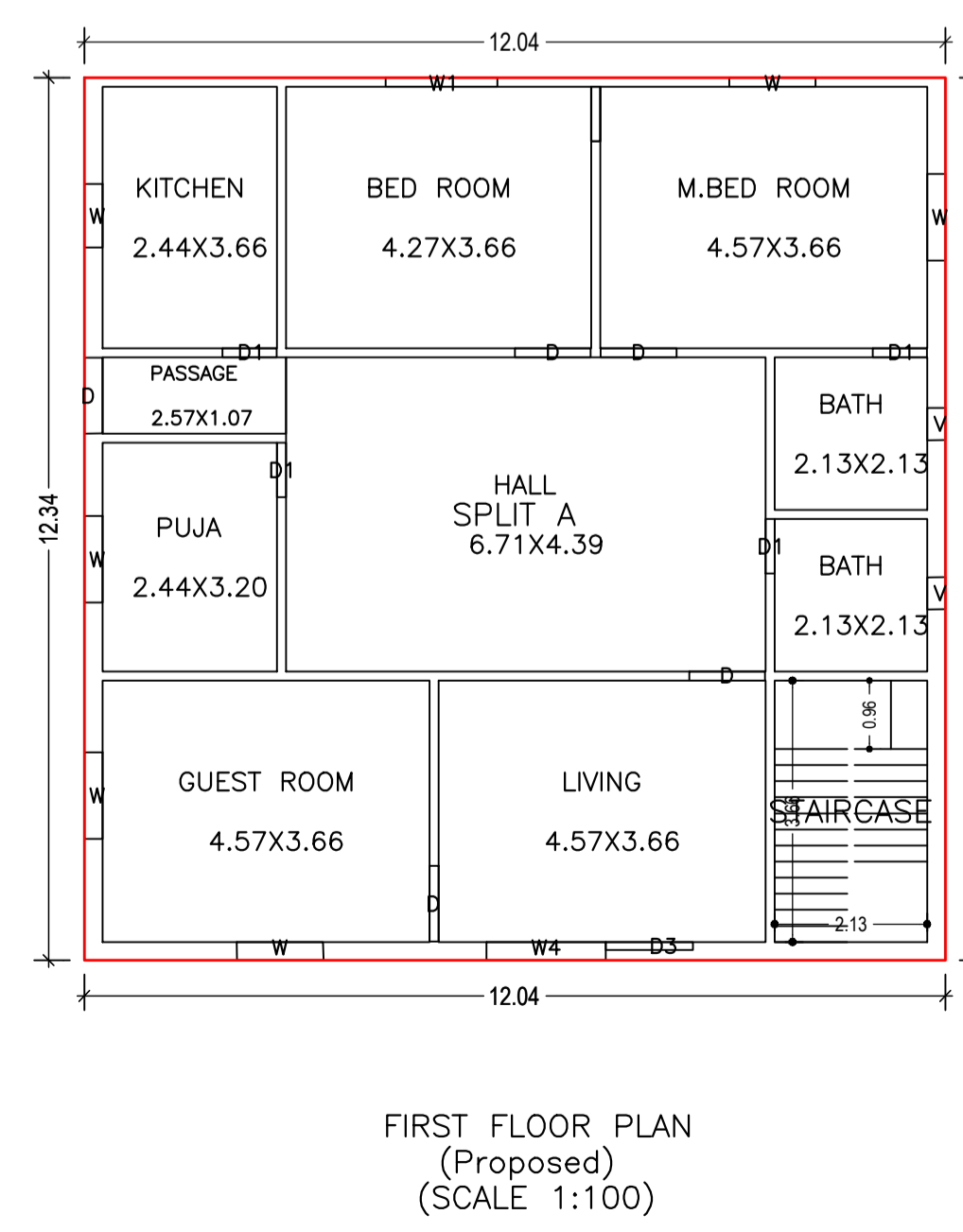
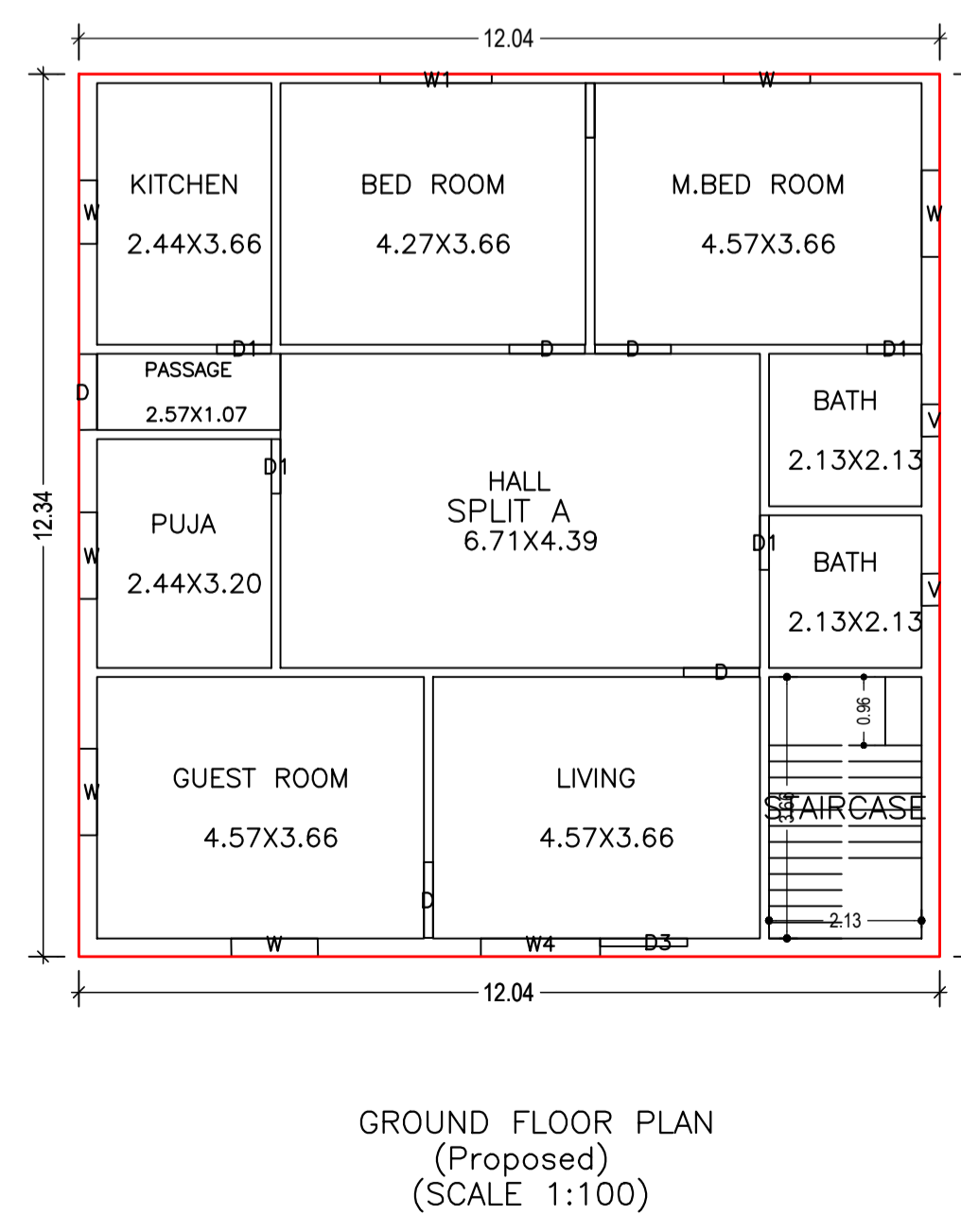
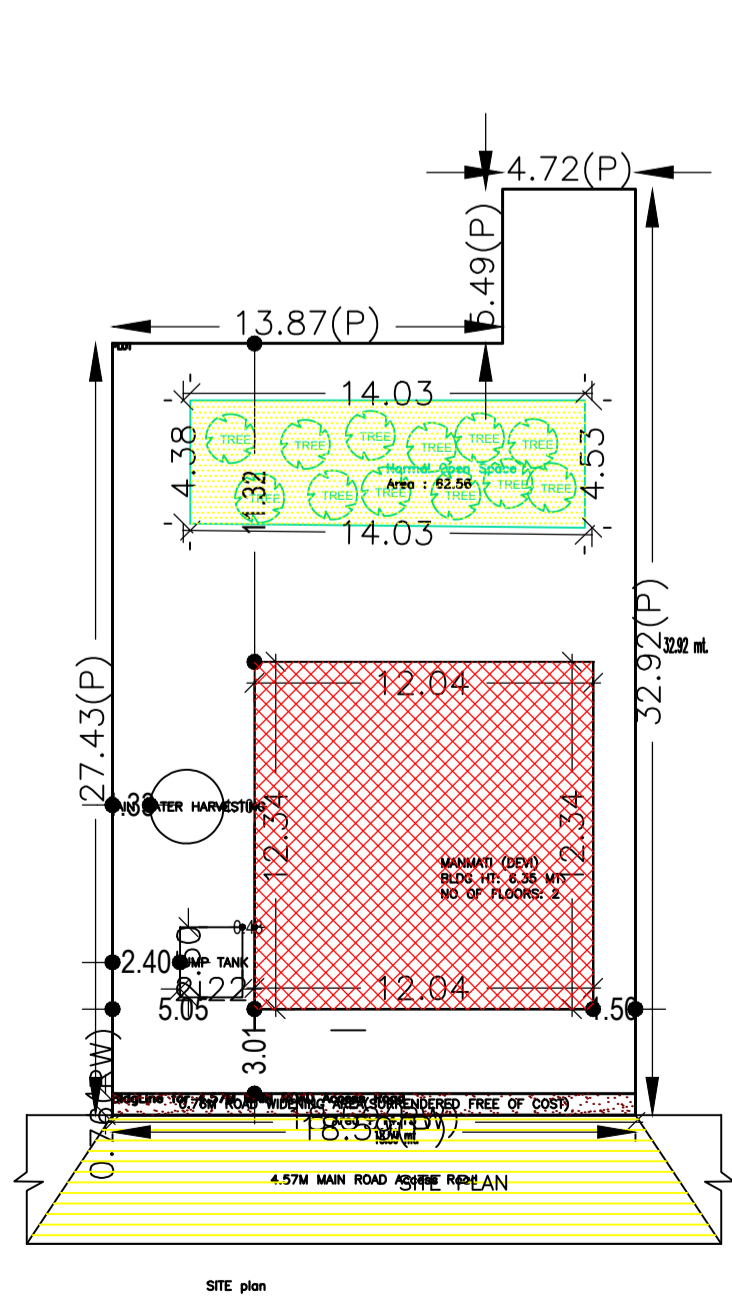

LTP NAME AND SIGNATURE	STRUCTURAL ENG'S NAME AND SIGNATURE	BUILDER NAME AND SIGNATURE	DIGITAL SIGNATURE
RAHUL KUMAR GNPC/ENG/003/2020			