

# Project Title : BRIJESH KUMAR UPADHAYAY

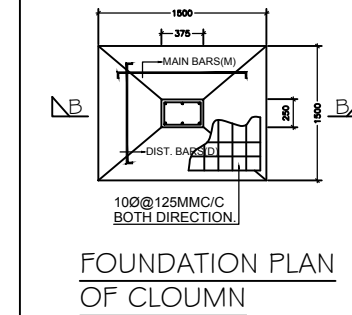
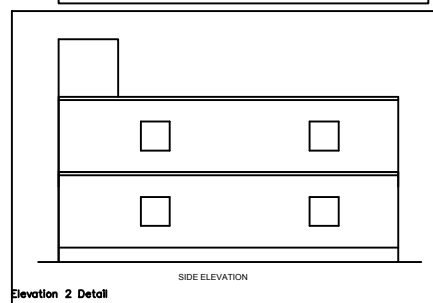
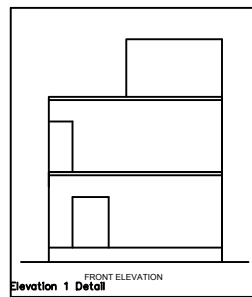
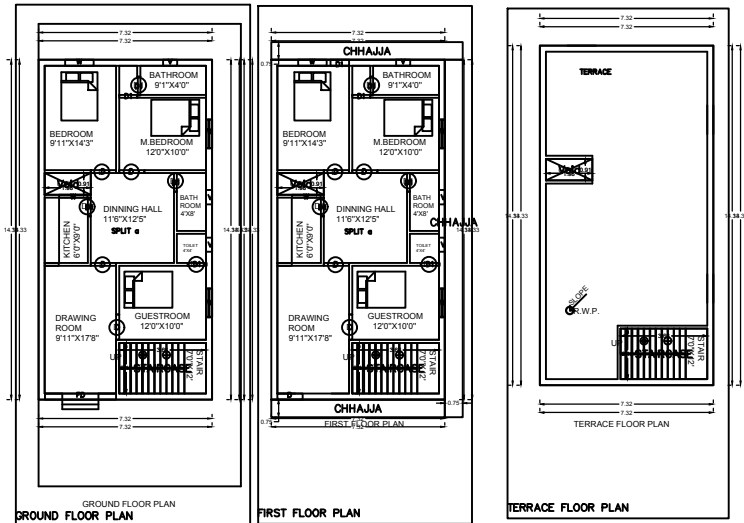
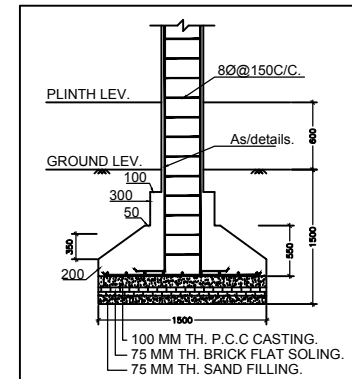
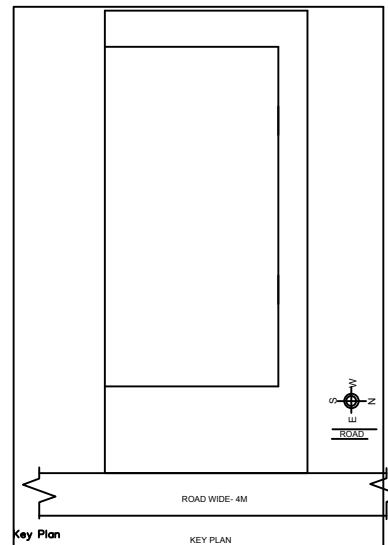
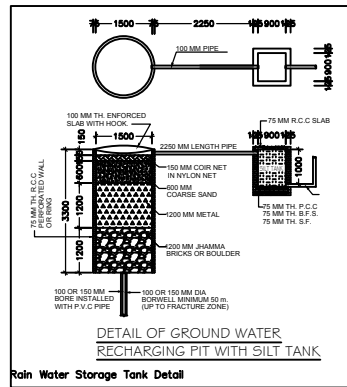
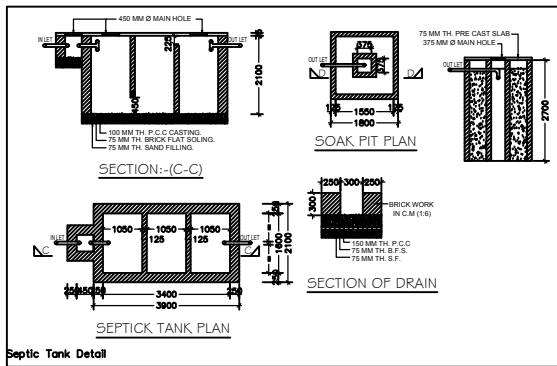

SIGN. WITH SEAL BY AUTH. AUTHORITY

SL.	SPECIFICATION
1.	Dimension : All dimensions are mentioned in feet & inches
2.	Excavation : As per required depth and width below the M.G.
3.	Foundation : As per design of Reinforced Cement Concrete/R.C.C.
4.	Concrete/R.C.C. : As per M - 10 Mix Grade with 2% thickness or noted
5.	D.P.C. : As per M - 15 Mix Grade with 2" thickness or noted
6.	Grade or other noted
7.	RCC : As per M - 20 or M - 25 Mix Grade or other noted
8.	Steel : As per design and FE - 415 of Electrodes/16mm dia.
9.	Brick Work : First Class Brick Work with Cement Mortar 1 : 6 Mix
10.	Plaster Work : External Plaster for Superstructure & e. t. - 6 Mix in Ceiling, Outer Walls & Inner Walls respectively
11.	Paint / White Wash / Snowcap in Outer side Wall and Colour Wash / Oil Bound Distemper in Inner side wall & Ceiling
12.	Wood Work : With Sal Wood / Teak Wood or Standed Wood

SL.	SCHEDULE OF OPENING	
1.	15.	
2.	16.	
3.	17.	
4.	18.	
5.	19.	
6.	20.	
7.	21.	
8.	22.	
9.	23.	
10.	24.	
11.	25.	
12.	26.	
13.	27.	
14.	28.	

SCHEDULE OF AREA			
BUILT UP IN 0th FLOOR	- SQFT	TOTAL PLOT AREA	- SQFT
BUILT UP IN 1st FLOOR	- SQFT	TOTAL PLOT AREA	- DECIMAL
BUILT UP IN 2nd FLOOR	- SQFT	FAR BY LAWS	-
BUILT UP IN 3rd FLOOR	- SQFT	FAR BY ACTUAL	-
BUILT UP IN 4th FLOOR	- SQFT	% OF COVERAGE	- PERCENT
BUILT UP IN 5th FLOOR	- SQFT	PERMITTED AREA	- SQFT
TOTAL BUILT UP AREA	- SQFT	DEVIATION AREA	- SQFT

MOUZA	PARGANA	THANA NO.	THANA	DISTRICT
SURVEY SHEET NO.	KHATA NO.	PLOT NO.	PLOT AREA SQFT.	OVERSHANG AREA DECIMAL.

DRWG. NO. 108	PLANNED BY: ER. RAHUL KUMAR
	CHECKED BY: MR.
	VERIFIED BY: MR.
APPROV. DATE	REVISION

OWNER	ARCHITECT/ENGINEER

PROPOSED RESIDENTIAL BUILDING FOR  
 BRIJESH KUMAR UPADHYAY S/O  
 GANDESHWAR UPADHYAY  
 KIRAN DEVI W/O CHANDRA SHEKHAR  
 UPADHYAY  
 LAND UNDER MOUZA :- SAHIJANA  
 GARHWA,  
 WARD NO :- 13, UNDER PLOT  
 NO-716 KHATA NO.-159,THANA  
 NO-345,  
 HOLDING NO-0130000517000M0  
 GARHWA,  
 DISTRICT :- GARHWA, JHARKHAND.

SCHEDULE OF DOORS & WINDOWS				
SL. NO.	TYPE	WIDTH	DEPTH	HEIGHT
1.	D	4-0"	0-0"	7-0"
2.	D1	3-0"	0-0"	7-0"
4.	D2	2-6"	0-0"	7-0"
5.	W	4-0"	3-0"	4-0"
6.	W1	5-0"	3-0"	4-0"
7.	V	1-6"	7-0"	2-0"

