

Proposal Basic Information	
Proposal File No.	GNPC/EN/0059/W01/2022
Owner Name	1) SAJID NAJAM KHAN 2) ADIL NAJAM KHAN
Khata No	62
Plot No	492
Village Name	Unchari
Use	Residential
SubUse	Bungalow/ Dwelling / Non Apartment

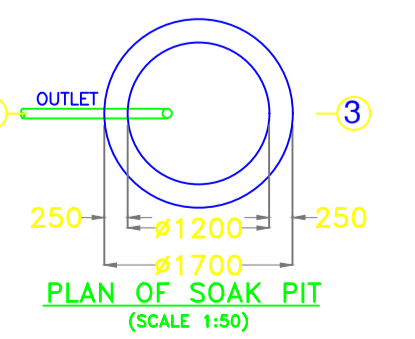
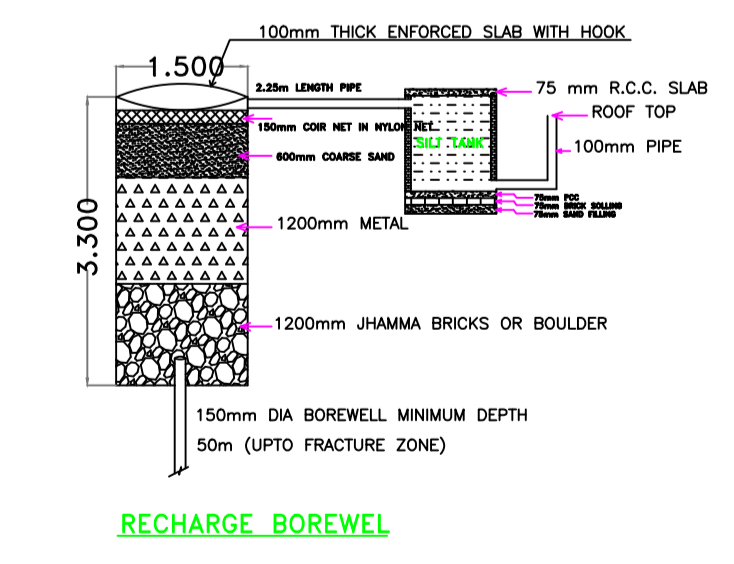
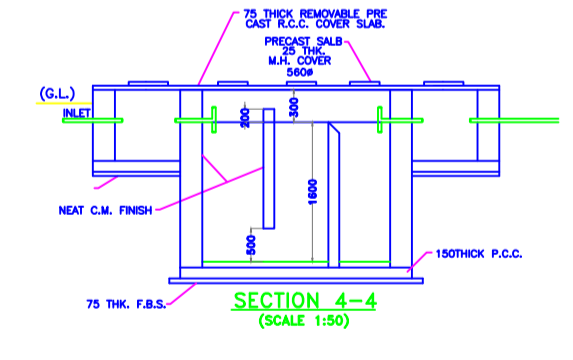
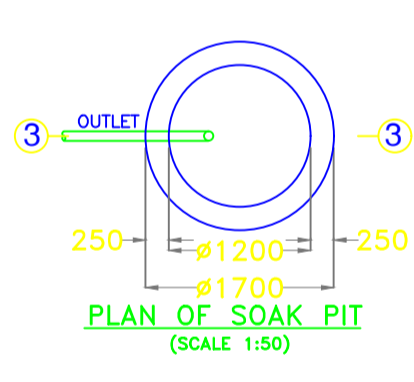
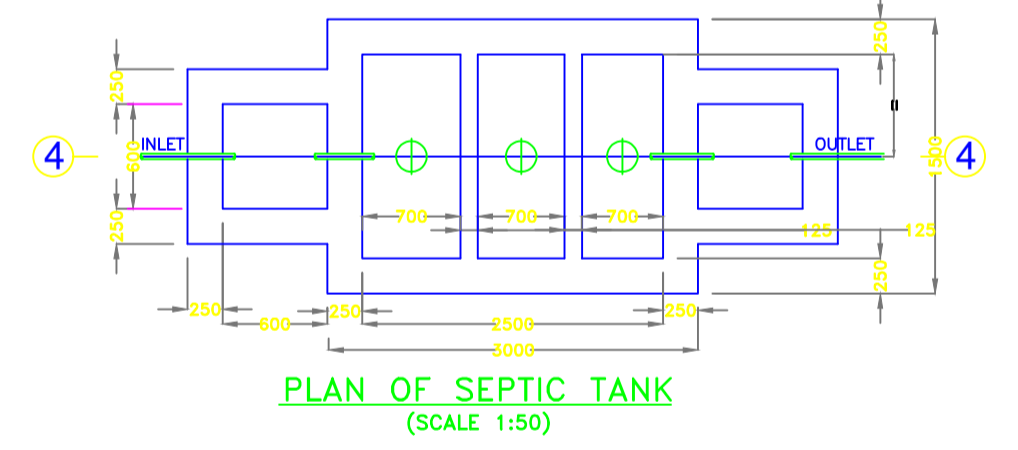
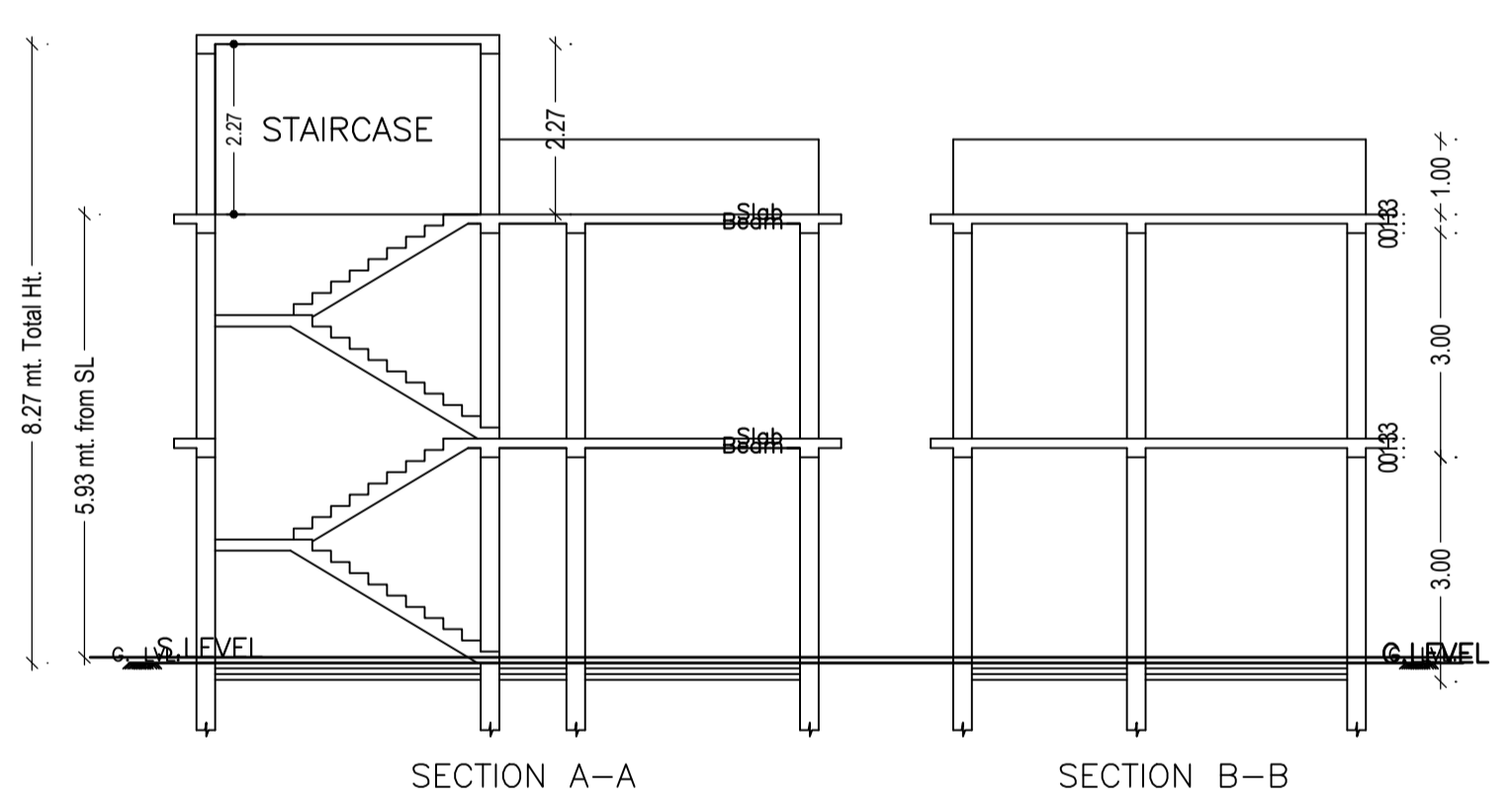
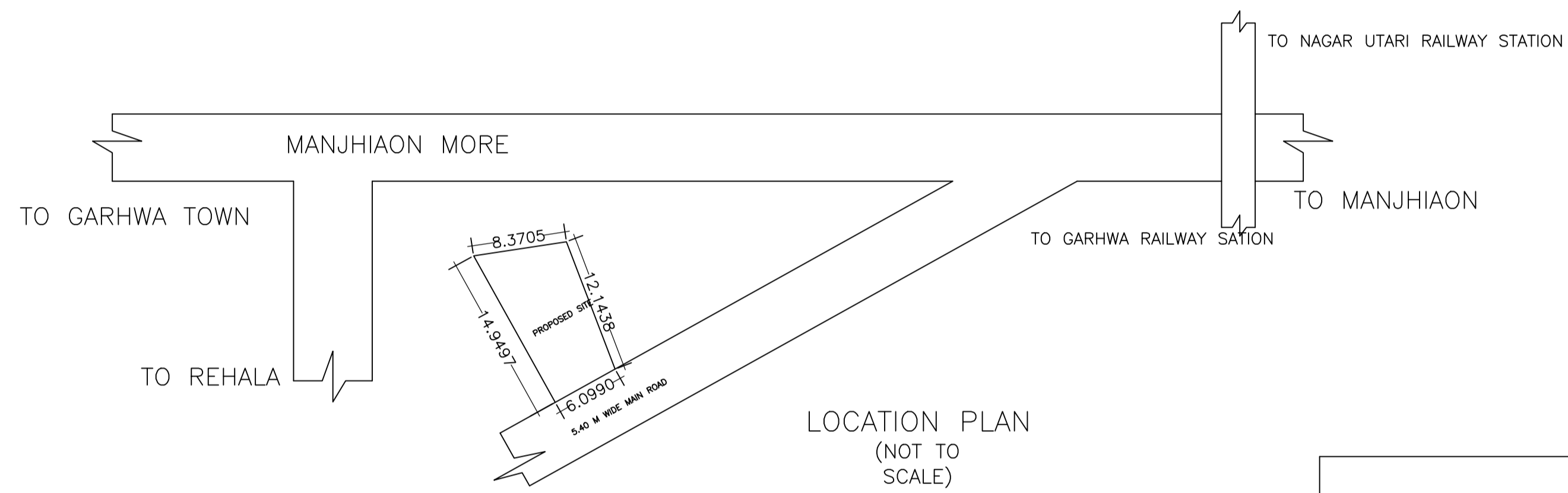
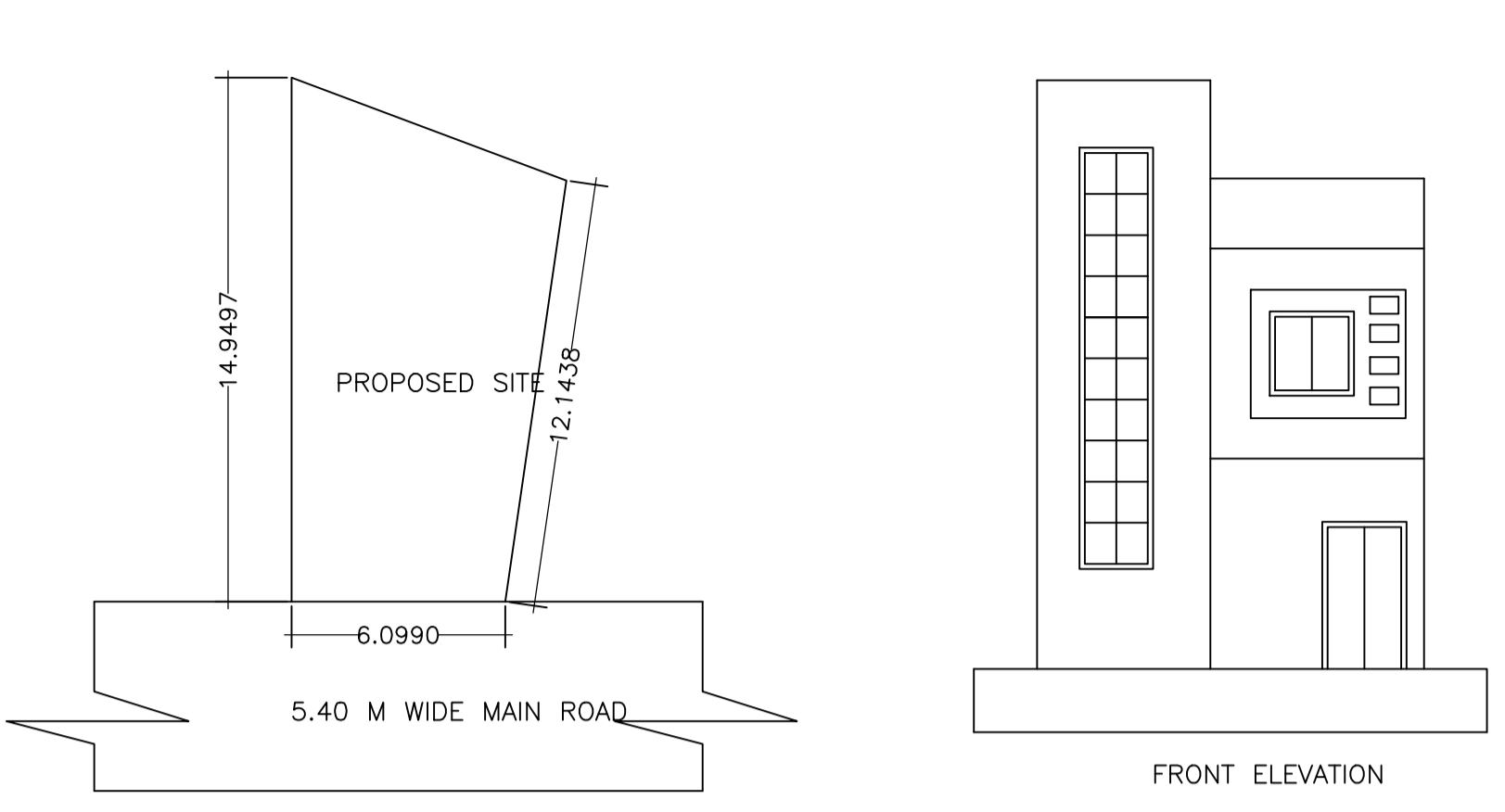
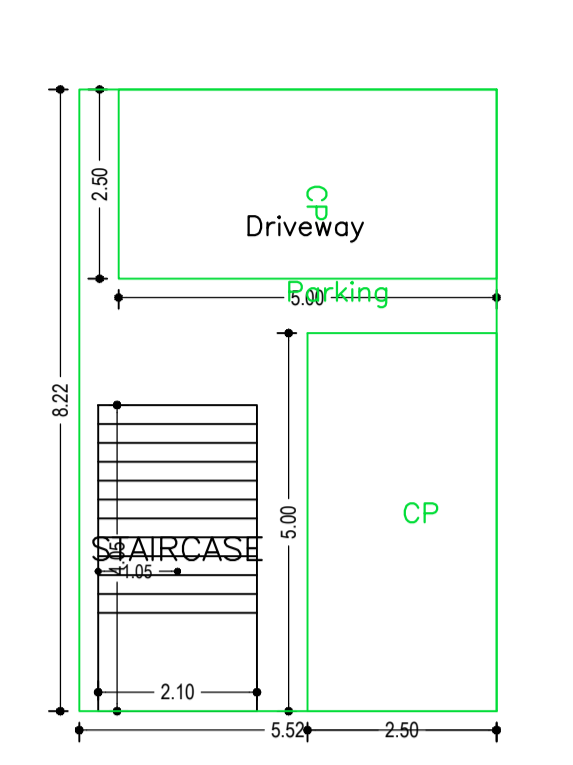
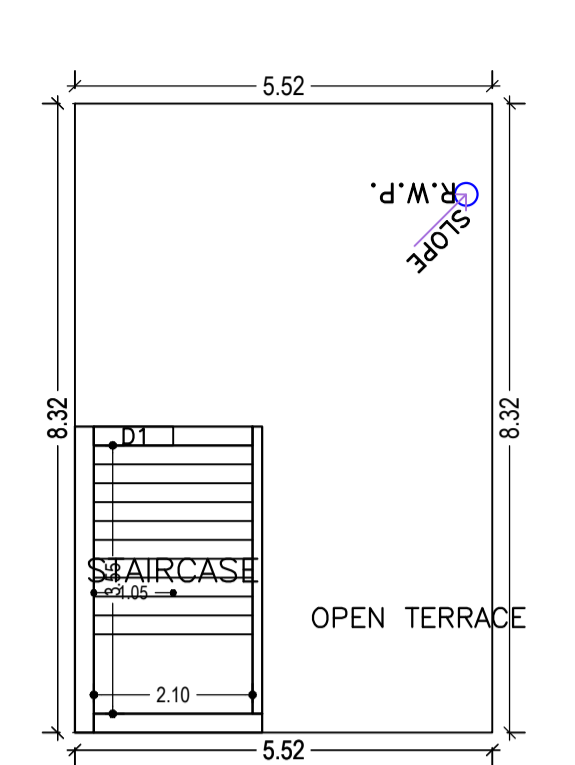
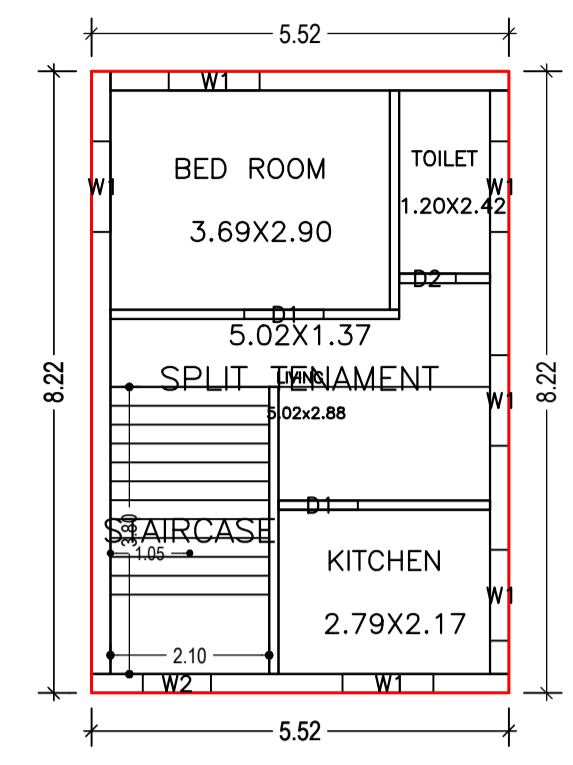
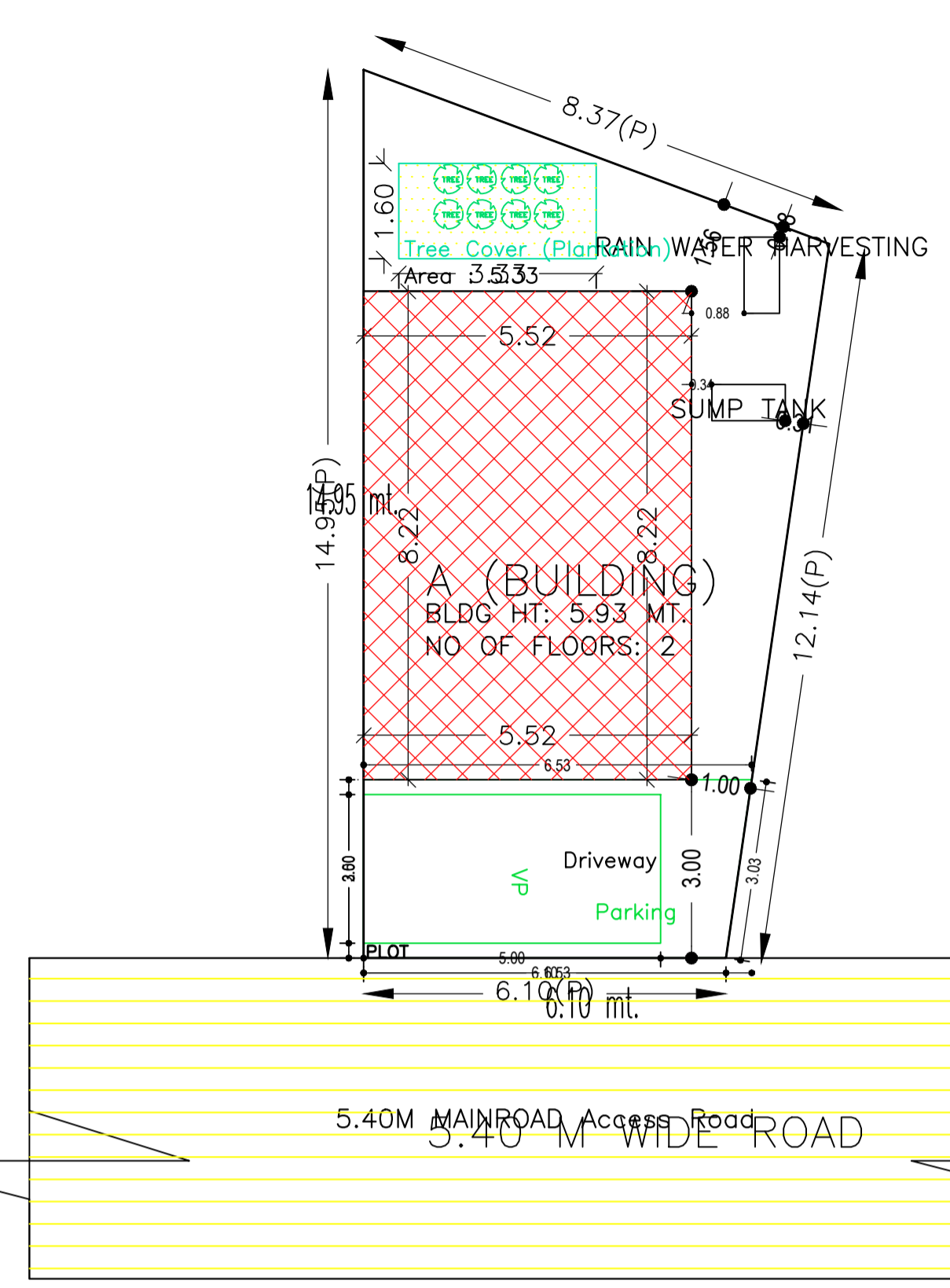

UnitBUA Table for Building :A (BUILDING)

FLOOR	Name	UnitBUA Type	UnitBUA Area	Carpet Area	No. of Rooms	No. of Tenement
FIRST FLOOR	SPLIT TENAMENT	FLAT	45.38	36.95	4	1
Total:	-	-	45.38	36.95	4	1

SCHEDULE OF DOOR:

BUILDING NAME	NAME	LENGTH	HEIGHT	NOS
A (BUILDING)	D2	0.75	2.10	01
A (BUILDING)	D1	1.05	2.10	02

SCHEDULE OF WINDOW/VENTILATION:

BUILDING NAME	NAME	LENGTH	HEIGHT	NOS
A (BUILDING)	W2	0.90	2.10	01
A (BUILDING)	W1	1.20	1.20	06

COLOR INDEX

Color	Description
Black	PLOT BOUNDARY
Green	ABUTTING ROAD
Red	PROPOSED CONSTRUCTION
Blue	COMMON PLOT
Yellow	ROAD WIDENING AREA
White	EXISTING (To be retained)
Grey	EXISTING (To be demolished)

LTP NAME AND SIGNATURE	STRUCTURAL ENG'S NAME AND SIGNATURE	BUILDER NAME AND SIGNATURE	DIGITAL SIGNATURE
RESHAN ALI GNPC/ENG/0059/2017			

AREA STATEMENT GARHWA NAGAR PARISHAD		VERSION NO.:	1.0.64
PROJECT DETAIL:		VERSION DATE: 16/10/2020	
Region: JHARKHAND URBAN LOCAL BODIES	Plot Use: Residential		
District: GARHWA	Plot SubUse: Bungalow/ Dwelling / Non Apartment		
Authority: GARHWA NAGAR PARISHAD	PlotNearby/ReligiousStructure: NA		
Inward No: GNPC/BP/0059/W01/2022	Plot/SubPlot No: 492		
Application Type: General Proposal	North: Road Width - 5.40		
Project Type: Building Permission	South: Plot No. - 492		
Nature of Development: New	East: Plot No. - 492		
Location of Development Area: Old Area	West: Plot No. - 492		
AREA DETAILS:			SQ.MT.
AREA OF PLOT (Minimum)	(A)		95.26
NET AREA OF PLOT(Gross Plot Area - Deduction from Gross Plot area)	(A-Deductions)		95.26
Deduction for Balance Plot Area(from Gross Plot Area)			
Common Plot			5.33
Total			5.33
BALANCE AREA OF PLOT(Net Plot Area - Recreational/Amenity space)	(A-Deductions)		89.92
PLOT AREA FOR COVERAGE(Net Plot Area)	(A-Deductions)		95.26
Plot Area for FAR (Net Plot Area + Road/Widening Area)	(A-Deductions)		95.26
COVERAGE CHECK			
Permissible Coverage area (70.00 %)			66.68
Proposed Coverage Area (47.64 %)			45.38
Total Prop. Coverage Area (47.64 %)			45.38
Balance coverage area (22.36 %)			21.30
FAR CHECK			
Perm. FAR Area (1.800)			171.47
Total Perm. FAR area			171.47
Residential FAR			45.38
Proposed FAR Area			53.89
Total Proposed FAR Area			53.89
Consumed FAR (Factor)			0.57
Balance FAR Area			117.58
BUILT UP AREA CHECK			
Total Proposed BuiltUp Area			90.77
ARCHITECT (Regd)	RESHAN ALI		
ENGINEER (Regd)			
SUPERVISOR (Regd)			
OWNER (Regd)	1) SAJID NAJAM KHAN 2) ADIL NAJAM KHAN		
DEVELOPMENT AUTHORITY	LOCAL BODY		

Building :A (BUILDING)

Floor Name	Total Built Up Area (Sq.mt.)	Deductions (Area in Sq.mt.)	Proposed FAR Area (Sq.mt.)	Add Area In FAR (Sq.mt.)	Total FAR Area (Sq.mt.)	Total Consumed Additional FAR Area (Sq.mt.)	Tnmt (No.)
Ground Floor	45.39	36.88	0.00	8.51	8.51	8.51	00
First Floor	45.38	0.00	45.38	0.00	45.38	45.38	01
Terrace Floor	0.00	0.00	0.00	0.00	0.00	0.00	00
Total :	90.77	36.88	45.38	8.51	53.89	53.89	01

Buildingwise Floor FAR Details

Floor Name	Building Name		Total	
	Proposed Built Up Area (Sq.mt.)	Proposed FAR Area (Sq.mt.)	Total Proposed Built Up Area (Sq.mt.)	Total FAR Area (Sq.mt.)
Ground Floor	45.39	8.51	45.39	8.51
First Floor	45.38	45.38	45.38	45.38
Terrace Floor	0.00	0.00	0.00	0.00
Total :	90.77	53.89	90.77	53.89

FAR & Tenement Details (Table 4c-1)

Building	No. of Same Bldg	Total Built Up Area (Sq.mt.)	Deductions (Area in Sq.mt.)	Proposed FAR Area (Sq.mt.)	Add Area In FAR (Sq.mt.)	Total FAR Area (Sq.mt.)	Total Consumed Additional FAR Area (Sq.mt.)	Tnmt (No.)
A (BUILDING)	1	90.77	36.88	45.38	8.51	53.89	53.89	01
Grand Total :	1	90.77	36.88	45.38	8.51	53.89	53.89	01

Building USE/SUBUSE Details

Building Name	Building Use	Building SubUse	Building Structure
A (BUILDING)	Residential	Bungalow/ Dwelling / Non Apartment	Non-Highrise