

SITE PLAN

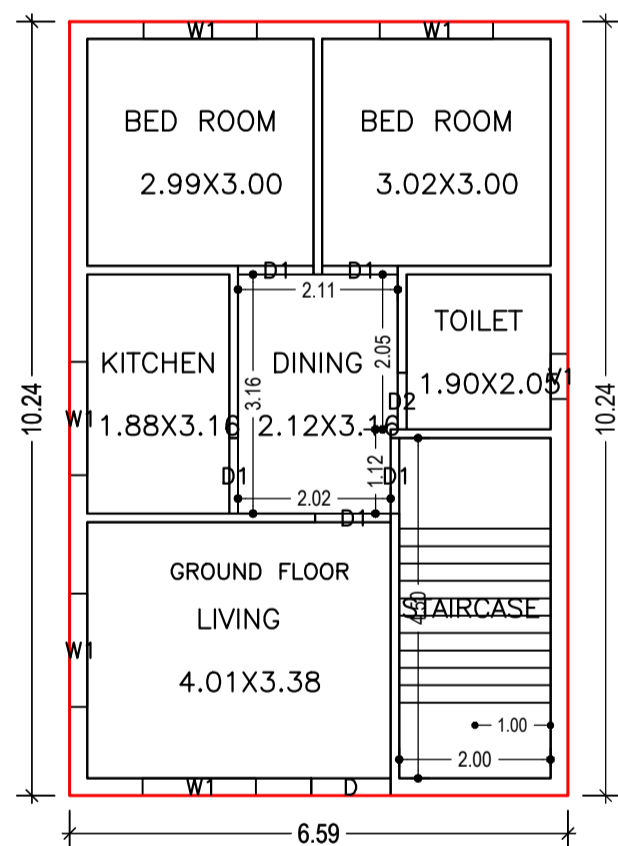

GROUND FLOOR PLAN (Proposed) (SCALE 1:100)

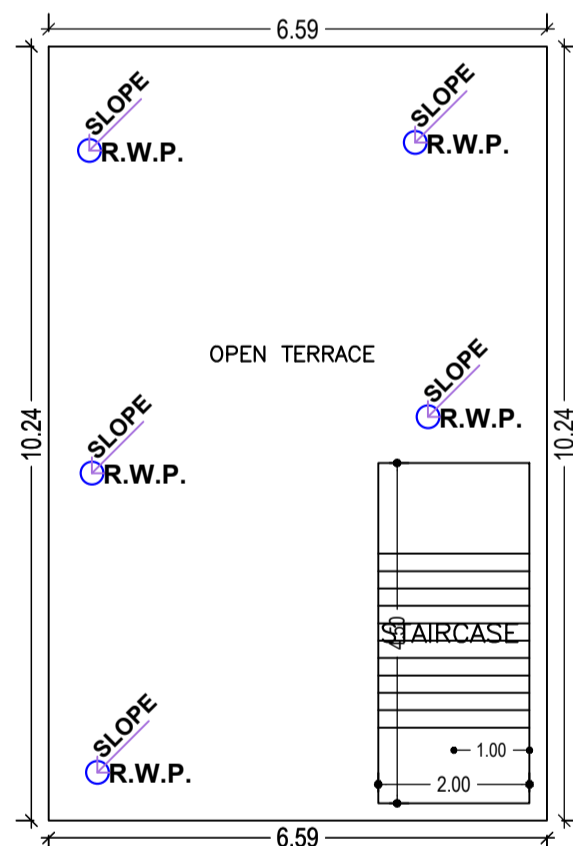

TERRACE FLOOR PLAN (SCALE 1:100)

Floor Name	Total Built Up Area (Sq.mt.)	Proposed FAR Area (Sq.mt.)	Total FAR Area (Sq.mt.)	Total Consumed Additional FAR Area (Sq.mt.)	Tnmt (No.)
Ground Floor	67.47	67.47	67.47	67.47	01
Terrace Floor	0.00	0.00	0.00	0.00	00
Total :	67.47	67.47	67.47	67.47	01
Total Number of Same Buildings	1				
Total :	67.47	67.47	67.47	67.47	01

SCHEDULE OF DOOR:

BUILDING NAME	NAME	LENGTH	HEIGHT	NOS
A (BUILDING)	D2	0.75	2.10	01
A (BUILDING)	D1	1.00	2.10	05
A (BUILDING)	D	1.05	2.10	01

SCHEDULE OF WINDOW/VENTILATION:

BUILDING NAME	NAME	LENGTH	HEIGHT	NOS
A (BUILDING)	V1	0.60	1.20	01
A (BUILDING)	W1	1.50	1.20	05

UnitBUA Table for Building :A (BUILDING)

FLOOR	Name	UnitBUA Type	UnitBUA Area	Carpet Area	No. of Rooms	No. of Tenement
GROUND FLOOR	FLOOR	FLAT	67.47	57.97	6	1
Total:	-	-	67.47	57.97	6	1

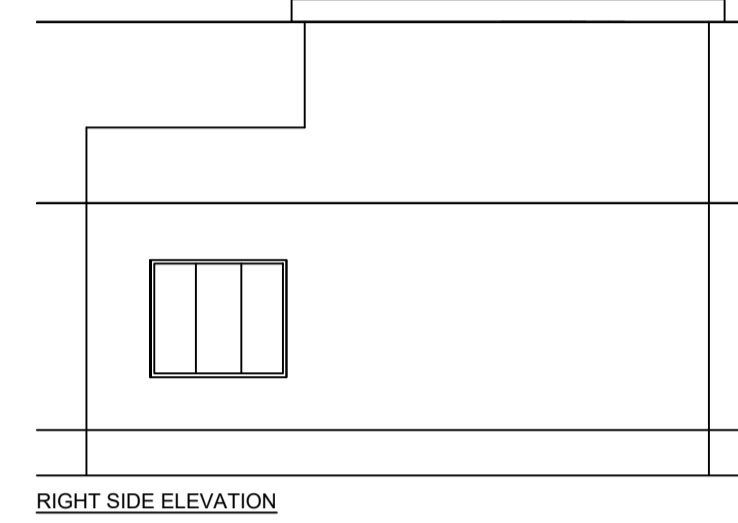
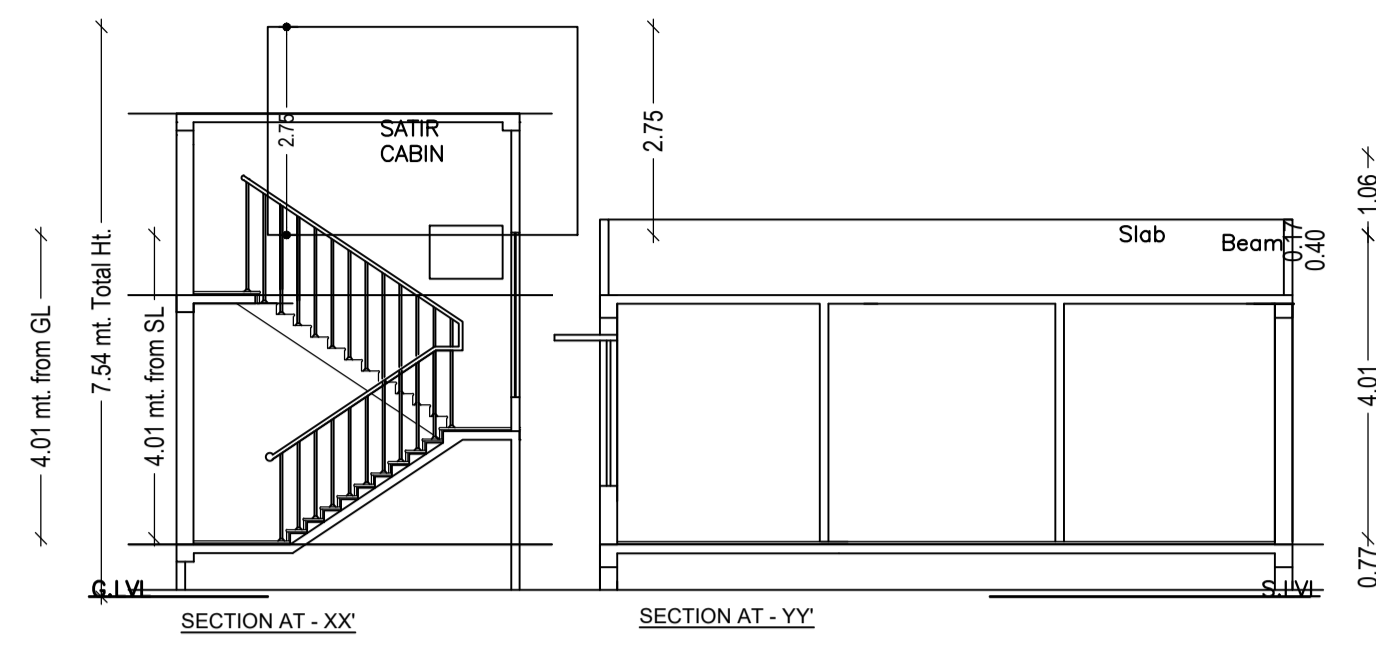

RIGHT SIDE ELEVATION

FAR & Tenement Details (Table 4c-1)

Building	No. of Same Bldg	Total Built Up Area (Sq.mt.)	Proposed FAR Area (Sq.mt.)	Total FAR Area (Sq.mt.)	Total Consumed Additional FAR Area (Sq.mt.)	Tnmt (No.)
A (BUILDING)	1	67.47	67.47	67.47	67.47	01
Grand Total :	1	67.47	67.47	67.47	67.47	01

Proposal Basic Information

Proposal File No.	GNPC/IBP/0067/W04/2023
Owner Name	SHRI RAVI SHANKAR DWIVEDI
Khata No	66
Plot No	324
Village Name	Sonpurwa
Use	Residential
SubUse	Bungalow/ Dwelling / Non Apartment

AREA STATEMENT GARHWA NAGAR PARISHAD		VERSION NO. 1.0.66
PROJECT DETAIL:		VERSION DATE: 16/10/2020
Region: JHARKHAND URBAN LOCAL BODIES	Plot Use: Residential	
District: GARHWA	Plot SubUse: Bungalow/ Dwelling / Non Apartment	
Authority: GARHWA NAGAR PARISHAD	PlotNearbyReligiousStructure: NA	
Inward No: GNPC/IBP/0067/W04/2023	Plot/SubPlot No: 324	
Application Type: General Proposal	North: Plot No. - 324	
Project Type: Building Permission	South: Plot No. - 324	
Nature of Development: New	East: Road Width - 4	
Location of Development Area: Old Area	West: Plot No. - 324	
AREA OF PLOT (Minimum)	(A)	SQ.MT. 122.49
Deduction for NetPlot Area		
Surrender Free of Cost		1.90
Total		1.90
NET AREA OF PLOT(Gross Plot Area - Deduction from Gross Plot area)	(A-Deductions)	120.59
Deduction for Balance Plot Area(from Gross Plot Area)		
Surrender Free of Cost		1.90
Common Plot		19.56
Total		21.46
BALANCE AREA OF PLOT(Net Plot Area - Recreational/Amenity space)	(A-Deductions)	101.03
PLOT AREA FOR COVERAGE(Net Plot Area)	(A-Deductions)	120.59
Plot Area for FAR (Net Plot Area + RoadWidening Area)	(A-Deductions)	122.49
COVERAGE CHECK		
Permissible Coverage area (70.00 %)		84.41
Proposed Coverage Area (55.95 %)		67.47
Total Prop. Coverage Area (55.95 %)		67.47
Balance coverage area (14.05 %)		16.94
FAR CHECK		
Perm. FAR Area (1.500)		183.74
Total Perm. FAR area		183.74
Residential FAR		67.47
Proposed FAR Area		67.47
Total Proposed FAR Area		67.47
Consumed FAR (Factor)		0.55
Balance FAR Area		116.27
BUILT UP AREA CHECK		
Total Proposed BuiltUp Area		67.47
ARCHITECT (Regd)		KUMARI MEENAKSHI TIWARI
ENGINEER (Regd)		
SUPERVISOR (Regd)		
OWNER (Regd)		SHRI RAVI SHANKAR DWIVEDI
DEVELOPMENT AUTHORITY		LOCAL BODY

COLOR INDEX	
PLOT BOUNDARY	Black
ABUTTING ROAD	Green
PROPOSED CONSTRUCTION	Red
COMMON PLOT	Yellow
ROAD WIDENING AREA	Blue
EXISTING (To be retained)	Orange
EXISTING (To be demolished)	Light Blue

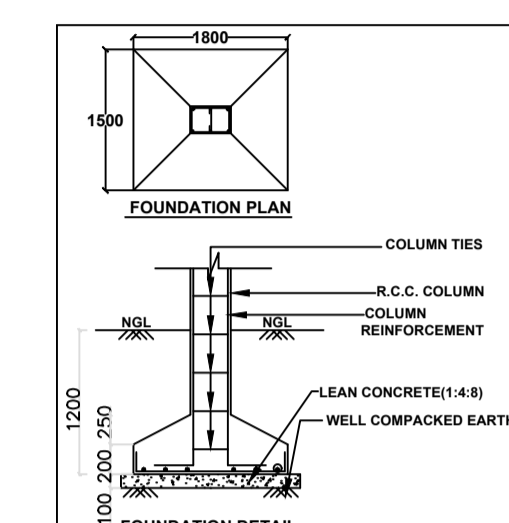

FOUNDATION PLAN

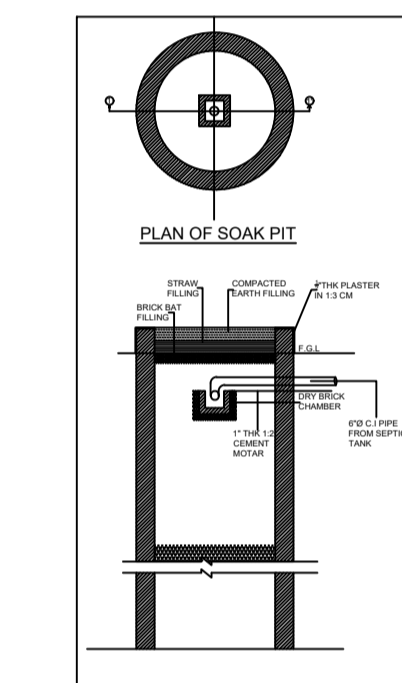

PLAN OF SOAK PIT

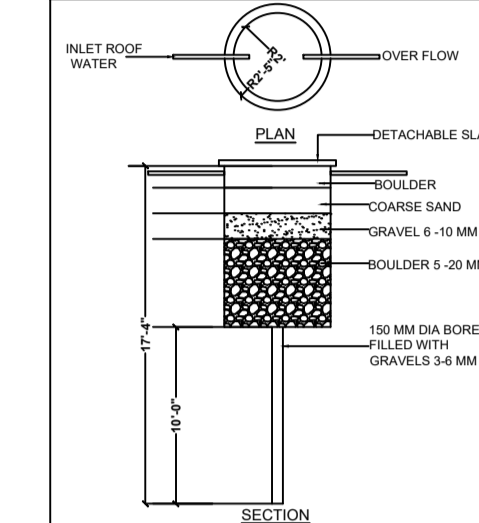

RAIN WATER HARVESTING

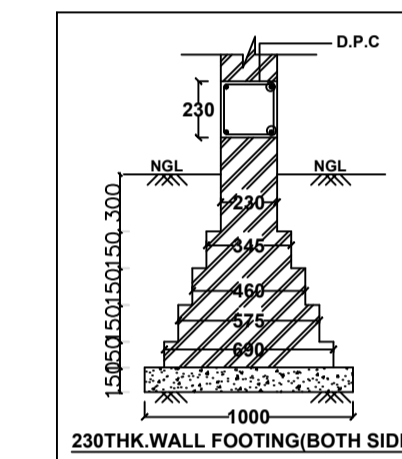

230THK WALL FOOTING(BOTH SIDE)

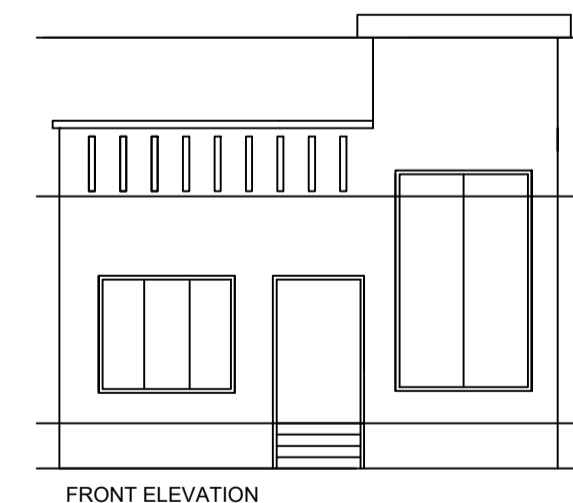

FRONT ELEVATION

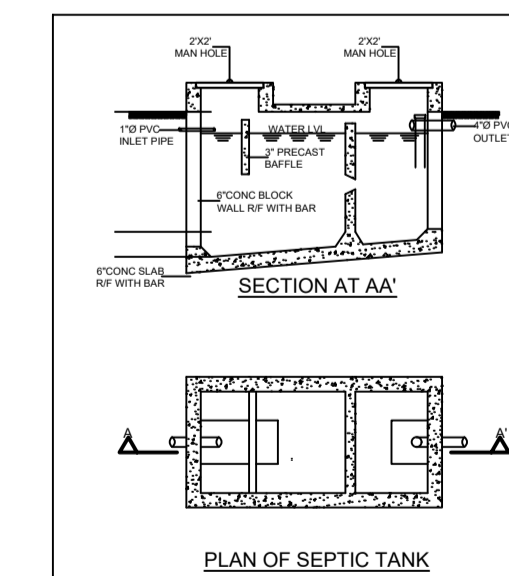

PLAN OF SEPTIC TANK

Buildingwise Floor FAR Details

Floor Name	Building Name A (BUILDING)		Total	
	Proposed Built Up Area (Sq.mt.)	Proposed FAR Area (Sq.mt.)	Total Proposed Built Up Area (Sq.mt.)	Total FAR Area (Sq.mt.)
Ground Floor	67.47	67.47	67.47	67.47
Terrace Floor	0.00	0.00	0.00	0.00
Total :	67.47	67.47	67.47	67.47

Building USE/SUBUSE Details

Building Name	Building Use	Building SubUse	Building Structure
A (BUILDING)	Residential	Bungalow/ Dwelling / Non Apartment	Non-Highrise

LTP NAME AND SIGNATURE	STRUCTURAL ENG'S NAME AND SIGNATURE	BUILDER NAME AND SIGNATURE	DIGITAL SIGNATURE
KUMARI MEENAKSHI TIWARI GNPC/ENG/006/2019			